

JOURNAL OF THE FORESTRY COMMISSION

No. 27 : 1958



PRINTED FOR DEPARTMENTAL USE



FORESTRY COMMISSION PUBLICATIONS
ISSUED IN 1958

General Reports

- | | |
|--|----------------|
| Annual Report of the Commissioners, 1957 | <i>5s. 6d.</i> |
| Report on Forest Research, 1957 | <i>9s. 6d.</i> |

Forest Records

- | | |
|---|----------------|
| No. 36. Provisional Yield Tables for Oak and Beech in Great Britain | <i>2s. 6d.</i> |
| No. 37. Alignment Charts for Form Height Tables for Determining Stand Volumes of Conifers, Oak, and Beech | <i>1s. 9d.</i> |
| No. 38. Design of Poplar Experiments | <i>2s. 6d.</i> |

Leaflets

- | | |
|--|----------------|
| No. 41. The Crested Tit | <i>1s.</i> |
| No. 42. Woodpeckers in Woodlands | <i>1s.</i> |
| No. 43. Keithia Disease of Thuja Plicata | <i>1s. 3d.</i> |
| No. 44. Voles and Field Mice | <i>1s.</i> |

Unpriced Publications for Circulation within the Commission:

Technical Notes

- | | |
|--|--|
| No. 5. Preparation and Maintenance of Efficient Fire Lines | |
| No. 6. The Roe Deer | |

JOURNAL OF
THE FORESTRY
COMMISSION

No. 27 : 1958



PRINTED FOR
DEPARTMENTAL CIRCULATION
WITHIN THE FORESTRY COMMISSION
25 SAVILE ROW
LONDON, W.1

EDITING COMMITTEE

SIR HENRY BERESFORD-PEIRSE, Bt., *Chairman*
JAMES MACDONALD
D. HEALEY
H. L. EDLIN, *Editor*

	<i>Page</i>
First Aid in Agriculture. MIN. OF AGRICULTURE, FISHERIES AND FOOD .	110
Safety Hints for Circular Saws. MIN. OF LABOUR AND NATIONAL SERVICE	113
Home Grown Softwood in London Docks. J. R. AARON	115
Divider as a Measuring Device in the Field in Forestry. V. BLANKENBURGS	118
Economics in Forestry. A. J. GRAYSON	119
Working Plan for Tentsmuir, Fife. D. A. WOODBURN	125
Measurement of Periodic Increment of Young Conifer Trees. J. L. G. HORNE	129
Bibliography on Windblow. G. D. KITCHINGMAN	132
Bibliography of Effect of Sea Spray on Trees and Seaside Tree Planting. G. D. KITCHINGMAN	134
Telling the Forestry Story. D. HEALEY	138
Let Us See it in Print. H. C. CRAWFORD	142
List of Finds from Staple Howe, Scardale Forest, sent to the British Museum. T. C. H. BREWSTER	144
Fire Tower at Emery Down, New Forest. R. H. PACKWOODD	145
Postscript to the Scottish Woodlands Census, 1947-49. A. M. MACKENZIE	146
Christmas Tree Cartoon. THELWELL of the " <i>News Chronicle</i> "	147
Forestry Commission Staff List	148
Photographs	<i>Central Inset</i>

EDITORIAL

The Commissioners

There was one change in the composition of the Forestry Commission during the past year, namely the appointment of Major F. W. Strang Steel as a Forestry Commissioner. Many readers will recall the outstanding services given to forestry by Major Strang Steel's father, Sir Samuel Strang Steel, Bt., of Philiphaugh, Selkirk, who was a Commissioner from 1933 to 1949, and it is in this connection that the announcement of his son's appointment makes singularly pleasant news.

Major Strang Steel, who resides in the same Scottish shire as his father, is a member of the Council of the Royal Scottish Forestry Society, and a member of the Royal Forestry Society of England and Wales, and also of the Society of Foresters of Great Britain.

The Commission at the end of the year was constituted as follows:

The Earl of Radnor, K.C.V.O. *Chairman*
 Major D. C. Bowser, O.B.E.
 Lt. Col. Sir Richard Cotterell, Bt., J.P.
 Mr. A. P. F. Hamilton, C.I.E., O.B.E., M.C.
 Mr. Lloyd O. Owen, J.P.
 Major Sir John Stirling, K.T., M.B.E.
 Mr. W. H. Vaughan, C.B.E., J.P.
 Mr. Robert Taylor, J.P.
 Mr. Edward Bryan Latham
 Major F. W. Strang Steel
 Mr. H. A. Turner, *Secretary*

Statement Concerning Forestry Policy

The following statement was made by Mr. John Hare, Minister of Agriculture, Fisheries and Food, in the House of Commons on 24th July:

"With your permission, Mr. Deputy-Speaker, and that of the House I should like to make a statement about forestry policy.

This has been reviewed by the Government in accordance with the announcement made in October, 1957. In the light of current conditions—strategic, economic, agricultural and social—they have reached the following conclusions.

The planting programmes of the Forestry Commission should be fixed for periods of ten years at a time. For the five-year period 1959 to 1963, the programme will be about 300,000 acres, which allows for some increase over the present annual rate of planting. For the period 1964 to 1968, the planting programme will be reduced to about 235,000 acres, when the Forestry Commission's existing plantations will begin to come into full production.

The size of the subsequent programmes should be reviewed in five years' time in the light of the national needs. In deciding where planting shall take place, special attention will be paid to the upland areas, particularly in Scotland and Wales, where expansion of forestry would provide needed diversification of employment and important social benefits.

The Government propose to continue their support to private woodland owners, particularly through the dedication scheme. The present maintenance grant of 5s. 6d. per acre will be replaced by a management grant of 18s. per

acre on the first 100 acres, 12s. per acre on the next 100 acres and 7s. per acre on the remainder. This will substantially increase the value of the grants, particularly on the smaller woodlands.

Secondly, the planting grant will be continued, but for approved woodlands it will be raised from one-half to the full rate per acre. These increased grants are contingent on the formation of an effective woodland owners' association, as recommended by the Watson Committee.

Thirdly, the grants for thinning and poplar planting will be terminated. The new structure of grants will be reviewed in five years' time. In reviewing, in future years, the level of grants, consideration will be given not only to trends in costs, but also to trends in receipts for private woodlands as a whole. As production from private woods taken as a whole—and thus the income of private owners as a body—rises, the level of assistance needed by way of planting and management grants will fall. Eventually—in say, twenty to thirty years' time—it should become nominal.

The system of felling licences will be continued. In present circumstances, it does not seem necessary to continue to fix a quota for the total annual felling, but the licensing system will be continued though with some relaxations. A Statutory Instrument will be made so that fellings in dedicated woodlands will no longer require a licence.

In addition, licences will, in general, be freely granted for other fellings subject to the existing arrangements for consultation with planning authorities. In order, however, to provide against the undesirable exploitation of woodland areas the licences will normally have a condition attached requiring restocking. And licences for thinning or selective felling will not be granted where they would, in effect, permit exploitation without restocking.

The Government recognise the importance of the forestry industry of an efficient home-grown timber trade. They believe that the measures just announced will be welcomed by the trade as well as by woodland owners, and will help both to plan ahead with confidence."

Promotions and Transfers

The following changes among senior members of the staff took place during the year.

Mr. George Ryle was transferred from the post of Director, Wales, to that of Director, England.

Mr. James Thom was promoted from the post of Conservator in Director, Scotland's office, to that of Director, Wales.

Mr. H. A. Maxwell, was promoted from Divisional Officer, West Scotland, to Conservator in the office of Director, Scotland.

Mr. G. Forrest, formerly a Divisional Officer in Director, Scotland's office, was promoted to Conservator and transferred to the staff of Director, Wales, to take charge of acquisitions and estate work.

Mr. S. M. Petrie, a Divisional Officer formerly stationed in North-East England, was transferred to East Scotland, and stationed at Aberdeen.

Mr. A. W. Arends, who is engaged on estate work in North Wales, was promoted from District Officer to Divisional Officer, with headquarters at Shrewsbury. Mr. W. T. Smith, a forest officer in North-East England, was promoted from District Officer to Divisional Officer, and is now stationed at Hexham.

Mr. P. A. Innes, formerly in the West Scotland Conservancy, was promoted to Divisional Officer and transferred to the office of Director, Scotland for acquisitions duties. Mr. E. J. M. Davies, formerly in North Wales, was promoted to Divisional Officer, West Scotland.

Mr. J. H. James has been promoted from Education Officer at Gwydyr School to Chief Education Officer, and is stationed in London.

Mr. A. H. Palmer has moved from the post of Chief Clerk in the office of Director, Scotland, to that of Chief Clerk in the English Directorate. Mr. T. H. McGeorge, formerly at Aberystwyth, was promoted to Senior Chief Executive Officer, and appointed Chief Clerk to the Scottish Directorate.

Mr. George Taylor, formerly at Headquarters, was promoted to Chief Executive Officer, and appointed Chief Clerk in the office of Director, Wales.

Mr. E. C. Harper, a Higher Executive Officer at Headquarters, was transferred to the post of Chief Clerk of the Education Branch.

Retirements and Departures

Mr. O. J. Sangar, the Director of Forestry for England, retired to live in Cornwall in November, 1958. He joined the Forestry Commission on its inception on 29th November, 1919. Previously he had served with the Interim Forestry Authority which he joined in May, 1919, on demobilisation, so that with service in British Columbia, before the 1914-1918 war, he had worked for well over forty years in forestry.

He was appointed Director, England, in 1946 and had in his charge over half a million acres of land of which some 400,000 acres are woodlands. As Director he was also closely associated with private woodlands throughout the country.

Mr. Sangar became a Commander of the Order of the British Empire (C.B.E.) in 1951 in recognition of his services to forestry. He served forestry abroad, as well as at home, and in 1947 he was delegate to the F.A.O. European Commission for Forestry and Forest Products, and subsequently its Chairman from 1948 to 1952.

Major General H. P. W. Hutson, C.B., O.B.E., D.S.O., M.C., the Commission's Chief Engineer since November, 1946 retired in March, 1958. Engineering activities expanded during the period, and General Hutson was responsible for the construction of about 3,000 miles of forest roads, oft-times in difficult terrain, and also for the establishment of the repair depots of Lightmoor, in the Forest of Dean, and Blair Atholl in Scotland.

Before joining the Commission General Hutson served as a professional soldier for thirty-three years. He is well known, in this country and abroad, as an ornithologist and is a past-Chairman of the British Trust for Ornithology.

Mr. R. H. Packwood, O.B.E., M.I.C.E., M.N.Z.I.E., who joined the Commission in March, 1950, had been successively Directorate Engineer, Scotland; Directorate Engineer, England; and Deputy Chief Engineer. Since the retirement of General Hutson, he had also carried out the duties of Commission Chief Engineer. He has accepted the post of Consulting Engineer to

the Department of Lands, Forestry Division, Government of Eire, and will take up his new duties in April, 1959, being based on Dublin.

Mr. R. G. Broadwood retired in October, 1958 after thirty-five years of forestry with the Commission. Mr. Broadwood studied at Edinburgh University intending to take up a medical career. But his studies were interrupted by the outbreak of the 1914-1918 war in which, while serving as a Commissioned Officer in the Royal Regiment of Artillery, he was seriously wounded and gained the award of the Military Cross. On his return to civil life he turned to forestry and, having obtained his degree at Edinburgh University, he entered the Indian Forest Service as a Forest Officer and took up the management of Himalayan cedar forests. He joined the Commission in 1924, beginning his service at Tintern. He served in North Wales and was in charge of the first planting at Dovey, now a "showpiece" among Welsh forests. Later, Mr. Broadwood was in charge of the Forester Training School at Parkend, in the Forest of Dean.

Returning to field duties, he had jurisdiction over an area which covered Cornwall, Devon and Somerset, with headquarters at Exeter. Afterwards, he moved to South Wales where his last appointment was Conservator. Subsequently, at Headquarters, London, he took over duties which included the preparation of the Commissioners' Annual Reports. He was also concerned with the organisation of publications, and with arranging tours for overseas Forest Officers and others. After the second world war Mr. Broadwood revived this Journal and served as its Editor from 1948 to 1954.

Having served thirty-two years with the Commission, Mr. C. E. L. Fairchild, Divisional Officer, North Wales Conservancy, has retired. Mr. Fairchild graduated from Bangor University, joined the Commission as a District Officer in 1926 and transferred during that year to North Wales. In 1928 he became the first Estate Officer at Shrewsbury, and he has had charge of estate work in North Wales continuously for almost thirty years.

He was, too, a golfer of outstanding ability, obtaining numerous golfing honours, and at one time was Welsh Amateur Champion.

Another outstanding career is brought to notice by the retirement of Mr. E. S. J. Hinds from the post of Chief Clerk at the Directorate for England. Mr. Hinds joined the Office of Woods as a Boy Clerk in December, 1913. He saw service with the Royal Naval Air Service and the Royal Air Force from September, 1916 to February, 1919. On his return to civilian life he was posted to the Forestry Branch of the Office of Woods. Later, in 1924, came the official transfer of the Crown Woods, together with most of the staff, including Mr. Hinds, to the Forestry Commission. In June, 1947 he was appointed Chief Clerk in Director England's Office. He has served under five Assistant Commissioners or Directors, namely Sir Hugh Murray, Mr. H. A. Pritchard, Sir William Taylor, Mr. A. P. Long and Mr. O. J. Sangar.

Mr. Hinds continues to serve at Headquarters and has a special concern for the English Forest Tree Seed Association. In 1949 he was appointed M.B.E. and in 1954 was promoted O.B.E.

Mr. J. G. S. Gillingham, Chief Clerk, Education Branch has retired from the Commission after a career in public service which began as long ago as

1915. The first world war claimed him and he served with the Royal Horse Artillery and somewhere in "Mesopotamia" he was awarded the Military Medal. He came to the Commission in 1927 and for a period during and after the 1939-1945 war was seconded to the Timber Supply Department, and part of this time was served with the Control Commission in Germany. For a number of years he was Chief Clerk in the Education Branch, and he has now taken a post at the County Court, Brighton.

Also among the retirements listed chronologically are the names of Mr. Frederick Matthews (Messenger), Mrs. M. G. Ward (Personal Assistant to the Deputy Director-General), and Mrs. A. G. D. Pratt (Telephonist).

"Freddie" Matthews was a messenger at Headquarters for ten years; he was 72 years young, spritely and forthright.

Mrs. Ward was one of the original members of the staff of the Commission which, as Miss Alexander, she joined on its inception in 1919, having served previously for a couple of years with the Interim Forest Authority. In 1921 she left to be married and in 1933, being widowed, she rejoined the Commission at the office of old Division 4 (South-East England). Later she came to Headquarters and at the time of her retirement she was Personal Assistant to the Deputy Director-General. Mrs. Ward has three children and four grandchildren, and plans to go to South Africa in 1959 to visit her son.

Mrs. Pratt, Telephonist at Headquarters for ten years, has also left the Commission and, on re-marriage, is to live at Plymouth. She will be remembered for her unflinching courtesy and seemingly inexhaustible patience by everyone at Savile Row, and throughout the Commission.

Obituary

We record with regret the passing of the following serving officers:—

Mr. F. Cownie, Conservator at the Office of Director, Wales.

Mr. I. Robertson, Chief Education Officer.

Mr. D. N. Williams, District Officer in the South-West England Conservancy.

Machinery Exhibition at Blackbushe Aerodrome, Hampshire

This two-day exhibition was the first of its kind to be arranged by the Commission and the biggest ever to be held in the country. There were more than seventy exhibitors and the display was admirably staged by the Commission's Machinery Research Officer, Col. R. G. Shaw, assisted by Mr. John Harper and staff, after many weeks of preparatory work. The exhibition opened in brilliant sunshine and visitors were numerous.

Highlights of the exhibition included demonstrations by spectacular scrub clearing machines which literally ate up heather and small birch trees; the extraction of timber by overhead cable way; and the spraying of woodland with insecticide from a helicopter. It is hoped that the bringing together of so much equipment on a single site will encourage an even greater increase in the rate of private planting.

New Suspension Bridge

A 200 ft. suspension bridge over the River Wye was declared open by Sir Richard Cotterell, Chairman of the Dean National Forest Park Committee. It is designed to carry 40 people dispersed over it, or 30 concentrated over the

middle section, and is intended mainly for the use of Commission employees. Mr. R. H. Packwood, at that time Deputy Chief Engineer, is the designer, and the span of the bridge is believed to be half as long again as any suspension bridge previously constructed by the Commission.

New School of the Village of Ae

Ae is a forest village about ten miles from Dumfries, in south Scotland, and the opening of the new school is an historical landmark there. The school comprises three class rooms and was built in a surprisingly short space of time, for the plans received the approval of the education Authority as recently as March, 1958. It cost £21,000 and most, if not all, of the scholars will be the children of Commission employees. The village itself has grown with equal rapidity, for the ceremony to mark the commencement of the building of Ae Village took place in 1947. Since 1927, when the Commission started the Forest of Ae, local employment has risen from 16 to 100; by 1980 it is anticipated that some 350 men will be gaining a livelihood in the area. There are now 58 houses comprising the village and providing accommodation for 160 adults; of the 90 children (November, 1958), 50 are of school age.

Opening a New Village Hall

A Red Letter day at Dalavich Village, Inverliever Forest, West Scotland, was the opening of a new village hall. Hitherto it had been the lecture room of the Glentress Forester Training School which was closed down to give place to the school at Faskally. The new hall was declared open by Mr. J. E. James, Conservator for West Scotland.

There is a fine stage, complete with footlights, and a Dramatic Society is in the making. Already in being are a Scottish Country Dance Club, a Small-bore Rifle Club, and a Modern Dance Club. Community life will be further enriched by regular concerts and dances.

Bronze Medal for the Commission Sulky

Following a demonstration in a competition for forest machinery, organized by the Royal Agricultural Society of England and held on a site near Oxford, a self-propelled Sulky entered by the Commission was awarded the Society's bronze medal. Acting as a mechanical horse, the Sulky has a carrying capacity of loads up to half a ton; forward and reverse gears allow the machine, steered by the operator, to travel in either direction at walking pace. A centrifugal clutch on the 280 c.c. engine provides very sensitive control. There is a photograph of this Sulky in the Central Inset, Plate No. 22.

Forest Retreat for Boys' Club

A 100-year-old farmhouse in a remote part of Beddgelert Forest near Snowdon has been leased by the Commission to Ludwick Boys' Club, Welwyn Garden City. The farmhouse has been renovated by twenty-five young club members, helped by four adults. The members plan to make regular summer visits for climbing holidays.

Fire in Satterthwaite Village

The auld enemy, fire, struck again when lightning hit the gable of one of the Commission's houses at Satterthwaite, Grizedale Forest, in North-West England Conservancy. The house was gutted, with great personal loss of property to the occupants and causing also much damage to the house next door. Under the auspices of the Local Council a fund was opened to aid the unfortunate occupants.

Penalties for Moorburning Out of Season

A regulation contained in Statutes 4 and 5, William and Mary, C. 23, warns that “. . . to burn on any waste, between Candlemas (February 2nd) and Midsummer, any grig, ling, heath or furze, goss or fern, is punishable with whipping and confinement in the house of correction”.

William and Mary commenced to reign in 1689 but there would appear to be little change in the fire hazard, and the provisions of the Heath and Grass Burning (England and Wales) Regulations 1949, among other things, provide “. . . that between the 31st March and 1st November in any year, no person shall burn heather or grass except in accordance with a licence issued by the Minister of Agriculture, and *at all times* notice (as specified in the Regulations) shall be given to adjoining occupiers of a proposal to carry out burning”. Inside the conventions of modern times penalties under these 1949 Regulations are unlikely to be as drastic as those cited above. There is also a slight difference in the length of the closed seasons as laid down in the earlier and later regulations, and for that reason it might be as well to watch out because, although all the edicts of William and Mary no longer apply, this particular one may still hold good. Better, however, to remember that, at most seasons of the year, dry grasses, heather and gorse will burn fiercely; fires easily get out of control, spread and ignite plantations, which is why fires lighted to burn rubbish or to improve grazing should not be started on a windy day, nor without sufficient persons in attendance to keep proper control. In passing, grig, mentioned in the opening paragraph above, is heather and, of course, goss is gorse.

Civil Service Lifeboats

The Commission's first collection for the Civil Service Lifeboat Fund realised £373. This is a magnificent response which must be highly gratifying to organiser, donors and the Royal National Lifeboat Institution. It is noteworthy that £100 was collected in the North Wales Conservancy alone.

The organiser, Mr. L. C. Grinter of Headquarters, and all the collectors in the various offices, are to be congratulated.

Meanwhile the lifeboats and crews still put out to sea, and it is a privilege to be able to continue to support them and their life-saving efforts. And we are reminded that these lifeboats, even today, are made of wood, and English oak is still chosen for the stem and the stern. And hearts of oak (need it be said?) are the boats' crews who man these Civil Service lifeboats in all weathers.

The Civil Service Benevolent Fund

Every year the Civil Service Benevolent Fund spends about £100,000, helping by weekly allowances nearly two thousand Civil Service families in financial distress following death or sickness, and helping many hundreds of serving and retired civil servants who have met with unforeseen misfortune. Members of the Commission's staff have received assistance, ranging from a lump sum grant to meet urgent need immediately following an officer's death, to a weekly and continuing allowance as the result of distress arising from premature retirement or death before adequate dependent's pension entitlement has been achieved.

While it can be seen from the above figures that the average amount of help per family is not very large, it makes a great difference to families living on the borderline of want.

Apart from direct financial help, the Fund provides some 80 places for retired Civil Servants and dependent parents of Civil Servants in need of care

and attention. The Fund has two seaside homes of its own and has places in seven other homes in different parts of the country. The Fund also subscribes to eight boarding schools where fatherless children can be provided with an excellent education.

The Fund needs a much bigger income so that it can give more help in many cases, and extend even more widely the scope of its activities. Instead of its income steadily increasing to meet the ever-increasing demands upon it, unfortunately it has remained stationary for the past few years. Indeed, the income from deeds of covenant has dropped appreciably (from £11,009 in 1955 to £8,743 in 1957), mainly due to deaths and retirements.

The deed of covenant procedure enables the Fund to recover income tax deducted on gross incomes from which contributions are derived. Thus, if tax is paid at the full standard rate, a contribution to the Fund of, say, 3d. per week (13/- per annum) authorised on a deed operating for a period of seven years, enables the Fund to recover an additional 9s. 8d. per annum from the Inland Revenue at no additional cost to the contributor.

The Forestry Commission Whitley Council appeals to every non-industrial member of the staff to:—

- (a) become a contributor by signing a simple form authorising regular deductions of a few pence each week from pay;
- (b) in the case of existing contributors to consider an increase in their present contribution; and
- (c) enter into a deed of covenant which in most cases can be done without additional cost to the contributor.

Copies of the necessary forms can be obtained on application to Mr. H. P. Wilbraham, Savile Row.

Staff Suggestions Scheme

The Staff Suggestions Scheme is limited to suggestions from the non-industrial staff (Office Staff, and Professional and Technical Staff down to and including Foremen). A similar but separate arrangement—the Monetary Awards Scheme—caters for the Commission's industrial employees.

It is the essence of the Scheme that awards should not be made for suggestions which ought to arise in the course of the work of any normally efficient officer. Suggestions for the improvement of work in an officer's own section or branch should be made to his senior officer in the usual way, and, so far as any "reward" is deserved, it will come in the form of enhanced reputation for efficiency: only the outstanding suggestion, in a field which is not part of the originator's usual duty, qualifies for an award.

Since the Scheme was introduced, nearly 500 suggestions have been submitted and about 100 have been accepted. The latter have covered such subjects as improvements to equipment, publicity, accounting and office procedure, etc., and have attracted awards of up to £25.

The suggestions which have been rejected fall broadly under the following headings:—

- (i) Those of insignificant value.
- (ii) Those clearly not the result of original thought on the part of the originator, e.g. because they are common practice in the Commission or elsewhere, or are only very minor improvements on existing methods.
- (iii) Those too closely related to the originator's normal work.

Officers are invited to put forward any suggestions for consideration under the Scheme to the Secretary of the Suggestions Committee at 25, Savile Row, London, W.1. Each Suggestion will be given an identification number and acknowledged. Only the grade and location of the originator, not his or her name, will be made available to the Committee until a decision is taken. Thereafter, only the names of those whose suggestions are accepted will be revealed.

Timber and Atomic Energy

Logs being loaded on to a lorry would, to a forester, seem a fairly commonplace operation but the final destination of the load can be a matter of interest, and a recent picture in the Newcastle-on-Tyne "*Evening Chronicle*" showed just where that interest lay. The logs that were being swung aboard the lorry were Douglas fir cut from the Commission's plantation at Dodd Fell, near Keswick, and they will be used to line the cooling towers of the new atomic energy plant at Annan, on the Scottish side of the Solway Firth.

Home-Grown Telephone and Transmission Poles

(Contributed by Sir Eric Savill, K.C.V.O., C.B.E., M.C.)

It may be of interest to your readers to study a report from the Department of Scientific and Industrial Research, Forest Products Research Laboratory at Princes Risborough, on a test carried out of Scots pine poles grown on the Windsor Estate of the Commissioners of Crown Lands. The report reads as follows:

STRENGTH TESTS ON SCOTS PINE POLES

At the request of the Crown Estate Office, the Great Park, Windsor, tests were undertaken on transmission poles grown on the Estate in order to provide basic strength data.

Twelve freshly felled poles were supplied for the tests.

When received at the laboratory the poles were in a green condition and had a moisture content of about 100 per cent. Each pole was cut to a length of 20 ft. from the butt and tested to destruction in accordance with standard procedure of the laboratory. The span for the test was 18 ft. 6 in. with a point of application of the load 4 ft. up from the butt support point of the pole.

The results of the tests were as follows:

Pole No.	Diameter		Maximum Bending Strength lb./sq. in.	Modulus of Elasticity or Stiffness 1,000 lb./sq. in.	Weight at 30 per cent moisture content lb./cu. ft.
	Top in.	Butt in.			
1	6.0	7.2	8,820	1,728	46
2	5.9	7.2	8,120	1,705	43
3	5.8	7.2	8,620	2,199	45
4	6.0	7.8	8,380	1,151	41
5	6.1	7.4	9,150	1,953	45
6	6.0	7.2	10,540	2,602	49
7	5.0	6.2	9,210	1,954	48
8	5.0	6.4	8,540	2,266	47
9	5.7	7.3	9,650	1,840	46
10	5.3	7.2	9,800	2,326	52
11	5.5	7.2	9,020	2,177	46
12	5.7	7.2	8,490	1,483	39
Av.	5.7	7.1	9,030	1,949	46

The type of failure was: mainly compression with ultimate tension.

The high degree of compression failure under test indicated toughness in the poles which also contained a high percentage of sapwood. Growth rate was good and with a range of about 8—16 rings per inch were comparable with imported poles of similar size.

Compared with imported European redwood poles, the average values obtained for bending strength were about 10 per cent greater, and for stiffness about 20 per cent greater.

It will be seen from this test that it is possible to grow in this country Scots pine poles suitable both for the Post Office and for the Central Electricity Authority, and which are at least equal in strength to imported redwood European poles—redwood being the trade name for Scots pine.

Many of your readers will recall the *Report of the Committee on Marketing of Woodland Produce*, 1956. Section 47 of this report indicates that the post-war consumption of the Post Office has been just over 100,000 poles per annum, of which 87 per cent are imported; that the purchases of the Electricity Boards had been rising annually, from 150,000 poles in 1950 to over 240,000 in 1955.

The report adds that for the past few years practically all the poles purchased by Electricity Boards in England and Wales have been imported, while in Scotland 3 per cent of home-grown poles were used.

The Crown Estate Commissioners have for many years sold poles to the Post Office for telephone lines and in 1958, for the first time, negotiated a sale of Scots pine poles to one of the Electricity Boards, in sizes ranging from extra lights to stouts.

No doubt there are many other woodland owners who could take advantage of this expanding market.

Preserving Conifer Specimens

The following note is contributed by Sir Edward Salisbury, formerly Director of the Royal Botanic Gardens at Kew:

The usual method of treating specimens with needle-shaped leaves, which tend to fall off in drying, such as those of heaths and conifers, is to immerse the specimens for a few seconds in boiling water before placing them in the drying press.

Trees in Essex

We have received from the Clerk to the County Council of Essex, County Hall, Chelmsford, a copy of an interesting booklet entitled: *Trees—A Report on Tree Preservation, Afforestation and Landscape Conservation in the County of Essex*. Little has been published on the place of trees and woods in this well-farmed region of Britain. There are now two Commission forests in Essex: Honeywood Forest, which covers 685 acres of woodlands in the Halstead/Coggeshall area; and Walden forest, which lies roughly between Saffron Walden and the Cambridge border and whose component woodlands cover 719 acres. A further 456 acres of woodlands have also been acquired by the Commission but have not yet been allocated to any particular Commission forest; this latter area comprises woodlands as far apart as Harlow (Mark Hall Estate Wood), Tiptree (Pods Wood), Layer Marney (Layer Wood), Hatfield Forest and Navestock (Church-owned woods). This gives a present total of 1,860 acres. Operations in the two forests have so far been confined almost entirely to replanting areas which were clear-felled by their former owners prior to being taken over by the Commission. Over the past five years 260 acres have been replanted with something like three-quarters of a million trees.

Those interested in this Essex County Council booklet are advised to obtain a copy (free of charge) from County Hall, Chelmsford.

What's in a Name?

Many foresters have been puzzled by the name "Ursuline" applied to a peculiar strain of Corsican pine once widely planted, usually with disappointing results, by the Commission.

Some of us have searched the botanical textbooks in vain for any description of "*Pinus nigra* var. *ursulina*", while others have scoured their atlases for any district named "Ursuline".

Mr. J. M. B. Brown, who is making a special study of Corsican pine and has visited Corsica recently, has run to earth, so far as is possible, the origin of this curious term.

It first appears in a letter received at Headquarters on January 4th, 1926 addressed to "Monsieur Forestry Commission, London", and signed by "Grimaldi Ursuline", written from Sidossi de Calacuccia in Corsica. Evidently the writer followed the unusual, but by no means an uncommon, practice of putting the surname first. There were numerous seed merchants named Grimaldi, both in Corsica and Marseille.

Another letter, in similar handwriting, followed on 27th February, 1926, addressed to "Monsieur Office of Woods, 1, Whitehall, S.W." This time the signature ran "Ursuline Grimaldi", the address being as before.

Although the Christian name "Ursuline" is frequently used on the Continent for a girl, there would be nothing extraordinary in the name, derived from Saint Ursula, being borne by a man in Corsica.

Mr. Brown's enquiries in Corsica revealed several people named Grimaldi who are still dealing in Corsican pine seed. No seed merchant named "Ursuline" was known to the Conservator of Forest and his staff. It thus appears that "Ursuline Grimaldi" (whether man or woman) was a collector of cones who strayed widely from the Corsican pine stands that were the usual source of supply for the Forestry Commission.

Mr. Brown's enquiries indicate that the collecting ground of the Ursuline seed, known as "Pascio Mountain", lies in the vicinity Monte Cinto, the highest in Corsica, which stands about 6 miles north-west of Calacuccia. Unfortunately time did not permit of a visit, but he suggests that the woods there may merit investigation.

Two consignments of seed, amounting to 3,955 lb. in 1928 and 1,611 lb. in 1936, were officially recorded as coming from the Pascio Mountain locality, which may in addition have contributed to some other consignments from the Calacuccia merchants.

The Changing Forest Landscape

Seldom does the opportunity arise to compare a landscape before, and after, its afforestation. We are indebted to Mr. Valdemars Blankenburgs, a Surveyor at Kielder Forest, for the example that appears as Plates 1 and 2 in our photographic pages.

Sometime about 1920, a local photographer took a view of a "beauty spot" in the Lewisburn Valley. About thirty-five years later, Mr. Blankenburgs went to the same spot, pointed his camera the same way up the valley, and secured the corresponding view.

This pair of pictures, we believe, provides a fitting answer to those critics who maintain that afforestation with conifers can only harm a landscape. Norway spruce and Scots pine have replaced heather, bracken and oak scrub, while a fringe of birch, rowan and alder has been left between the road and the burn. The result, we maintain, is a finer view than before.

First Record of Christmas Tree

When was the Christmas tree first recorded in this country? John Stow, in his *Chronicle of London*, which was written in the time of the First Queen Elizabeth and of that King James sometimes known as the First of England and the Sixth of Scotland, speaks of a tree set up in 1444 in Cornhill in the City of London, at Christmas-time, decorated with evergreens, which was overthrown during a great storm. Maybe the tree got mention, not so much as being the first Christmas tree, but to record the great 'windblow' during which it was brought down.

In German and Scandinavian countries the fir as a Christmas tree is a very old tradition, but it was in Victorian times that the Norway spruce came into use as the familiar Christmas tree. Decorated with lighted candles, it was introduced at a children's party at Windsor Castle in 1841, doubtless by the Prince Consort.

There is now a flourishing home-grown Christmas tree market in this country, and Commission and private woodlands sales total may well exceed 1½ million young Christmas trees and thinnings annually.

Permits to import Christmas trees are given only to public authorities in port areas. Most famous is the Norwegian tree set up in Trafalgar Square every Christmas. All these imported trees must be burnt when they are dismantled.

All the trees on sale, therefore, are home-grown so that, around the Festive Season, there are occasional difficulties due to unauthorised 'finding' and scrounging. We are indebted to the *News Chronicle* for permission to reproduce on page 147 the humorous cartoon by Thelwell of the man who brought one back.

Ideas are Needed and Invited for Show Exhibits

Many readers will know of the Commission's travelling show outfit, which Forester Wilkinson takes on tour every year to all the major Agricultural Shows in England, Scotland and Wales.

On these Show grounds the Commission's flag will be seen where its work is brought to the notice of the public by means of two sections: one, the outdoor Conservancy exhibits which usually cater for the woodland owners and their agents, and the other is an indoor affair sited, as a rule, in a pavilion or a marquee.

Besides selling the Commission's publications and distributing free literature, this covered section houses an important display intended particularly to have an appeal value to the general public. It tells a story that is simple, coherent and maybe dramatic, and movement is introduced by means of animated models, and it is, and must be, based on a theme which runs through the entire indoor exhibit.

Displays in recent years have been arranged under the titles: "Friends and Foes of the Forest", "The Prayer of the Tree" and for 1958 the title was "Popular Misconceptions about Forestry". The last named exhibit found so much favour that it will be largely repeated for 1959, but every future year a new approach is needed.

The current exhibition may serve as a guide as to what is wanted, always remembering there must be a theme running throughout. Visitors are asked if they are aware that most of the well-loved trees in our parks, gardens and woodlands are "exotics"; they are invited to name a few native conifers and, of these, photographs appear with descriptions. Illustrations and descriptions of alien conifers follow, without which it is explained Britain would have scarcely any home-grown softwoods.

The origin of native and exotic hardwoods is examined. It is pointed out that the tree is the largest and longest-lived organism in the world and a giant Californian sequoia is illustrated to make the point. Through this model sequoia runs a roadway along which miniature cars move. Some of the biggest trees in Britain are described, and by photographs and diagram are compared with Nelson's Column in Trafalgar Square, London.

Photographs in revolving drums and a display of timbers of different ages, and diagrams, set out to prove that with the passing of time conifer forests become beautiful. Reasons and explanations are given for the planting of more conifers than hardwoods, and as trees, like other crops, grow from seeds, the tremendous number of trees than can be grown from what may seem small quantities of seed is demonstrated. The wild life of the forests is also put into perspective.

Have our readers any ideas to offer for future displays, please? All will be given most careful consideration and the Principal Information Officer, Mr. D. Healey at Savile Row, London will be delighted to have them. No reward can be offered, except gratitude, but it is felt that colleagues may well have some brilliant ideas and may have something helpful to say in this publicity matter.

Work Study in Old Testament Times

Thus saith the Preacher:

"The quarry-worker and the wood-cutter must exercise caution in their work".

Ecclesiastes Chap. 10 v. 9.

"The wise woodman does not tire himself out, when sharpening his blade will ease his work".

Version by S. N. Sedgwick, M.A., from

A New Commentary on Holy Scripture
(S.P.C.K.)

"If the iron be blunt, and he do not whet the edge, then he must put to more strength: but wisdom is profitable to direct".

Ecclesiastes Chap. 10 v. 10, *Authorized Version*.

And another free translation:

"The workman who does not whet his tools must work with more strength".

Photography in the Service of the Nation

Mr. Tony Anderson, the Commission's Principal Photographer, deserves special mention for his share in: "Photography in the Service of the Nation", a unique exhibition organised by Kodak and displayed at Kodak House, Kingsway, London. This comprised a collection of photographs taken by Government photographers. Eleven examples of his work were selected.

Our Photographs

Many of our photographs are contributed by the authors of the respective articles, and their source is acknowledged on the plates. In addition, we express our gratitude to:

Mr. E. Dobbin, of Bellingham, Northumberland, for Plate 1; Mr. V. Blankenburgs of Kielder, for Plate 2; Mr. Arthur E. Murray for Plate 6; and Mr. Tony Anderson for Plate 22.



Fig. 1. Forest Fires—as seen by Macdonald of the *Weekly News*.

JOURNAL OF THE FORESTRY COMMISSION, No. 27, 1958

A VISIT TO CANADA

By Dr. MYLES CROOKE

Research Branch

The train from New York stopped at the Canadian border to allow the customs and immigration officials aboard. I moved out of the sleeper and started chatting to a Canadian—the first I had met on his side of the Atlantic—whilst the inspections were proceeding. After a few moment's conversation, during which he had told me that he had been in England in the army during the war and that he now worked for the Canadian National Railways, he said "Look, you're coming to Ottawa and I live there. Why don't you and the family come and stay at my home. My wife and I would be glad to welcome you there". This spontaneous offer of hospitality, unexpected as it was, proved to be typical of all the kindness we were to experience during our six month's tour in Canada, and generosity such as this was to make the coast-to-coast trip, travelling as we were with our year-old daughter, much easier and more pleasant for my wife and myself than it would otherwise have been.

My visit to Canada had been made possible by the award of a fellowship from the Nuffield Foundation and by the Commission's granting me leave of absence for the necessary period. I was going over to have a general look at the organisation and activities of the Forest Biology Division, the government department responsible for investigation of forest insect and disease problems. It should be made clear at the outset that this division is not a part of the Federal Forest Service, although of course it works in close co-operation with that service and also with the provincial forest departments as well as with the timber industry. This—to our minds—rather curious situation has arisen by the Forest Biology Division having evolved from the amalgamation in 1951 of two sections of the Science Service—the Forest Insect Investigations Unit of the Division of Entomology and the Forest Pathology Investigations Unit of the Division of Botany and Plant Pathology. The Department of Agriculture's Science Service is responsible for fundamental and applied research relating to the protection of agricultural plants and forest trees against damage by insects and diseases, including malnutrition. It is also concerned with animal nutrition and livestock insects and at the present time comprises five divisions—those of Bacteriology, Botany and Plant Pathology, Chemistry, Entomology, and Forest Biology.

The Forest Biology Division has a staff of some six hundred, including 170 research officers and 250 technicians, based on regional laboratories sited at strategic points throughout the country. The general pattern is to have fairly large centres for staff working on entomology and pathology complemented by a number of smaller laboratories, usually devoted to one or other of the disciplines, and of field stations which are manned only during the summer months. A great variety of problems are being studied, ranging from the deterioration of fire-killed timber to the genetics of the spruce budworm, from seedling diseases to pinhole borer attack, from the virus diseases of insects to fume damage to trees. In this article it is, of course, impossible to attempt to review all these activities but some of them were chosen for particular study because it was thought that Canadian knowledge and experience of them might provide general guidance for similar work in Britain. I give some brief notes on two of these subjects which may be of interest.

Firstly, the Forest Insect Survey which has as its main objectives the exploration of the Canadian forest insect fauna and the appraisal, and if possible, forecasting, of forest insect outbreaks. In the past most of its work has been of a purely qualitative nature. Forest insects were collected, usually by simple methods such as hand collecting or beating, and then reared, identified, and notes made on the parasitism of the sample. In infestation areas, maps were prepared showing the areas of heavy, medium, and light attack. This approach did much to build up background information on the fauna—in itself a formidable task in such huge forested areas—and to direct attention to losses caused by insect attack and to areas where control or rapid exploitation might be required. Nowadays the trend is towards producing more precise and quantitative data from permanent sample plots or individual trees, and from these to attempt to define population trends. It is, in fact, an approach that is closely similar to that followed in our own annual Pine Looper Moth survey. The general collections and rearings continue, but selected important species are given a “fuller treatment” by the surveyors, and efforts are being directed towards making the surveys more fully representative of the fauna than was the case in the past when defoliators were worked over much more intensively than were other groups. Considerable use is being made of sequential sampling methods, which in many cases reduce the amount of field work required and still give acceptably accurate results in terms of population density classes.

In an average year the forest insect survey makes about 25,000 separate collections. Most of these—somewhere about 90 per cent—are made by the Forest Insect Rangers on the staff of the Division. These Rangers number about 75 and they are men who have been trained “on the job” gradually acquiring experience as time passes. Each is responsible for a district, from which representative samples have to be returned, and also for liaison with voluntary co-operators (foresters, fire rangers, and others) who submit the remaining 10 per cent of the collections. All of the information obtained from these samples is recorded on punch cards whilst the reared and identified material is included in the extensive and very useful reference collections located at the various laboratories. In general, it can be said that the forest insect survey provides a broad basis of knowledge which is of value in itself and which also automatically indicates and materially assists intensive research projects.

A second field of activity is that of chemical control where the Division has a section, based on the Ottawa laboratory, which carries out research with the aim of improving the techniques and economics of treatment. The Division itself is not, however, responsible for carrying out control schemes but only for advising when and where they are necessary and for recommending the treatments to be used. Nonetheless, the Division's resources become heavily committed in delineating treatment areas and in assessing the results of spraying when large scale control operations are embarked upon. This aspect of their work was seen particularly during the aerial spraying operations carried out against the spruce budworm in northern New Brunswick and eastern Quebec where, in 1957, some 6½ million acres of forest were treated. The spruce budworm, despite its name, is primarily a pest of balsam fir (*Abies balsamea* (L.) Mill.) although it will also feed upon spruces. Cycles of dry weather favour the initiation of outbreaks; and epidemics usually arise in mature or over-mature stands of balsam where the staminate flowers provide highly nutritious spring food and their scars suitable larval hibernating sites. Attack is usually heaviest upon current year's foliage, although older needles are fed upon, and so normally a number of years of defoliation have to take place before the death of the tree occurs. In deciding which areas require treatment, the surveys carried out by the Division's staff take into account two factors—(1) the extent of past de-

foliation and (2) the probable larval population in the following season as revealed by counts of egg masses in the tree crowns. These together indicate the risk of tree mortality and hence the necessity or otherwise of resorting to chemical treatment. Advice on the timing of the spraying is another responsibility of the divisional staff. Protection of foliage calls for early spraying; high kills of the budworm are best achieved by late spraying when most of the feeding is completed and larval exposure is at a maximum. In practice, the timing decided upon is the best possible compromise between these two conditions, and its nomination is based on observations of both insect and foliage development. Finally, the Division's staff check the immediate results of the spraying by comparing defoliation and post-spray larval survival in sprayed and in unsprayed areas.

My visit to northern New Brunswick coincided with the spraying period so that I had the opportunity of seeing the organisation in action. Some 200 Stearman planes, based on 21 airstrips that have been constructed for the purpose since 1952, were used to apply $\frac{1}{2}$ lb. of D.D.T. in $\frac{1}{2}$ U.S. gallon of oil solvent per acre. The planes, worked in pairs and groups of pairs, were supervised by inspection pilots who judged the suitability of the weather for spraying and who checked on the standard of flying and of placement. (Plate 3, Central Inset). Apart from the sheer size of the operation, the main differences between the Canadian methods and the ones we used here in 1954 were (1) that no ground markers were used, the pilots orienting their flight lines on topographical features or compass bearings, and (2) that the spraying was done at heights of 75 to 150 feet above canopy instead of the 10 feet used here. The main reasons for flying at this height are safety and the desire, with the low application rate, to obtain maximum drift coverage effect. The Stearman spray planes had a payload of 150 gallons so that the 22 planes operating from Nictau, the strip at which I spent most time, could treat 6,500 acres in one sortie, which would take slightly under an hour.

It is rather difficult to summarise the results of these spraying operations. The five years spraying programme has certainly not eliminated the epidemic, although to date some 12½ million acres have been treated, and its continuation does not appear likely to do so, since high numbers are being maintained by the resurgence of residual populations and by invasion from unsprayed areas. Already some areas have been sprayed four times and the present view is that spraying every second or third year will be necessary to keep the trees alive for so long as the infestation persists. Usually epidemics of the budworm collapse only through starvation when extensive tree mortality occurs, and since the spraying itself is preventing this happening it is difficult to see where the story will end. One thing, however, is being gained; additional time in which to harvest at least parts of the threatened crop. It is hoped to use this time to help to bring about changes in species composition and diversity of age-class which should, in the long run, reduce the danger of recurrent outbreaks in "budworm-type" forests.

One of my regrets about this trip was that the Division had arranged such a tight "insect-only" schedule for me that I had few chances of meeting foresters and of seeing normal forest operations, but in this respect, on my last stop on Vancouver Island, the situation was rather better. There, thanks to contacts with the British Columbian Forest Service and with a number of logging companies, I was able to see some of the magnificent virgin stands and some of the heavy logging operations which take place in them and which so impress visitors. (Plate 4, Central Inset). On my last day in a Canadian forest I was lucky enough to be shown what are believed to be the oldest living things in Canada—a group of six Douglas firs of 1,345 years of age. They were discovered

in 1957 when an extraction road was being constructed through an approximately 600-year-old stand of predominantly Douglas fir and Western red cedar. One of the group was felled during the road line clearance and its age revealed. My photograph of one of these trees is unfortunately not good enough to reproduce (there is not overmuch light inside such a stand!) and in any case would not have been very impressive since the trees were not of particularly good form and showed marked dieback of the tops. We stood and admired them for some time, pondering on their long history; and it was a good antidote for me, after having seen so many insect plagues and so much damage, to be made to realise that despite it all the forest still flourishes.

ALICE HOLT LODGE AND FOREST

By E. F. HALE

Clerical Officer, Research Branch

This article is something of a miscellany made up for the most part of interesting bits of information relating to Alice Holt Lodge and its surroundings, that have come my way during the last few years. For fuller surveys see "Alice Holt Forest: Contributions to its History" by G. D. Kitchingman, *Journal of the Forestry Commission* 1955, and "Historical Notes on the Forests of Alice Holt and Wolmer" by W. H. Dixon, *Journal of the Forestry Commission* 1956.

The Lodges

A question often asked is—How old is Alice Holt Lodge? I am unable to give an exact date but we can narrow down the date of its construction to the period 1800-1816 for I have a copy of a letter written from 'Alice Holt Lodge' in 1816. A map of the district dated 1814, but possibly surveyed up to ten years previously, shows not "Alice Holt Lodge" but the "Great Lodge". This leads to another query often posed—"What was the site of the Great Lodge?" A comparison of the modern 2½ inch O.S. map with a map of the county by T. Milnes shows that Alice Holt Lodge is identical with the Great Lodge.

How many centuries the Great Lodge was in existence is hard to say but I have traced its history back to Henry VIII in 1530 when Sir William Sandys was granted Worldham Manor and Alice Holt. Later he was created first Lord Sandys and as Lord High Chamberlain he was one of the Commissioners who arranged the meeting with Francis I on the Field of the Cloth of Gold. As he was a devout Catholic he found the Great Lodge very conveniently out of the way of the Protestants of the Court. In a letter in 1530 he said he had been constrained to live in a poor little lodge in the forest. This "poor little lodge" being the Great Lodge—a large building with 143 acres of farm land. During the reign of James I there is an estimate by John Norden, in May 1609, "of the particular charges for repairing the Lodge in Alice Holte Forest, Hampshire".

In the latter part of the 18th century, Lord Stawell appears to have been in residence, for there is an account of "sums expended by Lady Hillborough and himself in repairs and buildings in the forest from 1778 to 1788, both inclusive, amounting to £5,673 6s. 9d."—which was a very large sum for those

days. The value of this expenditure can be judged by the following payments his Lordship made to his keepers:—

William Moore Junior. Keeper of Goose Green Lodge, Salary paid by Lord Stawell £26 5 0.

Henry Howe, Keeper of Old Close Walk occupies part of Goose Green Lodge and a small garden, the other part occupied by Lord Stawell's game keeper. Salary paid by Lord Stawell £20 0 0.

. . . On the other side of the account Lord Stawell reckoned the Great Lodge, garden and pleasure grounds and lands within the pale, about 143 acres to be worth the payment of a rent of only £100 a year.

When the Great Lodge was demolished is rather uncertain but it was probably at the beginning of the 19th century when the present building was erected on or close to the site of the Old Lodge.

The earliest note I have of Alice Holt Lodge is a copy of a letter dated 1816 which is interesting as it refers to the oak now reaching maturity and being felled in various parts of the forest. Here it is:—

Alice Holt Lodge.

25th June, 1816.

Sir,

I beg leave to acknowledge the receipt of your letter of the 22nd instant; respecting the mischief done by the hares in the plantations in Alice Holt Forest and to acquaint you for the information of the Commissioners of His Majesty's Woods etc. that the injury which the Hares did to the Oaks last Winter was to a great extent and I think from the observation which I took of them before they were in leaf that there is not more than one tree in twenty of which the Hares have not eat off the top; With respect to Lord Stawell's keepers endeavouring . . . to keep down the number. I understand, they do every thing in their power to increase them, and I am confident, that if some step is not taken to destroy them, they will destroy all our trees,

I am etc.,

To A. Milne Esq.,

Signed C. F. Wise.

Not much seems to have been known of Alice Holt Lodge during the 19th century except that it was never in the possession of one family for very long. In 1850 according to the *Book of Binsted*, it was let to a Mr. Higginbottom and at the turn of the century it was leased by the Ackroyd family and the occupiers since were:—

1906—1917	Herbert Manwaring Robertson
1917—1920	Mrs. Herbert Manwaring Robertson
1921—1923	Sir Henry Bax Ironside, K.C.M.G.
1924—1940	Mrs. Fisher
1941	Colonel and Mrs. Panton
1942—1943	Messrs. Hollis and Gower
1944—1946	A Military Rehabilitation Hospital.

The story of the house and its grounds from 1900 to the beginning of World War II is fascinating, as various occupiers spent large sums of money in improving the building and beautifying the grounds. Some of the people who remember those days are still alive and in particular Mr. A. Collins, erstwhile Head Gardener for over 20 years and now a spry and active 83, has told me

some amusing stories of people and things. It was he incidentally who found, nearly 40 years ago, a copper coloured beech seedling in the forest, and having received permission he planted it on the back lawn where it remains, having grown exceedingly and is admired by all.

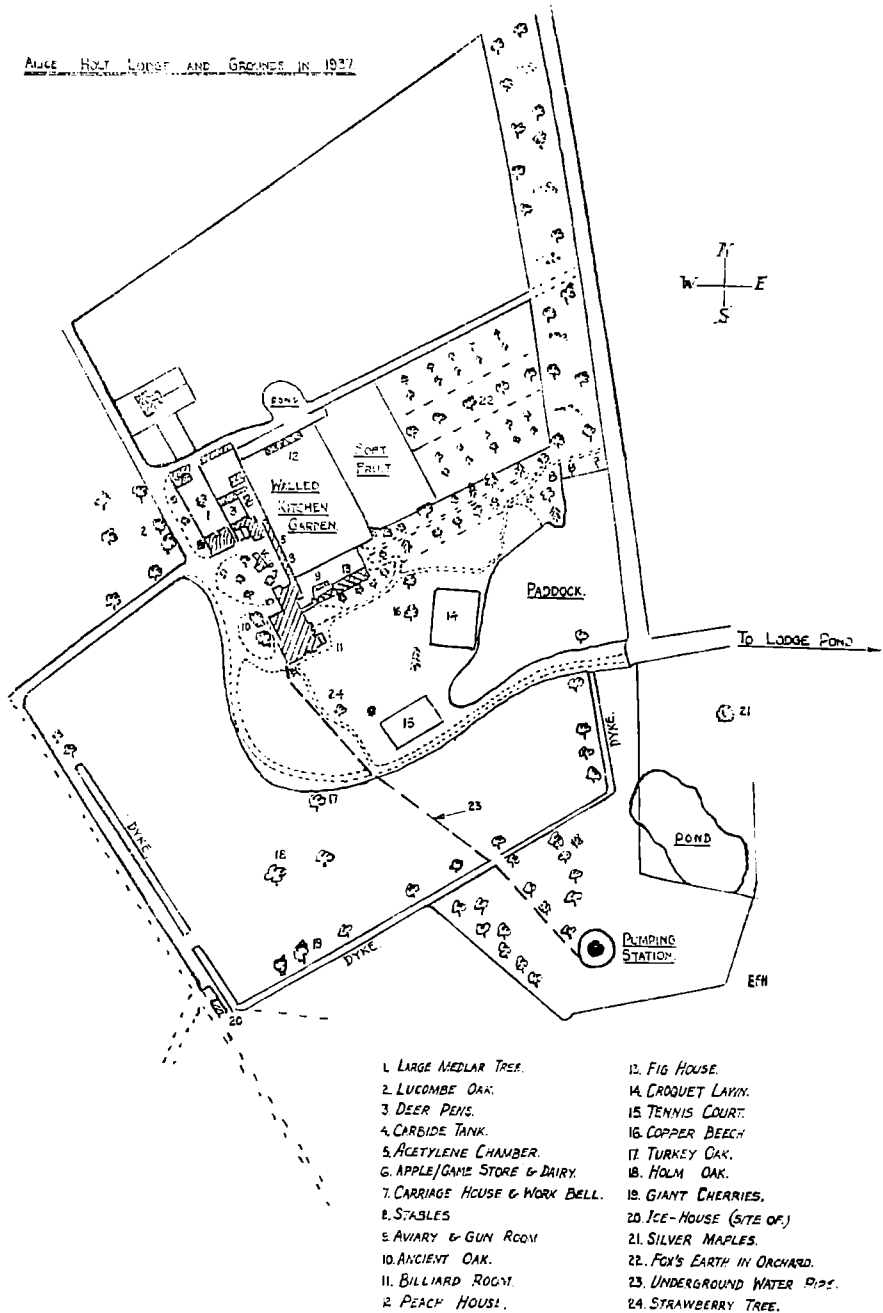

Fig. 2. Plan of Alice Holt Lodge and Grounds in 1937.

To illustrate some of the more unusual aspects of the Lodge I have drawn a sketch map (Figure 2) to show what the place was like before the last war. One thing you are sure to notice is the "Dike" still in existence and holding a foot or two of water. All kinds of theories have been aired as to the real purpose of this huge ditch which averages 20 to 25 ft. in width and 6 to 8 ft. depth. One popular idea is that it was used to produce ice to be stored in the ice house, but other people remember loads of ice being brought by farm cart from Lodge pond to fill the ice house. Another suggestion was that the house side of the ditch was cut steeper in the past to combine with a few feet of water to keep the deer out instead of having a fence which would spoil the view. The third, and I think the correct reason is that it was made in an attempt to prevent some of the floods that were prevalent before the forest had an efficient drainage system. That the forest drainage has been greatly improved since the 1920's is evident for now we have no floods even in the wettest seasons; yet only 35 years ago it was common for floodwater to fill the Dikes and overflow to make a sheet of water right up to the house where it poured down into the cellars and extinguished the boilers.

The "Pumping Station" and pipeline are prominent on the map and they are still looking much as they did over half a century ago when it was the stable-boy's job to flick the pony every now and then with a long sapling to keep it walking round. This one-pony-power pump forced the water along an underground pipeline about a quarter of a mile to the water tanks in the roof of the Lodge. The ring of laurel and elder bushes around and over the pump were planted as shade from the sun and to keep off the flies. They are still alive and flourishing. In those days the pond just behind the "Pumping Station" was a favourite place for duck, and nowadays a few can usually be found there, an easy way of approach with a 12 bore gun being along the Dike until it bends opposite the pond.

Underneath the cobblestones in the stable yard was a large rectangular tank for carbide and water connected to a circular gasometer in one of the stable buildings. When the house was lighted by acetylene gas, pipes ran from this apparatus to all parts of the ground floor. At the back of the stables were the deer pens—dwarf brick walls surmounted by tall iron railings—where enough animals were kept to provide good hunting.

At the front of the house is a small square of flat roof which served as a base for clay pigeon projection, the "pigeons" were catapulted from this eminence by the gardener's boy for practice shooting by the guns below. The apple store, dairy, and carriage house were in the stable yard where hung the big bell that rang for the workmen at 7 a.m., 12 noon, 1 p.m. and 5.30 p.m.

What is now part of the Library in the east corner of the building used to be the Billiards room where once an Italian painter spent some weeks perched on trestles applying his own colourful design to the ceiling. The result appears to have been heartily disliked by most people for we hear of it being hastily covered up again.

Growing in the Dike are some sweet cherry trees or Gean (*Prunus avium* L.). (Plate 8, Central Inset). These trees are very old and the most well preserved specimen is a shapely giant girthing over 10 ft. at breast height and being about 65 to 70 ft. tall. Now that the huge cherries in Leigh Woods, Bristol have been felled this Alice Holt tree must rank as one of the largest in the country. (There is a tree 70 ft. \times 10 ft. 8 in. at Lexden Manor, Colchester and another of 70 ft. \times just over 11 ft. at Chawton, Hants.).

Alice Holt Forest

At the Domesday survey, Alice Holt with Wolvermere (Woolmer) was held under the keepership of the Lord of the Manor of Worldham as a grant from the Crown.

Although a good deal has been written of the history of Alice Holt Forest I think there is still, at the Public Record Office, a lot of interesting material if ever anyone can find at least a few weeks to unearth it.

From the Calendar of State Papers we can read in the King's Payments (Henry VIII, 1538) "to Sir Frasn Bryan on warrant of 14 Dec. for taking of 120 Quick deer and 80 quick deer of antelere within His Highness' chase of Alice Holt and for conveying of them to his park of Asshere towards the replenishing of same after the rate of 3/4d. a piece".

In the reign of Charles I, 1630 there was: "a petition of the inhabitants of Chertsey for the repair of Chertsey Bridge. The King granted a reference to the Lord Keeper for a collection, but he and the council thought it fit not to raise money in that way for building the said bridge. Pray warrant for the sale of trees. The sum to be raised was 555L of which sum 350L was suggested to be raised by the sale of trees in Alice Holt, near Farnham".

On 25th May 1632 we can read: "Recommend Edward Boate and Peter Pett to build the new ships for 1633 whose plots are answerable to those of the Nonsuch and Warspite of burthen between 500 and 600 tons, the one to be framed in the New Forest the other in Alice Holt".

September 12th 1632. "Mr. Pett is forward in Alice Holt and the timber proves excellent". Then there is mentioned: "Stephen Danske concerning the land carriage of 1,200 loads of His Majesty's timber out of the Forest of Alice Holt in Hants. to Hamhew to the water side there being 20 miles".

May 27th 1634: "At the Holt where he met with one of the Verderers, all the Keepers and divers of the Regarders. They had conference of many things amiss in the Forest. On Thursday he is to meet Sir Walter Tichborne about examination of those deer stealers whom they suspected heretofore. There has been a great fall of trees in the Holt for building ships for His Majesty this year past, and last summer there was proclamation made for all the country to come in and buy lops and tops, in the fawning time, and by the multitude of disorderly people that came under that colour all the fawns for the most part were destroyed and many of the old deer stolen and . . . feared away . . .".

11th December 1638. "Henry Earl of Holland Chief Justice of the Forests on this side Trent to the keeper of the Marshalsea. To receive into his custody Jonas English of Farnham, Surrey, joiner accused of killing and stealing deer in the forest of Alice Holt and Woomer, Hants. and to keep him until he receives direction from the Earl for his enlargement".

Warrant of the Council of State 17th November 1653:

To Serjeant Dendy. "To apprehend and bring before the Council Edw. Rowe, keeper of the Great Lodge walk and Rob Corfe keeper of the Olde Close Walk Alice Holt Forest to answer for spoil of timber".

Samuel Pepys as Clerk of the Acts of The Navy was at this time on the bottom rung of the ladder that was to lead him to Secretaryship of the Admiralty, and with untiring industry he looked into every possibility for the supply of navy timber so that we find a certain William Cooper having to report . . .

November 22nd 1662. "William Cooper to Samuel Pepys. In surveying the trees in Aylesholt Forest, but finds them fewer and more scanty in substance than expected". and further . . .

November 27th 1662. "Account by Wm. Cooper of timber trees surveyed in Alice Holt Forest. 934 loads. The total charge of felling, hewing and carriage will be . . . 1L. 5s. 4d. a load".

1663. "Warrant to the High Court of the hundred of Woking for providing timber for use of the Navy. 100 sufficient teams and carriages with horses or oxen to carry timber from Alice Holt to Chertsey Haw at the rate of 1s. load per mile to be charged on parishes and places within 12 miles of the forest".

The timber was taken to the shipyards by wagon which brought back discarded timber for house and farm building, but the hiring rates were so low that the utmost difficulty was always experienced in getting enough wagons and teams to move the timber.

The Middleton report of 1790 brought to light serious abuses by many of the eminent people who held the office of Lieutenant or Keeper of Alice Holt. During the 17th and 18th centuries much of the profit on the timber was going into the pockets of the Office holders. One astonishing document I happened to find seemed on the face of it to show that the forest had been leased and then leased again on the same day at a profit of £2,500. Here is a copy of it . . .

15.3.1741. Assignment from Thos. Levett, administrator to Emmanuel Scroop Howe, to Jn. Mordaunt Esq. of Alice Holt and Woolmer Forest for £3,000.

15.3.1741. Assignment from Jn. Mordaunt to Andrew Telfe of Alice Holt and Woolmer Forest for £5,500.

Alice Holt Forest in the 18th century must have been a familiar venue for sportsmen from all over Southern England as the Cricket ground at Holt Pound on the edge of the forest is clearly marked on the Geometrical Survey map of 1787. Here—to quote from the history of Wrecclesham by S. Evelyn Hicks—"To the family of Beldam, in 1766, was born a son, William, who soon, with early boyhood, gave promise of being a leader at games as well as other interests. The green at Tilford became his rallying place. Every fine evening from early spring on he would challenge all and sundry to the fine old English game of Cricket. Known as "Silver Billy" from his thatch of thick light hair, gradually men took note of his keen eye, supple wrist and swift batting skill. With manhood, his name became a byword, and from far and near, for many a year, at the Holt Ground, behind the Forest Inn, as well as in other places, thousands came to see this son of a Wrecclesham worker lead his team to victory. With his brother-in-law, John Wells, and others, his team vied with some of the best in the country, but he reigned supreme, talking "cricket" day in and out to all who would gather around him. An admiring follower erected an inn to these men, Beldam and Wells, called the Cricketers at Wrecclesham, and advertised the "Village's best beer as drunk by these famous men". Trade therein never lacked customers. He passed to his rest in 1862, having played for thirty-five years "Great Cricket". By this he did more in a pastime to inculcate self-control, fairness and straightness in contests than he ever dreamed of as he watched the seasons slip by with his own increasing years. The Oval in London takes its name from the original Oval at Holt Ground, Alice Holt Forest, where Beldam played many of his famous matches".

If in the 16th and 17th centuries the forest of Alice Holt was renowned for its ship timber and deer, it must have been quite as well known to the Romans in the 1st to 4th centuries. We can read in "Alice Holt Forest—its history and its Romano-British potteries" by Major A. G. Wade, M.C., that the Roman settlement here was on a most intensive scale, its potteries, centred in the forest at Abbots Wood and Goose Green inclosures, extended from Kingsley to

Farnham and into the Tilford area, and when in full blast must have nearly resembled Stoke-on-Trent. Major Wade has found pottery from the Claudian period A.D. 43—69 right through to the 4th century, and complete dishes, bowls, cooking pots, stone jars and flasks have been made from the pieces.

The potteries were worked over a very long period and were so extensive that even now the potsherds lie in great dumps in the forest, and one pottery mound alone produced enough sherds to make the farm road at Goose Green. By the end of the 4th century A.D. large areas of Alice Holt and adjoining forests had been denuded of oak for firing the numerous kilns.

The late Head Forester of Alice Holt—Anthony Simpson—who retired in 1933, wrote in 1945 that “The Barony of Goosegreen was situated almost in the centre of the meadow east of Forest Lodge (the Head Forester’s house). The Moat is well defined to this day and can be traced in an almost true rectangle. To the immediate north side of Forest Lodge and quite close to the north wall is quite clearly seen the graves (especially in spring) or Cemetery of the Barony and are all laid west to east”. Mr. Simpson tells an amusing story of pottery finds, he says . . . “when the order came out for all rabbits to be destroyed Richard Bonner was a gamekeeper in Alice Holt forest later known as ‘Old Dick the roadman’. He told me that when “rabbiting” in Park Piece he unearthed a shard (Mr. Simpson means a pot or “waster”) and not the first either. He took it to Judge Wright who lived in the neighbourhood and was interested in Archaeological finds, and received therefor “one golden guinea” with instructions to bring others for which a guinea would be paid. Judge Wright had a good many”.

NEW ACQUISITIONS IN ENGLAND

Note by Staff of Director, England’s Office

Miterdale Estate, Cumberland

In December 1957, the Commission completed the purchase of 906 acres of Lord Rea’s Miterdale Estate, for an addition to the forest then known as Irton Forest. In view of the fact that this acquisition is the largest component of the forest, the name has been changed to Miterdale Forest.

Included in the purchase was a farm of about 142 acres, which it is proposed to retain and integrate with forestry. There are 687 acres of plantable land, which should be planted within 10 years, mainly with Sitka spruce, Scots pine and Japanese larch.

Miterdale is reputed to be haunted. A local legend says that someone is buried in one of the old farm buildings and no farmer will put anything into this barn.

Wolseley Park Estate, Staffs.

A useful addition to Cannock Forest was formed by the acquisition from Sir Eric Wolseley in July 1958 of 420 acres of Wolseley Park.

The park contains the site of an ancient deer leap, by which deer could enter the park from Cannock Chase. They could not get back again, however, so Sir Eric’s predecessors no doubt acquired a large herd of deer and plentiful supplies of venison. The original licence for making the deer leap is believed to be still in existence.

GLENETIVE AND BARRS

By D. GRAHAM-CAMPBELL

District Officer, Scottish Directorate

The Estate of Glenetive and Barrs, part of which was acquired in October 1957, was under the management of the Department of Agriculture. It was formerly owned by Colonel Anderson who had gifted it to the Secretary of State on condition that it was used as an experimental hill farm. The Department of Agriculture had found that the shepherding of the Barrs section of the estate was difficult to manage, and they decided to ask Col. Anderson whether he would agree to part of the estate being used for forestry purposes. Colonel Anderson approved of this suggestion and 2,239 acres of plantable land have now been placed at the disposal of the Forestry Commissioners, with the possibility of more to come. It has now been provisionally agreed the remainder of Glen Etive Estate including 2,000 acres of plantable land will pass to the Commission. (Plate 6, Central Inset.)

Loch Etive Forest, situated on the north shore of the loch within the proposed National Park area, must be one of the most isolated properties in Britain. The nearest village is in Glen Coe which is 20 miles away by road, and a launch from Etive Pier runs to Taynult three times a week. On the shore of the loch there remain some oak and birch woods, probably at one time exploited for smelting iron, and the Commission has undertaken to preserve these as far as possible.

This estate provides a further example of land coming to the Commission because of isolation and shepherding difficulties.

RANNOCH BARRACKS

By R. d'O. P. JACKSON

District Officer, Scottish Directorate

Rannoch Barracks, acquired in 1957, lies in Perthshire immediately west of Dall and covers 14,165 acres of which 3,115 acres are classified as plantable and are available for that purpose. Roughly 3,000 acres will remain as a sheep farm and it is interesting to note that for over 50 years it has been worked as one with the adjoining farm of Finnart on Dall Estate, though for much of the time the estates were owned separately. By purchasing them both, the Forestry Commission has restored the farms to single ownership.

The estate itself runs out on to Rannoch Moor, a great tract of wild and lonely countryside many square miles in extent with no roads or tracks of any kind, other than the railway, crossing it. That part of the Moor which was included in the estate is now the property of the Nature Conservancy.

The name of the estate arises from the fact that the Government established an army barracks here after the '45 rebellion in order to keep control of the local population who were reported to be "in a barbarous and uncivilized condition". Travellers crossing the Moor on the West Highland railway line can still see trenches dug at that time by the military.

Today practically the whole area is covered with peat but there is ample evidence in the form of buried roots to show that it was once wooded. It will no doubt take time to establish a new forest in this bleak countryside, most of which is over 1,000 feet above sea level, but we can look forward to the day when trees are once again growing there.

DALL

By R. d'O. P. JACKSON

District Officer, Scottish Directorate

This Perthshire estate lying on the south side of Loch Rannoch was acquired in 1957. Out of a total area of 26,110 acres the Forestry Commission will eventually control 21,188 acres (including 7,323 acres plantable). Most of the balance comprises the sheep farm of Finnart which will remain in existence.

By purchasing this estate the Forestry Commission has now acquired the whole of the Black Wood of Rannoch. Part of this remnant of the old Caledonian Forest was already included in Rannoch Forest and was described in the Journal for 1949. The wood covers about 900 acres and consists of Scots pine, many of which are 250 years old and more. Due to exploitation over the centuries however, it is now only a shadow of what it must once have been. Because of its ecological and historical interest a block of 240 acres was set aside in 1955 to be used by the Research Branch for special study.

The estate is well known in sporting circles, red deer, grouse, blackgame and capercaillie all being common. In this connection a former owner, Capt. Wentworth, was noted between the wars not only as an expert shot but also as a curler who used to skip his own estate Rink to victory on many occasions.

The Commission already owned 5,112 acres round Loch Rannoch before Dall and the neighbouring estate of Rannoch Barracks were acquired. With these additions our property now covers over 45,000 acres of which about one third are plantable and available for this purpose. This part of the country is rather sparsely populated, the economy being based on sheep farming, sport and hydro-electricity; forestry developments augur well for its future.

THE PERMANENT SEED IDENTIFICATION CODE

By J. D. MATTHEWS

District Officer, Research Branch

(1). The new seed identification code system has been in operation for two years and increasing quantities of seed and plants bearing the new identity numbers are reaching nurseries and planting sites. The purpose of this note is to explain the objects of the new system, what it means and how it works. A list of the most important seed identity numbers is given for reference purposes and two maps illustrate the way the numbers are applied in Britain and the north-western American coastal region.

The Objects of the Code

(2). The permanent seed identification code is linked with the preparation of the Register of Seed Sources for both home collected and imported seed. This register contains details of classified seed sources in Britain and as time goes on will provide similar information for seed sources abroad. The register is being added to each year and it is desirable that it should be set out in a systematic manner using a seed identification code system which is (1) readily applicable to both home collected and imported seed (2) capable of expansion (3) readily indicates the origin of the seed or plants (4) consists entirely of numerals for convenience in keeping records.

(3). Seed used in British forestry both for large scale planting and for research purposes, comes from very widely scattered areas of the world and there are obvious advantages in using an existing system of numbers. The one selected is the Universal Decimal Classification, published by the British Standards Institution, which gives place numbers for the majority of the countries of the world. Figs. 3 and 4 illustrate the principle. The way in which the Universal Decimal Classification has been adapted for seed identification purposes is as follows:

The first digit within the brackets indicates Continents: e.g. (4) Europe.

The second digit within the brackets indicates larger countries and major Political Divisions: e.g. (42) England and Wales.

The third digit within the brackets indicates small countries and larger Provinces, Regions and Zones: e.g. (421) South-East England.

The fourth digit within the brackets indicates British Countries, French Departments, etc. and small States, Provinces and Zones: e.g. (4215) Sussex.

One or two digits outside the brackets indicate seed collection areas or classified seed sources which are considered to be important for practical purposes: e.g. (4215) 1 Slindon Wood, Slindon Park Estate.

Three digits outside the brackets indicate a Research Branch Collection made for experimental purposes only: e.g. (4215) 100 a single tree within Slindon Wood.

(4). When seed or plants from any seed source are distributed the seed identity code number is accompanied by two additional items of information which are also coded (1) the species name (coded as per SM.37) and (2) the crop year, i.e. the year in which the cones, fruit or seed have ripened. Thus, for example, Be. 58 (4215) 1 describes mast collected in the crop year 1958 from the Plus Stand of beech in Slindon Wood on the Slindon Park Estate and the full details of the boundaries of the stand and the quality of the trees can be found under (4215) 1 in the Register of Seed Sources.

Because the identity numbers are permanent all mast collected in any year from this seed source receive the same identity number, e.g. Be. 60 (4215) 1 and so on.

How the Code works in Practice

(5). The ultimate aim of the work being done on the many aspects of seed supplies in Britain is to ensure that all the seed used in British forestry comes from selected seed trees growing on specified areas. It will require some years of continuous effort to reach this goal and at present seed lots and the plants derived from them are of four kinds (1) General Seed Collections; (2) Collections from certain Specified Areas and Stands Classified as "Plus"; (3) Small Collections of Local Interest; (4) Research Branch Collections.

(6). General seed collections are those in which seed has been collected over considerable areas (e.g. Douglas fir from several seed collection points in the northern coastal region of Washington, U.S.A.) or from a number of stands which are of normal (i.e. average) quality or are unclassified (e.g. beech from several stands in eastern England). These collections are made to meet specific demands and the collection areas or the seed trees or both are more or less unselected. These general collections are bulked together in the two central seed stores at Alice Holt (for England and Wales) and Tulliallan (for Scotland) into large lots, mainly to reduce unnecessary record keeping and for practical working. The seed identity numbers used consist of two, three or four figures within the brackets, e.g. DF. 58 (7971) describes Douglas fir seed of the crop

year 1958 collected at two or more collection areas in the northern coastal region of Washington.

Similarly Be. 60 (425) would describe a general collection of beech mast made in eastern England in the crop year 1960.

(7). Collections from certain specified areas and stands classified as Plus are kept separate and given a distinguishing suffix number outside the brackets when the varieties associated with these areas or stands are known to be or show promise of being of practical value. For plus seed sources in Britain both the boundaries of the stand and the characteristics of the trees are known and described, e.g. Be. 58 (4215) 1 Slindon Wood, Slindon Park Estate; whereas a good variety from abroad may only be identified at present by means of a place name, e.g. DF. 58 (7974) 5 Darrington. Most forest services in Europe and elsewhere are now building up Registers of Seed Sources and the Manning seed firm also market "Bonded Maningseed" for which both the area of collection and quality of seed trees are guaranteed. This kind of seed lot will become more common as time goes on and seed collected from seed orchards will also receive the suffix numbers to distinguish the varieties permanently.

(8). Small collections of local interest are small quantities of seed (e.g. 2½ lb. of beech, 5 lb. of acorns or less than 1 lb. of conifer seed) collected from single trees or small groups of trees of local interest. It is not necessary to apply the full recording procedure to such seed lots unless there is a special reason for so doing.

(9). Research Branch Collections are generally small in size but are made for experimental purposes and so require accurate recording. Research Branch have devised an extension of the permanent identification code system and where necessary will use three digits outside the brackets to distinguish them. Silviculturist South has been allocated the numbers 100-499 and Silviculturist North will use 500-999. Thus PC. 58 (4122) 500 describes a collection of *Pinus contorta* seed made in the crop year 1958 by Silviculturist North in Experiment 12, Culbin Forest, Morayshire.

How the Code Numbers are Allocated

(10). Code numbers for imported seed are allocated at the Central Seed Store at Alice Holt which handles all imported seed.

Code numbers for home collected seed will eventually all be found in the Register of Seed Sources, copies of which are held by each Conservator. The Register for home seed sources is not yet complete because the survey on which the Register is based will not be completed until 1961. For the present, numbers for seed collected from *Unclassified* seed sources are allocated by the Conservator in whose Conservancy the seed has been collected—using the Region (three figure) identity numbers.

A Summary of Essential Information

(11). The permanent seed identification code system was devised to enable the comprehensive Register of Seed Sources to be compiled and added to over a long period of years.

(12). General seed collections receive identity numbers within the brackets; Collections from specified areas or stands classified as "plus" receive one or two distinguishing suffix numbers outside the brackets; Research Branch collections are further distinguished by three digits outside the brackets.



Fig. 3. Seed Collection Zones in Great Britain.

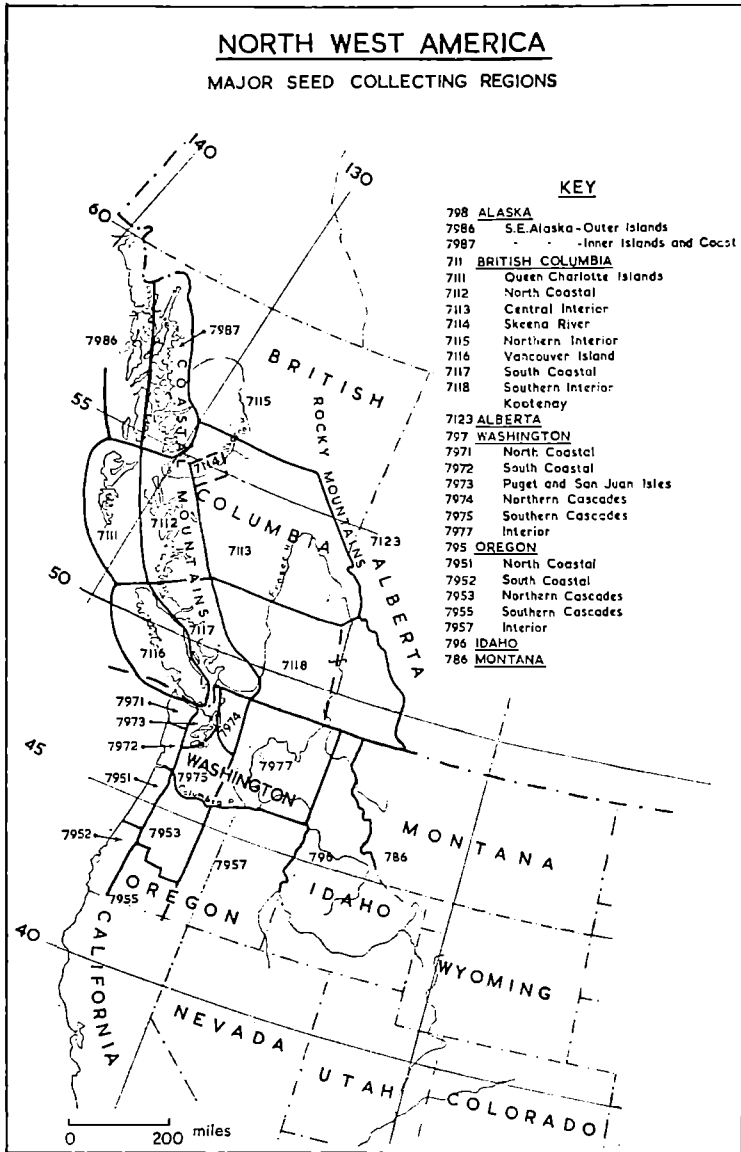

Fig. 4. Seed Collection Zones in Western North America.

APPENDIX

A List of the Most Important Seed Identity Numbers

- | | |
|--|--|
| (4) EUROPE | (495) Greece |
| (41) Scotland. (See Fig. 3 for details.) | (4971) Jugoslavia |
| (415) Ireland in general | (4972) Bulgaria |
| (416) Northern Ireland | (498) Rumania |
| (417) Eire | (5) ASIA |
| (42) England. (See Fig. 3 for details.) | (51) China |
| (4279) Isle of Man | (512) South-east and Central China |
| (428) North Wales. (See Fig. 3 for details.) | (513) South-west China |
| (429) South Wales. (See Fig. 3 for details.) | (518) Manchuria |
| (43) Germany | (519) Korea |
| (431) North eastern Germany and Prussia | (52) Japan |
| (432) Central Germany | (521) Honshiu (Nippon) |
| (433) South-eastern Germany, Bavaria | (5215) West Central Honshiu (including Nagano) |
| (434) Southern Germany | (522) Kiushiu (Kyushu) |
| (435) North-western Germany | (524) Hokkaido (Yezo) |
| (4359) Luxemburg | (527) Kurile Islands |
| (436) Austria | (5291) Formosa |
| (437) Czechoslovakia | (540) Republic of India |
| (438) Poland | (549) Pakistan |
| (439) Hungary | (55) Iran (Persia) |
| (44) France | (560) Turkey |
| (45) Italy | (5643) Cyprus |
| (458) Sicily and Adjacent Islands | (567) Iraq |
| (4599) Corsica | (5691) Syria |
| (46) Spain | (5694) Israel |
| (469) Portugal | (57) Siberia and Soviet Far East |
| (47) Union of Soviet Socialist Republics | (571) Western Siberia |
| (472) Northern Russia | (572) Central Siberia |
| (473) Central Russia | (573) Eastern Siberia |
| (474) Baltic States | (6) AFRICA |
| (476) Western Russia; Belorussian SSR | (61) North and North-east Africa |
| (497) Southern Russia. Ukraine, Crimea | (65) Algeria |
| (478) Eastern Russia | (68) South Africa |
| (479) Caucasia and Transcaucasia | (7) NORTH AMERICA. (See Fig. 4 for details of main areas.) |
| (480) Finland | (71) Canada |
| (481) Norway | (7123) Alberta |
| (485) Sweden | (7124) Saskatchewan |
| (489) Denmark | (7127) Manitoba |
| (492) Netherlands (Holland) | (713) Ontario |
| (493) Belgium | (714) Quebec |
| (494) Switzerland | (715) New Brunswick |
| | (716) Nova Scotia |
| | (717) Prince Edward Island |

- | | |
|--|---|
| (718) Newfoundland | (793) Nevada |
| (719) Labrador | (794) California |
| (72) Mexico | (795) Oregon. (See Fig. 4 for details.) |
| (73) United States of America | (796) Idaho |
| (74) North-east U.S.A. New England | (797) Washington. (See Fig. 4 for details.) |
| (75) South-east U.S.A. South Atlantic States | (798) Alaska. (See Fig. 4 for details.) |
| (76) South Central U.S.A. Gulf States | |
| (77) North Central U.S.A. and Lake States | (8) SOUTH AMERICA |
| (78) Western States of America Rocky Mountain Region | (83) Chile |
| (79) Pacific States of America | (9) OCEANIA |
| (791) Arizona | (931) New Zealand |
| (792) Utah | (94) Australia |

THE TREATMENT OF THE LESS FAMILIAR BROADLEAVED TREE SEEDS

By H. L. EDLIN

Publications Officer

The following notes are based on a questionnaire circulated some years ago to Foresters in charge of Commission nurseries, and particularly the Research Branch nurseries, where the less usual broadleaved trees are occasionally grown.

ALDER

Selection of Trees

The seed of the common alder, *Alnus glutinosa* L., is rarely required in any quantity, and as it is plentifully produced it is well worth while to make a rigorous selection of seed-bearing trees, so that only the best are propagated. Those selected should be tall, well grown specimens free from any obvious defect or disease. Collection from such trees may cost a little more than from scrubby trees or coppice picked at random, but the extra expense is amply justified. Alder bears seed at an early age, but older trees should be preferred when collecting.

Seed Years and Yield of Seed

Alder bears seed plentifully practically every year.

Season of Collection

The seed is borne in small round false "cones", which are formed in spring but do not ripen until autumn. As they ripen they change colour from green through brown to black, and become hard and woody. At the same time the seed is gradually shed. Thereafter the cones remain on the tree for several years, but such old cones are, of course, empty and useless. For the extraction of satisfactory seed, the cones should be turning brown, and beginning to open, but should not yet have released more than a small proportion of their seed. The actual time of year at which this occurs appears to vary in different parts of the country, and probably from one year to another. October and November are the usual months for collection, but sometimes the cones do not ripen sufficiently until December. It is therefore advisable to keep the trees under observation from September onwards, so that collection can be put in hand as soon as the cones are ripe enough.

Method of Collection

Alder seed is always gathered by picking the ripe cones from the tree by hand. It is seldom difficult to get the required quantity, but where it is desired to get the maximum amount from a few selected tall trees, ladders, hooked poles and long-handled tree pruners should be used to enable the pickers to reach the higher fruiting branches.

Cost of Collection

Alder seed is so seldom gathered in substantial quantities that accurate data as to costs are not available. The cost of collecting the cones is in the region of 9d. per pound, but as several pounds of cones are needed to yield one pound of seed, the cost of collecting the actual seed is around 7/6 per pound.

Cleaning

After the cones have been gathered it is necessary to extract the seed from them. The ideal way to do so is probably to spread them out on trays and expose them to sunlight in an airy place free from strong draughts. Under such conditions the scales open gradually, and if they are occasionally turned over by hand the seed will fall from between them on to the tray.

The application of artificial heat cannot be recommended, as although it will open the cone scales very readily, it may also injure the seed which is very small and delicate.

Some foresters simply leave the cones in a close woven bag, hung in an airy place, and shake it at intervals of a few days. The seeds are thereby gradually released, and fall to the bottom of the bag.

Storage

Although foresters are generally agreed that alder is an unreliable seed, and difficult to store without loss of germinative capacity, opinions differ as to the best way in which to keep it. The simplest way is to store it dry, leaving it in bags in a cool and airy place free from rodents, until the following spring.

Alternatively it may be stratified by mixing it with an equal volume of clean sharp sand, and putting it in a pit in the earth. The pit should be two feet six inches deep and two feet six inches square; the sides should be lined with creosoted boards and the sides, top, and bottom covered with $\frac{3}{8}$ inch mesh netting to exclude rodents; the bottom three inches are filled with pure sand to ensure good drainage, sand and seed are then put in to a depth of two feet, and the top of the pit is filled with a protective layer of pure sand.

Stratification should continue from the time the seed is cleaned to the time it is required for sowing. Both seed and sand are sown together, in their natural moist state.

Miscellaneous Data

Number of seeds per lb.	300,000
(A pound of seed as normally collected contains about two-thirds of this number, the balance consisting of impurities.)	
Normal percentage germination	40%
Weight of normal seed (plus impurities) per 100 square yards of nursery bed	2 lb.
Number of square yards of nursery bed per lb. of seed....	50
Date of sowing	March
Depth of covering	$\frac{1}{8}$ inch of fine silt-free sand

- Notes:* (1) It is important to keep the seedbed moist, and watering should be carried out regularly if conditions are at all dry. The soaking of dry-stored seed, for twenty-four hours prior to sowing, has been recommended.
- (2) The seed of the Oregon alder has been successfully gathered and stored as described above, being stratified from January to March.

BIRCH

Two species of birch, the silver birch, *B. pendula* Roth., and the white birch, *B. pubescens* Ehrh., occur in Britain, but hybrids and intermediate forms are common. When collecting seed it is seldom essential to distinguish between them, but nevertheless if collections are being made in stands typical of one species, the fact should be recorded for future reference.

Selection of Trees

As the supply of birch seed nearly always exceeds the demand, an exacting selection of trees is possible. The specimens chosen should be well grown and free from forking or any tendency to undue development of side branches. Fluting of the trunk is a common defect, and such trees should be rejected, as should any in which the trunk is elliptical in cross-section. Those showing evidence of fungal attack or witches brooms on the twigs should likewise be avoided, as susceptibility to such defects may be inherited.

It is often very much easier and cheaper to collect seed from stunted and scrubby birches than from the tall and shapely ones that bear seed at a greater height from the ground. But such economy is most unwise, and the collectors should be closely supervised to ensure that all seed is gathered from the selected trees, even though this takes longer and involves more effort. It has been suggested that a few good trees might be felled and the seed gathered easily from their branches; but unless good trees are very plentiful it is probably better to retain selected seed bearers to yield in future years. Advantage may, however, be taken of suitable fellings which happen to be made during the short collection period.

Seed Years

Birch seeds very regularly, and seasons in which seed is scarce are practically unknown. Young trees begin to bear at a very early age, ten years or even less. It is preferable however, to limit collection to the older trees, which give more definite evidence of their true form and suitability for timber production.

Season of Collection

In any one locality and in any one year the season of collection is a short one. It varies in different parts of the country and probably to some extent in different years. In the south of England the seed may ripen early in August, whereas in Scotland collection may still be possible at the end of October.

The seed should be tested at intervals of a few days when it appears to be ripening. When it separates from the stalk under light pressure from the hand, it is ready for gathering. At this stage the catkins are still somewhat green on the outside, but begin to open a little and to show the brown seed within. Seed collected before this stage is reached is unlikely to keep well or to germinate freely. If collection is delayed beyond this stage the catkins begin to break up and to scatter their seed, and in a week or two it becomes impossible to secure any quantity.

The period available for satisfactory collection is thus a short one, lasting only about a fortnight. The appearance of a sprinkling of seed on the ground beneath the birch trees is a sure sign that collection must be rushed ahead if seed is to be gathered before it is all shed.

Method of Collection

Birch seed is so minute that hand picking from the ground is out of the

question. It is always gathered in the form of catkins from the growing tree. These catkins break up readily as they dry, and the seed is apt to be scattered by the wind. They should therefore be placed in sacks as soon as they are gathered, along with any pieces of twigs that adhere to them. Picking is done by hand, with the aid of hooked sticks or poles, long-handled tree pruners, or ladders where necessary. The sacks containing the catkins should be hung up for a few days in a dry and airy place, as this drying facilitates the subsequent cleaning.

Cost of Collection

This varies considerably with the density of the crop and ease of access of the trees selected. 1/6 per lb. is a reasonable figure.

Cleaning

Birch catkins consist of seeds and of bracts of similar size and shape that break away from the stalk at the same time. It is neither practicable nor necessary to remove these bracts, which remain with the seed until it is sown. Both should, however, be freed from the stalk, and the stalks themselves removed, as this makes the seed easier to handle and store.

Two methods are commonly adopted to free the seed. The catkins may be spread out on trays and crumbled up with the hand. Or the sack containing the catkins may be knocked lightly against the wall. In either case it is necessary to go over the freed seed by hand and to pick out the stalks and twigs.

Storage

Birch is a difficult seed to store without loss of germinative capacity. Whatever method is adopted, success cannot be guaranteed. Three methods are commonly followed:—to stratify until the following spring, to store dry until the end of February and then stratify for one month, or to store dry throughout.

(a) **Stratification until Spring.** A stratification pit should be prepared as described for alder on page 20.

The seed is mixed with an equal volume of slightly moist sand, as soon as it has been cleaned, care being taken to effect a thorough mixture. It is then put in the pit and needs no further attention, apart from occasional inspection, until the following February. It should then be examined at weekly intervals, as premature germination may make an early sowing advisable. Normally it is sown in early April. At this stage the small seeds should appear soft and plump. Seed, bracts and sand are all sown together. Care should be taken to see that the mixture does not become dry during handling, particularly if it has to be transported any distance. It is advisable to weigh the seed before stratification, as it is impossible to do so accurately later.

(b) **Dry storage followed by stratification.** The seed is first of all thoroughly dried, by spreading out on trays in an airy place out of the wind. If this precaution is neglected, and the seed is tightly packed from the outset, it may heat up and its germinative power be destroyed. It is then packed into close-woven sacks, and hung in a dry and airy place, free from attack by rats, mice and squirrels, until the beginning of February. It is then stratified and sown exactly as described under (a) above.

(c) **Dry storage throughout.** The seed is dried and stored, as described under (b) above, until early in April. It is then sown directly on the seedbeds.

The safest method is probably (a), stratification throughout. If birch seed is stored dry for any length of time it is liable to heat up or to dry out, and may then lose its germinative capacity completely.

Autumn Sowing

If birch seed is sown in autumn it may either germinate at once, or lie dormant until the following spring, depending on local conditions of temperature and moisture. In the south of England where ripe seed can often be obtained in August, it may be worth while to aim for immediate germination, by sowing right away and watering the beds when necessary. The young seedlings that arise should be protected from winter frosts by means of an overhead shelter, such as lath screens. Further north, and under dry conditions in the south, germination is delayed until the spring, and the beds must be kept clean weeded during the winter, as the small seedlings of birch are easily smothered by weed growth on emergence. On the whole, better results are achieved by storage; autumn germinated seedlings may grow so rapidly in the following season that they become too large for easy handling.

Miscellaneous Data

Numbers of seeds per lb. of cleaned seed: 500,000. (A pound of mixed seed and catkin bracts contains roughly one-third of this number.)	
Normal percentage germination	30%
Weight of normal seed (plus bracts) per 100 square yards of nursery bed	4 lb.
Number of square yards of nursery bed per lb. of normal seed	25
Date of sowing	Early April
Depth of covering	$\frac{1}{8}$ inch of clean sharp sand

Note: It is of great importance to sow birch seed on a perfectly clean and firm seed bed with a fine tilth. It should be lightly covered, and sharp clean sand has been found superior to either nursery soil or fine gravel for this purpose. Watering may be necessary in a dry spring. The small germinating seedlings are also susceptible to frost injury, and overhead shelter by means of lath screens may be required at this stage. Losses attributed to defective storage sometimes arise through insufficient care at this critical point.

CHERRY

Several species of cherry are grown for fruit or as ornamental trees, but only the gean, *Prunus avium* L., is of much value for timber production. Collection of seed should therefore be limited to this species and, where any choice offers, the tallest and straightest growing specimens should be selected. The fruit ripens in July and August changing colour from red to black and becoming soft to the touch and sweet to the taste; at this time it is very attractive to birds, who eat the pulp and scatter the stones below the tree, providing a certain indication that the seed is ready for collection. Orchard cherries should be avoided; not only are they, in general, unsuitable for forest planting, but their seeds are often empty and useless.

Collection

Collection by hand from the tree is somewhat difficult, as it usually involves the use of ladders, climbing belts, or long-handled clippers. An average cost of collection is about 1/6 per lb. of fruit, equivalent to about 15/- per lb. of actual stones. Alternatively, fruit and stones may be picked up from the ground below the trees; stones cleaned by the birds are quite acceptable. Whichever method is adopted, the work must be done promptly; the fruit on the tree tends to be scattered by the birds, and the stones on the ground are attacked by mice and other rodents. One pound of fruit contains about 200 seeds; and one pound of stones about 2,000 seeds.

Cleaning

The fruit should be thoroughly cleaned of pulp by soaking in water and then rubbing by hand; rubbing against a $\frac{1}{8}$ inch mesh wire sieve, under water, has been found effective.

Storage

Cherry seed is irregular in its germination, and if careful attention is not paid to storage it may lie dormant for eighteen months or more, or lose its germinative capacity almost entirely. Good results have been obtained by stratifying the seed in moist sand immediately after cleaning. The mixture of seed and sand is taken from the pit in the following spring, and sown at once. At no time should the seed be allowed to become really dry during storage. Protection from mice and birds, by means of $\frac{3}{8}$ inch mesh wire netting, is very important.

Autumn Sowing

Good results are reported from sowings of cherry seed made in the Autumn, just after collection, but such autumn-sown beds are exposed to heavy losses from mice, and the practice cannot be generally recommended.

SWEET CHESTNUT

At the present time it is particularly desirable that all sweet chestnuts (*Castanea sativa* Miller) used for planting in Britain should be raised from home-grown seed. Importation from abroad brings with it the risk of introducing the Chestnut Blight disease caused by the fungus *Endothia parasitica*, from which the British stands of chestnut have so far remained free. Chestnuts imported commercially for eating purposes are, in any case, usually unsuitable for sowing in the nursery, as they have been subjected to kiln drying or other preservative treatment which lowers their ability to germinate.

Selection of Trees

Although in a favourable season sweet chestnuts may bear seed in most parts of Britain, it is only in the more southerly counties that the seed is sufficiently ripened to keep well in storage and to germinate satisfactorily. It is seldom worth while to collect seed in Scotland, or in the six northern English counties of Cumberland, Westmorland, Lancashire, Northumberland, Durham and Yorkshire. Some of the best seed crops are obtained in Kent, Surrey, Sussex and Hampshire.

Trees that yield a useful quantity of well ripened seed are fairly scarce, and the field for selection is not a wide one. In practice it is generally necessary to resort to open-grown park trees, which stand in full sunlight and ripen their seed well. Those selected should be tall, well-grown specimens with a good

length of clean bole. Stunted, short-boled trees should be avoided, together with those that have become stag-headed and are dying back from the top. Particular care should be taken to avoid trees suffering from the Ink Disease caused by the fungus *Phytophthora cambivora*; the usual symptoms of this disease are a withering and a yellowish discoloration of the leaves of the whole tree.

Seed collected from coppice chestnut has given satisfactory results in the south-eastern counties, but, as a general rule coppice should be avoided when making collections. They rarely yield much fully ripened seed, and it is not easy to assess the quality of the parent trees as producers of large sized timber.

Seed Years and Yield of Seed

The yield of good sound seed worth collection is very variable. In most districts a full crop occurs only once in every three or four years. There does not appear, however, to be a definite rhythm of "mast" years, and the deciding factors appear to be ample sunshine during August, and freedom from severe autumn frosts. Hence, a fair crop may be ripened in certain districts, when the crop in others is a failure. In many seasons a partial crop, containing a high proportion of undeveloped seeds, occurs; and in some years virtually no useful seed is ripened.

In a good season a single large-crowned open-grown tree may yield as much as 100 lb. of seed.

Season of Collection

October and November are the normal months for collection, but the season of ripening varies. Sometimes ripe seed begins to fall in the latter half of September, while it is often worth while to prolong the gathering well into December.

The first nuts to fall are often undeveloped and infertile, but once good seed starts to come down, it is important to gather it promptly, even though this means going over the same ground two or three times. Chestnuts are very attractive to squirrels, rats, mice, voles, pigeons, pheasants and unauthorised human collectors, and any good seed left on the ground for more than a few days is liable to be appropriated by one or other of these agents.

Method of Collection

When ripe, chestnuts fall from the tree more or less enclosed in the spiny green cupule in which they have been formed. This cupule may contain three nuts, but more usually one or two fail to develop fully, and only one or two sound nuts are found. The cupule sometimes begins to open before it falls; if it falls in the closed state it often bursts open on striking the ground; it may, however reach and remain on the ground in the closed condition.

In practice, chestnuts are always gathered from the ground beneath the trees. Collection of the spiny cupules from the tree, in addition to being difficult, would probably result in a high proportion of unripe seed being gathered; but it may be worth while to shake the branches to encourage the fall of nearly ripe seed. The collectors find the nuts either within the fallen cupules, or close to them, scattered on the ground. If the cupules remain closed, they may be opened either with a gloved hand or a light blow with the toe of the foot; stamping with the heel, or striking with a stick, should never be done, as rough treatment may bruise the seed within the cupule.

Since collection is by hand-picking, no subsequent cleaning is needed, and the collectors can also exercise a great deal of care in the selection of sound seed, which is most important with this species.

Selection and Rejection of Seed

Good chestnut seed has a uniform bright brown colour, is plump, firm, and heavy to the touch, and separates readily from the cupule. The actual size of the seed is not of great importance, provided it is well filled and thoroughly ripened.

Seeds to be rejected are:

Empty, undeveloped seeds.

Partially ripened seeds, which are still white on all or part of their surface.

Seeds attacked by weevils, which can usually be detected by their light weight and the presence of small exit holes.

Cost of Collection

Chestnut seed lends itself very well to collection on piece work rates, as the quantity gathered in a given time depends very largely on the energy and interest of the collectors. Moreover, as the undeveloped seeds weigh very little, collectors who are paid by the pound soon learn to reject all such seeds, as it is not worth their while to include them. Hence it is only necessary to ensure that the sample brought in is reasonably free from white, unripened seeds, and from impurities, before making payment.

A reasonable cost of collection is from 4d. to 8d. per lb., depending on the density of the crop. Where casual labour, such as gypsies, is engaged, it is as well to remember that chestnuts also have a sale value for eating purposes, and to ensure that no seed finds its way into other channels owing to the attraction of higher rates.

Storage

Chestnut is a difficult seed to store, and opinions differ as to the best method to adopt. It is important to remember that only good firm, well-ripened seed will keep at all, and to reject at the outset all defective nuts. Such nuts will not only fail to keep themselves, but they may also spread decay among the remainder. Another common cause of failure is lack of attention to the nuts just after collection. If they are kept too long in closed sacks, or piled in deep heaps, they are likely to heat up, and no amount of care thereafter will restore their lost germinative power. They should be brought at once to some central storage point and spread out thinly.

The following methods of storage have been found to give satisfactory results.

(a) **Stratification for six months in moist sand.** A stratification pit is prepared as described for alder on page 20.

The seed should be mixed by hand, with an adequate quantity of slightly moist sand, so that each chestnut is separated from its neighbours by a sandy layer. The mixture is then placed in the pit, and needs no further attention until the following spring, though an occasional inspection is advisable to make sure that it is keeping in good condition. In spring, inspections should be made at weekly intervals, and when it becomes evident, through the swelling of the seed and the emergence of root tips, that germination is about to begin, the seed should be removed from the pit and sown in the nursery bed. The surplus

sand should be removed prior to sowing, but no attempt should be made to secure perfectly clean seed.

(b) **Dry storage.** After collection, the seed should be spread out thinly to dry for a week or ten days, and then be stored in a cool shed which has been made both mouse-proof and bird-proof. The shed should be open to ordinary climatic changes, but it is as well to place a layer of well-dried bracken litter over the seed to protect it from frost. Conditions should not be too dry, as the seed tends to shrivel; a cellar has been found suitable.

(c) **Storage on Netting Trays.** Immediately after collection, the seeds are laid on trays of fine-mesh wire netting, being spaced so that they do not quite touch one another. This espacement prevents any heating up, and lessens the risk of spread of decay. The trays are kept in a cool mouse-proof place until the spring.

Whatever method of storage is adopted, sowing should be done fairly early, about March; it is difficult to keep the seed in good condition for a longer period.

Autumn Sowing

Although chestnuts germinate satisfactorily if sown in the autumn, this method cannot be recommended owing to the very high losses that are normally experienced through attacks by mice and birds.

Miscellaneous Data

Number of seeds per lb.	100
Normal percentage germination	60%
Weight of clean seed per 100 square yards of nursery bed	100 lb.
Number of square yards of nursery bed per lb. of seed	One
Date of sowing	March
Depth of covering	One inch of nursery soil

HORSE CHESTNUT

The horse chestnut, *Aesculus hippocastanum* L., is very seldom planted as a timber producing tree. Where it is required for ornamental planting, the methods of collection and storage of its seed may follow those recommended for sweet chestnut. Fertile seed is ripened in most parts of Britain in practically every autumn. Autumn sowing has given good results, as the horse chestnut seed is much less attractive to birds and rodents than is the seed of the sweet chestnut. The seed is generally larger than that of sweet chestnut, and as the seedlings are exceptionally big it should be sown more thinly.

HORNBEAM

The native hornbeam, *Carpinus betulus* L., produces ample seed nearly every year, and as only a small quantity is usually wanted, collection should be restricted to selected trees of good form. If the seed is gathered in the green state, and sown at once, it will germinate in the following spring; but if it is allowed to become fully ripe and brown before picking, it is necessary to stratify it for about fifteen months before it will germinate.

Collection

Hornbeam seed is gathered by hand from the growing tree. Green seed for immediate sowing is gathered when fully developed, and about to turn brown, in August or September. Ripe seed for stratifying should be left on the tree until late November or December, by which time both the seed and the bracts will have become quite brown. Only good plump seed, about the size of a small pea, should be picked, and cut tests should be made on samples to ensure that the kernel is sound.

Cleaning

This is best done in the course of hand picking, the seeds being separated from the leafy bracts.

Storage

Green seed requires no storage, but must be sown at once. Ripe seed should be mixed with an equal quantity of clean sharp sand and stored in a stratifying pit (as described for ash in Leaflet No. 33, entitled *Collection and Storage of Ash, Sycamore and Maple Seed*. H.M.S.O. 6d.) for about fifteen months. It should be taken from the pit in late March or early April, and sown in the nursery bed, together with the sand. Germination is slow and variable, 10,000 clean seeds go to the pound.

PLANE

The plane tree, *Platanus acerifolia* Willd. and allied species, ripens viable seed in most seasons in the south of England. The whole seed cluster, or seed ball, should be gathered when fully ripe, about midwinter. The individual seeds are separated from the central stalk by light rubbing with the hands; the fine hairs that surround them may be removed by rubbing the seed on a fine sieve, but this second process is not essential. The seeds should be sown in spring on a bed kept moist by frequent light watering. As an alternative to dry storage, the seed may be mixed with moist sand and stratified in a shallow pit (as described for ash in Leaflet No. 33) from midwinter until March; the seed is then sown still mixed with the sand. In either case, the seed should only be covered lightly, using not more than one-eighth of an inch of soil; or the seed may simply be pressed into the soil with the back of a spade. About 200,000 cleaned seeds go to the pound. Germination is somewhat irregular, and on an average only 35 per cent of seed sown may be expected to germinate.

POPLARS

All the poplars except the aspen are usually raised from cuttings or sets, and details of their propagation by that method will be found in Forestry Commission Leaflet No. 27, entitled *Poplar Planting* (H.M.S.O. 1s. 3d.).

The aspen, *Populus tremula* L., cannot easily be increased by means of cuttings, and is therefore raised from seed. A detailed description of the method recommended will be found in Forest Records No. 2, entitled *The Raising of Aspen from Seed* (H.M.S.O. 1s.). In brief, the procedure is to collect the catkins just as they open and are about to release the downy seeds, which normally happens in May. The seed is then separated from its downy covering, or pappus, by putting it into a paper bag, and blowing into the bag. It cannot be stored without loss of germinative power. It must be sown at once on a nursery bed with a very fine tilth, being lightly pressed into the soil, but not covered in any way. The bed must be lightly and carefully watered for several days and shaded

for the first few weeks. It is advisable to remove the pappus before sowing as otherwise the seed tends to be blown away. One pound of cleaned seed contains about 3,500,000 separate seeds.

If it is desired to raise poplars of other species from seed, the same procedure should be followed; but most of the kinds recommended for planting are hybrids, and are unlikely to come true from seed.

ROWAN

Seed of the rowan, *Sorbus aucuparia* L., is occasionally required for raising trees for ornamental planting. The fruit ripens in August in the south of England and in September further north. Ripeness is easily judged by the change of colour from green to orange or scarlet, together with the attacks on the fruit made by the birds as soon as it becomes ripe. Collection of the fruit from the tree can easily be done by hand, at a cost of a few pence per pound.

Cleaning and Storage

Good results have been obtained by cleaning the seed from the pulp immediately after collection. The fruits are placed in water and crushed by hand, and the seed is then separated with the aid of a culinary sieve. The separated seed is then stratified in moist sand until the following spring, when it gives excellent germination.

An alternative method is to leave the seeds in the fruit, stratifying the latter whole. But if this is done the fruit must be left in the stratifying pit for eighteen months before it will germinate.

One lb. of fruit holds about 2,400 seeds; one lb. of cleaned seed consists of about 130,000 grains. Germination may be as high as 80 per cent.

WALNUT

The common walnut, *Juglans regia* L., frequently ripens fertile seed in the south of England, but that grown further north is less satisfactory. The nuts are gathered as they ripen and become brown, from September onwards, and prompt collection is important, as many are taken by rooks and other birds. They may be picked from the tree, with the aid of ladders, long sticks, or long-handled clippers, or else picked up off the ground. Collection costs about 9d. per lb. and a good open-grown tree will yield as much as 25 lb. of nuts; empty nuts can be detected by their light weight, and should be rejected. The most satisfactory method of storage is probably stratification in sand for six months. Germination is irregular; some growers crack the nuts before sowing.

WHITEBEAM

The berries and seed of the whitebeam, *Sorbus aria* Crantz., and its several varieties, should be collected and treated in the same way as those of the rowan. As with the rowan, seed stratified without extraction from the fruit must be left for eighteen months before it will germinate.

One pound of whitebeam fruit contains about 650 seeds.

WILLOWS

As with the poplars, willows of the genus *Salix* are almost invariably increased by cuttings. If it is desired to raise them from seed, this must be gathered as soon as the catkins open, normally in May or June. The seed cannot

be stored, but must be sown at once; it should be treated in the same way as aspen, as described on page 28.

For the propagation of willows by cuttings or sets, see Forestry Commission Bulletin 17, *The Cultivation of the Cricket Bat Willow*. Revised 1958 (H.M.S.O. 5s.).

UNDERCUTTING OF CONIFER SEEDLINGS

By S. M. PETRIE

Divisional Officer, East Scotland

In the East Conservancy, Scotland, an experiment was laid down in F.Y.54 to compare the survival rate, expressed as a percentage, of 1-undercut-1 plants against 1+1 transplants of the same species and origin, planted under the same conditions. Normal planting technique was adopted. It was further desired to assess any differences in the rate of growth of 1-undercut-1 and 1+1 plants.

The number of plants per plot varied from 200 to 3,000. Plots of each type of plant were adjacent to each other and received exactly similar treatment. According to site they were either planted direct or on ploughed ground, manured or unmanured. Species used in the trials were Scots pine, European larch, hybrid larch and Japanese larch.

In 1951, the Forester at Ledmore Nursery began some trial work on sowing seed by mechanical means with the intention of undercutting. The idea was to produce a strong usable plant cheaply and to avoid the losses in transplanting—stripping of roots and exposure of roots to drying winds.

After various trials, he came to the conclusion that May was the best month of the year for the operation, that is when shoot and root growth were most active. Once a root system is disturbed the natural reaction is to gain a fresh hold and this is apparently most easily done when the plant is in full vigour of growth. The undercutting is considered best done at a depth of from 3 to 4 inches. (This rule may not necessarily apply to the undercutting of broad-leaved trees.) During the process of re-establishment of the root system, there was a distinct tendency for the plant to put out very strong lateral roots; this type of root system was not the one being sought. A type similar to the transplanted seedling's, a ball or mat of fibrous roots for convenience of planting and quick establishment was what was being aimed at.

Such a root system was obtained by the side cutting of the roots, an operation performed two months or so after the undercutting. In Ledmore, the undercut plants seem generally to have a slight lead over the transplants in height growth at the end of the growing season.

The experiments, using the two types of plant, were set out at nine forests in the Conservancy; assessments have been done annually for the five years since planting and results in every case have shown that there is no significant difference either in rate of survival or rate of growth in all species in all plots. Results indicate that there should be no fear in using satisfactorily undercut plants, of the species named, in place of the normal transplant of the same age.

AFFORESTATION OF OPEN-CAST COAL WORKINGS AT ABERPERGWM, COED MORGANNWG

By JOHN WHITE

District Officer, South Wales

The site was worked for coal between 1948 and 1953 and was handed back to the Forestry Commission on 1.1.54.

The specification for restoration included the following terms:—

(1) Restoration of top soil or original contours not required; in general the "hill and dale" layout to be accepted.

(2) No slopes to be steeper than 1 in 2 (27°).

(3) No slope to exceed 200 ft. without terracing. Terraces to form tracks 14 ft. wide and not steeper than 1 in 7. Tracks of same specification to be formed in the "dales".

(4) The area to be made self draining and all "ponding" avoided by suitable alteration of contours by dozing.

This particular area was planted with a variety of species with the object of providing some information on the subject for extended work in the future on similar sites in the vicinity.

It is pretty well established that Corsican pine is a reliable species for planting on colliery waste heaps and lest too many failures should occur the other species were planted in mixture with Corsican pine as well as in pure patches. The list of species used is as follows:—

Scots pine	<i>Abies nobilis</i>	Birch
Corsican pine	Western hemlock	Alder
Lodgepole pine	Western red cedar]	Grey alder
Japanese larch	Lawson cypress	Robinia
Norway spruce	Red oak	Mountain ash
Sitka spruce	Sycamore	

In addition to trees, lupin and broom seed were sown in places with the object of increasing the nitrogenous content of the soil.

Part of the area was also treated with Potassic Superphosphate (Fisons No. 7) at the rate of 2 oz. per tree.

Most of the planting (25.2 acres) was done in 1954, although a very small amount of broom seed was sown in 1953. A further 1.8 acres was planted in P.55 and the P.54 area was beaten up. In order to give a quick cover a spacing of 4 ft. × 4 ft. was adopted throughout.

Scots pine was introduced as seed. In addition to the specimen plot a few surplus seed were used up in other plots.

Natural sallow birch and sycamore have made their appearance in addition to grass and weeds.

Establishment has been remarkably successful. The *Abies nobilis* are particularly outstanding and nowhere else in Coed Morgannwg have they taken so well. Alder and some of the Robinia have also grown very well. In

general, failures occur only where the slopes are so steep that the soil has not yet reached the natural angle of repose. The plants on the side slopes appear to be growing rather better than those on the level areas which may have been somewhat compacted by heavy machines passing over them.

It is interesting to note that the lines where the lupin was sown are now marked by lines of weed growth. Whether this is due to the manurial effect of the lupin crop, or is due to the raking together of soil (and weed seed in it) in the process of sowing, it is not possible to say.

FOEL FYNYDDAU

A MOUNTAIN STERILISED BY OLD COPPER WORKS

By JOHN WHITE

District Officer, South Wales

The peculiarly sterile nature of this mountain top has undoubtedly been caused by the activities of the now defunct Rio Tinto Copper Works. These were situated at the base of the mountain in the village of Cwmavon. It is understood they started operations about 1800 and closed down about 1910. It appears that the site of the works was chosen so that the fumes could be carried a considerable distance away by a flue which was laid up the mountain side and terminated in a stack on the mountain top. It is claimed locally that this flue was exactly a mile long, but the map measurement shows it to be about 1,000 yards. The vertical rise is about 1,000 ft. and gives rise to the claim that the flue and stack constituted the tallest chimney ever known. The stack was demolished during the Hitler war as it was feared it might be used as a landmark by enemy bombers.

It is related that some time in the last century, probably about 1880 or a little earlier, the surrounding farmers brought an action against the Copper Company claiming that their animals were being poisoned by the copper fumes and deposits. It appears that a settlement was reached whereby the Company took over the tenancy of these farms and sublet them to the farmers at a reduced rental. It does not seem that any human beings were injured by the fumes, but it is said that the workmen were easily recognisable by a green tint in their hair and beards!

The effect of destroying the vegetation, thus causing consequent soil erosion on the mountain top, is most striking, but it is a little puzzling that this sterility should extend more or less uniformly all round the stack and not be more marked in the path of the prevailing wind.

It is now 40 to 50 years since the works stopped operating and there are signs that vegetation is slowly creeping back. On a recent acquisition inspection, natural seedlings of Scots pine and rhododendron were found. The east and north slopes of the mountain are being considered for acquisition.

THE DEVELOPMENT OF RADIO COMMUNICATIONS IN THE FORESTRY COMMISSION

By C. A. CONNELL

Conservator, South-West England

Part I

In the general impetus given by wartime experiences to post-war development of forest fire prevention, which started in 1946, it was inevitable that emphasis should be placed on the roles of water and communications in detecting and combating fires. The subject of supply, transportation and tactical delivery of water has been very adequately covered in post-war literature. The same cannot be said about communications in general and certainly not about radio in particular. In view of the fact that there are now 125 packsets and almost a score of mobiles distributed over both Deputy Surveyor charges and every Conservancy except one, it is felt that the history of this innovation should be recorded. Ere long radio equipment will be a commonplace item of Forest Stores and a new generation of forest staff will take it for granted, but they may well enquire why certain basic technicalities came to be standardised. This article attempts to give the answer.

Field tests were first carried out at Newcastleton Forest in 1946 through the courtesy of Scottish Command who sent a detachment of the Black Watch with walkie-talkies. The results were, not unexpectedly, inconclusive but encouraging and so further trials using War Department type portable and transportable gear were made in both England and Scotland over a period of some months. The results were such as to justify a serious appraisal in technical and economic terms of the desirability of the adoption of radio by the Commission.

About this time there came on the civilian market at low prices large quantities of ex-Services equipment, including the identical sets used in the above mentioned trials. The Purchasing Section at Headquarters, not unnaturally, considered that substantial economies could be effected by buying such gear, and indeed it would have been wonderful to equip all forests with, for instance, No. 18 sets at £5 each, but this was a case where technicalities conflicted with economics. The unhappy truth was that none of this gear, universally to be known as "Government surplus", was any good for civilian commercial purposes because of Post Office regulations, and even less so for Forestry Commission purposes because of the need to have equipment which could be used by forest workers without tuition in radio as such. The reader may well ask, then why was the gear put on the market anyway, and who would buy it? That it was all sold is a fact; much of it found its way overseas, some of it was converted by licensed amateurs at appreciable cost to comply with G.P.O. rules, and some was undoubtedly used in Great Britain exactly as bought, and therefore illegally. On this point it is worth while noting that as recently as October 1958 the Deputy Public Relations Officer of the G.P.O. found it necessary to publish a reminder as to the position. The relevant part of the letter is quoted:

"Any person who intends to use Government surplus transmission equipment must, therefore, obtain a licence. I am afraid that in the majority of cases the technical characteristics of the equipment, including the frequency bands in which it works, are such that the Postmaster General would not be able to grant one".

The G.P.O. is the statutory authority in Great Britain, controlling every aspect of radio communications and all users, except the fighting Services and the Civil Service; but even with the Armed Forces there is an accord, while in conformity with the principle well known to all Government Servants, the Civil Service abides by the rules of a constituent member, even though legally free to adopt an independent line. Thus for all practical purposes the Forestry Commission is in the same position as a private user of radio facilities, though no licence fees are paid.

By international agreement (the last Conference was at Atlantic City, U.S.A. in 1947) the G.P.O. allots different bands of the frequency spectrum to the various classes of user; the most popularly known of these are the Band I, Band II and Band III transmissions devoted to B.B.C. television, B.B.C. Frequency Modulated sound, and Independent Television respectively. Other bands well known in communications circles are those used by Police, Fire Brigade, Ambulance and other Home Office services (29.7 to 41.0 megacycles or Mcs.), by amateurs (14.0 to 14.35 Mcs.; 21.0 to 21.45 Mcs.; 28.0 to 29.7 Mcs.; 144 to 146 Mcs.; 1,215 to 1,300 Mcs.; 2,300 to 2,450 Mcs.; 5,650 to 5,850 Mcs. and 10,000 to 10,500 Mcs.), by international short-wave broadcasting stations (various, for example, 6.01 to 6.195 Mcs.; 9.41 to 9.915 Mcs.; 25.75 to 26.10 Mcs.) and by what are called, for want of a better description, business, commercial and private users (22.0 to 25.6 Mcs.; 68.0 to 87.5 Mcs.; 100 to 108 Mcs.; 146 to 174 Mcs. and 420 to 470 Mcs.). These last are shared frequencies, that is, more than one person or firm uses a frequency, relying on geographical separation or limitation of range to avoid mutual interference.

The G.P.O. in 1949 offered the Commission a frequency out of either the 68.0 to 87.5 Mcs. band or the 146 to 174 Mcs. band, both of which are in that part of the spectrum known as Very High Frequency, or V.H.F. Research work on the attenuation of signal strength through woodlands at V.H.F. carried out by Saxton and Lane (Radio Research Laboratory of the Department of Scientific and Industrial Research) showed that this was at a minimum, in fact, negligible, between 80 and 90 Mcs., but of serious consequence at higher frequencies. It was natural, therefore, to ask the G.P.O. for the first of the two alternatives and 86.475 Mcs. was allocated to the Forestry Commission. This is not an exclusive frequency, being shared with the British Transport Commission track-laying gangs, but was chosen because the two users were considered unlikely to be working the same areas. This has proved to be the case.

One basic technicality not controlled by the G.P.O. is the method of modulation, that is, the way in which intelligence is superimposed on the carrier wave which goes out at the quoted frequency. Due to the publicity given by the B.B.C. to its recently-introduced V.H.F. sound broadcasting service, most people are aware of Frequency Modulation (or F.M.) as applied to this service and know it is different from the Amplitude Modulation (or A.M.) of the medium and long waves broadcasting service which has been part and parcel of everyday life for the past 35 years. Before embarking on the purchase of even the small amount of gear for a pilot radio communications scheme, the fundamental decision had to be made—A.M. or F.M. equipment?

Once again the technical and economic aspects were likely to conflict. Theoretical technical considerations suggested that F.M. would be better for forest conditions; this was unlikely to please the Purchasing Section because whereas five firms marketed A.M. walkie-talkies and could be expected to quote competitively keen prices, only one firm produced F.M. packsets. Obviously, the technical arguments in favour of F.M. would have to be very strong to overcome financial bias towards A.M. Nothing short of full scale field trials

was likely to give the answer, preferably in the form of immediate comparisons made on the different types of equipment side by side.

By this time it was known in the Trade that the Forestry Commission was a potential customer for V.H.F. equipment, even though in modest quantities, so there was no difficulty in arranging for a complete installation to be borrowed entirely free of charge for some months. Thetford Chase was chosen as the operational forest and in 1953 A.M. gear was used in day-to-day forest management for some months; this was followed by a similar period when F.M. gear from a different manufacturer was tried out. At one stage it proved possible to have personnel with an A.M. packset on one shoulder and an F.M. packset on the other shoulder. Every message was sent by A.M. and then instantly repeated by F.M.

Throughout, the superiority of F.M. was manifest and accorded with the results obtained in other Forest Services throughout the world, the majority of which had either always used F.M. or were rapidly switching over to it as original A.M. gear called for replacement. While in the U.S.A. in the Autumn of 1951, the writer made a special point of studying the radio communications set-up in the North-West Rocky Mountains Region of the U.S. Forest Service. Three million dollars worth of equipment was in daily use and experience was available from the early 1930's. The professional staff were unanimous in recommending F.M., to which they had turned from the time F.M. gear had become commercially available.

The main attractive features in theory, borne out in practice, which F.M. conferred on radio for forestry use were slightly greater range, a more constant signal in the service area with pronounced cut-off at the limit of that area, a much improved signal-to-noise ratio, and the opportunity to design smaller but more efficient transmitters which, in terms of the finished article, meant smaller and lighter sets with reduced current consumption. The die was therefore cast for Frequency Modulation.

For many years there have been certain basic features of design on which the G.P.O. has insisted, and still insists, as far as business, commercial and private licensees in the V.H.F. bands are concerned. These are that the transmitter shall not have variable tuning, shall operate only on a pre-allotted frequency or frequencies, shall be crystal controlled to avoid any drift off frequency and shall be limited as to aerial output in terms of watts. While these rules sound rather arbitrary it must be admitted that they are undoubtedly essential; without them there would soon be chaotic conditions in radio traffic, ending in a relatively few users with inordinately powerful transmitters "hogging" the entire band. The freedom and ease with which thousands and thousands of business licensees use their daily radio links within the narrow band widths of a few megacycles earlier detailed provides an irrefutable answer to those who proclaim the G.P.O. attitude harsh and bureaucratic.

To return to the Forestry Commission problem of whether "Government surplus" or new civilian equipment should be bought, we can now see that a choice never really arose. The "surplus" gear of the size required had variable tuning, could be used on a wide range of frequencies at will, had no crystal control, was set up for H.F. and not V.H.F., and was Amplitude Modulated. It was, therefore, "out" on every count.

With the decision to adopt radio, to buy new civilian equipment and to standardize on F.M. in the V.H.F. part of the spectrum, the stage was set for the incorporation of radio communication into the Fire Plan of an F. C. forest.

Part II

In June 1954 the first installation was bought from the General Electric Company Limited, and commissioned at Santon Downham to serve Thetford Chase, and surrounding areas such as Swaffham and Kings Forests. The price was £740, which covered a main station with remote control, two mobiles in Land-Rovers, and two packsets. A word of explanation about remote control for main stations may not be out of place. The transmitter/receiver (standard abbreviation Tx/Rx) is installed at the bottom or the top of a tower which may be a fire tower or simply a device to elevate the aerial to the maximum practicable and economic height. The microphone and loudspeaker, which latter together with the switch for changing from "transmit" to "receive" and the master switch which turns the entire apparatus ON and OFF are housed in a small console, can be up to 10 miles away from the Tx/Rx, thus permitting operation in a District Forest office with radiation from the highest point in the locality to ensure the largest service area. Of course, there are two desirable (but not now essential) requirements when selecting a main station site, A.C. mains and G.P.O. telephone line. The former is needed to power the installation and the latter to provide the remote control circuit. At Santon Downham the Tx/Rx is at ground level, the aerial is on a guyed mast, and control is from the District Office some 500 yards away.

Following on satisfactory reports from Conservator, East England, attention was then focussed on the New Forest, for long bedevilled by fire problems arising from nation-wide popularity of the Forest as a tourist centre. Signal strength tests, carried out over the whole of the territory under the Deputy Surveyor's jurisdiction, indicated the fire tower at Fritham as the ideal site for the main station. Unfortunately there was no electricity available within an economic distance, so the second-best choice was accepted, the Emery Down fire tower, some 50 feet lower in elevation. As events turned out, the Emery Down tower, with its aerial 370 feet above sea level, proved entirely satisfactory, permitting the set installed in the cabin at the top to radiate a good signal over the entire administrative area, not excluding the Isle of Wight. This main station, remotely controlled from either the Deputy Surveyor's office or the Forest Fire Control Centre, was supported by two mobiles and six packsets in the New Forest proper, with one mobile at Ringwood Forest. Local enthusiasm and ingenuity soon revealed themselves, and many lorries, vans and Foresters' vehicles were fitted with simple aerials, thus permitting use of the packsets as transportables. For instance, with a packset installed in the cab, a Mobile Dam unit would rumble off to a fire, report to Fire Control on arrival, and move into tactical fighting position on radio orders. One of the personnel aboard would then uncouple the packset from the M.D.U's aerial, swing it on to his back with telescopic aerial extended, and move off on foot, still in communication with Fire Control. This sort of versatility of use of the radio equipment brought new enthusiasm to all concerned with forest fire fighting there, and the Deputy Surveyor was soon reporting speedier attack, fewer abortive turn-outs, and reduced losses, all solely due to the impact of radio communications on his Fire Plan.

The next territory considered to qualify for a radio system was the North Yorkshire moors area of Conservancy North-East England, more widely known, perhaps, under the forest names of Allerston and Cleveland. Here a main station was installed mid-Summer 1955 in the Jingleby, Allerston, fire tower which occupied the most advantageous position on the whole of the moors, and it was linked to a remote control in the Head Forester's office at Low Dalby. The intention was (and still is) to have control also from the District

Office in Pickering, but the G.P.O. has been unable to provide the remote control circuit, and intimates that it will be unable to do so until a new underground cable for general public traffic is laid, a project involving considerable capital expenditure and, therefore, having a low priority.

The remainder of the scheme comprised three mobiles and six packsets, the former being allotted to the Allerston and Cleveland District Officers respectively and to the Allerston Head Forester. The installation remained at this strength until 1958 when two packsets were added, these eight in all now being grouped on an *ad hoc* basis as required for management and protection purposes.

Within a short time from commissioning, the installation proved its value and very appreciably reduced the fire tension, and the incidence of frayed nerves among the staff, particularly at Newton Dale, probably at that time the unit with the greatest fire danger in the Conservancy. Considerable progress was also made here in the development of day-to-day radio use for routine forest management. For instance, the mobile mechanist used a packset as a transportable set in his van and during the months when the ploughing "circus" was working flat-out on remote parts of the moor, the ability of the mechanist to deal with breakdowns in tractors and ploughs more quickly, and to order spares without leaving a crippled machine on which he was working, materially influenced both the cost per acre of ploughing and the standing charges per hour for the tractors. As a footnote to this brief account of the Jingleby station, and for purely historical reference, it is of interest to know that the very first signal received on switching on the main station was Thetford Chase traffic. Transmissions from the main station at Santon Downham, 143 miles away, came through loud and clear, but there was no link the reverse way. Conditions were, of course, freakish but have been repeated once or twice since under similar meteorological circumstances.

In the Spring of 1956 the first Scheme was inaugurated in Scotland, at Culbin. Here a main station was sited in the Head Forester's office, directly controlled, and was supported by one mobile and four packsets. The aerial was mounted on a pole and gave good coverage of all the forest on the link main-to-mobile. From many points, and fortunately most of the danger spots were included, direct contact between main station and packsets was good and reliable too.

These four major installations comprised what might be termed the full scale field trial units, and their successful establishment and working paved the way and provided the justification for developing radio inside the Forestry Commission on a more or less routine basis. This period in our story finished at the end of F.Y.56.

Part III

Early in F.Y.57 the Technical Committee considered a report on progress made and results achieved and decided that radio should be introduced into many of the larger forests in all three Directorates where fire is still a major danger. As a result an order was placed for 100 packsets, delivery to be effected from January 1958 onwards. All Conservancies except one participated in the share-out which was completed by Whitsuntide 1958. In a few cases a Land-Rover mobile was added to the packsets.

Development on this scale at once raised three important issues, additional frequencies, callsigns and technical staff.

All the Forestry Commission installations work on the system known as single frequency simplex, one of three possible systems, and the one giving complete flexibility. Its one disadvantage is that if two forests are within the service area of the sets, each hears the traffic of the other, and this can be not only annoying but a downright nuisance. Efforts were, therefore, made to obtain two more frequencies. Unfortunately, the G.P.O. could not see its way to allot two, but one was granted, being 86.425 megacycles. Since that time the frequency allotment has been most carefully worked out for each forest, to try and avoid inter-forest interference and interference from and with other users of the same frequencies. Inter-forest interference has not in every case been eliminated and a definite need still exists for a third frequency, but there is no prospect at the time of writing of getting this. In Forestry Commission circles the original frequency of 86.475 Mcs. is known as Channel 1 and the second frequency, 86.425 Mcs., as Channel 2.

Discussions were opened with the G.P.O. also on uniformity of callsigns. A callsign is necessary (and obligatory) for every transmitting installation, primarily to help the G.P.O. in its statutory duty of tracing interference. It also, obviously, is highly desirable for identification purposes within the organisation of the user. It was agreed that the basic callsign for the Commission should be FIRE, and that geographical identification should be achieved by a prefix taken from the name of the forest or, occasionally, from the name of the location of the main station. Examples of each are Warefire for Wareham Forest, and Sanfire for Thetford Chase, the main station being at Santon Downham. A list of approved callsigns as at time of writing is given at the end of this article. Individual identification within a forest is catered for by giving each set a name from a universally known and accepted list based on a phonetic alphabet. So we have Warefire Charlie, Sanfire Baker, and so on.

The amount of equipment in use throughout the Commission in 1958 and the need for its efficient maintenance, coupled with the provision of a technical advice bureau which ever-mounting enthusiasm among field staff demanded, produced a pressing demand for the appointment of a full-time radio technician. The Commissioners approved the idea and in August 1958 a Forester with some 30 years' experience of radio as a hobby was seconded to the new post. The appointment of someone who possessed 20 years' experience of forest management and fire protection instead of a person from the radio world and outside the Service has proved gratifying to the field staff, since they find in their radio mentor a man who speaks fluently their own forestry language. The new staff was supplied with a Land-Rover completely equipped with a 2-channel mobile set, all necessary test gear to factory standards, spare packsets, and the usual run of tools for carrying out mechanical jobs such as aerial hook-ups, etc. In order to be fully *au fait* with the particular makers of equipment in use, the Radio Forester spent three weeks at the G.E.C. factory, Coventry, and a short period at the Cossor factory at Stanmore, Middlesex. Since Autumn 1958 to time of writing he has been visiting different Conservancies on a pre-arranged schedule, carrying out reconnaissances at Conservators' direction, checking the service given by maintenance contractors, helping Foresters and Officers to get the best from their sets, etc., and this will continue.

What of the future?

Already there is evidence that Conservators desire to augment existing installations with, for example, mobile and main stations, and to introduce radio at more Forests. From the calls being made on the Radio Forester's services it is clear that one of these days the complement will need to be doubled, and eventually trebled to provide adequate service in each Directorate. In the

technical realm there is exciting new equipment coming on the market, lighter, cheaper and of better design than has been available to date. Of greatest interest is the availability now of main stations powered from a small windmill, and controlled by a non-G.P.O. line. Freedom from dependence on A.C. mains opens up enormous scope in forests remote from the electricity grid. Is it too optimistic a forecast that by the time the five million acre programme for forestry has been achieved, there will be a Conservator (Communications)?

List of Forests and their Callsigns

The following Callsigns have been allotted by the G.P.O.:

<i>Name of Forest (or District)</i>	<i>Callsign</i>	<i>Channel</i>
Ae	Aefire	1
Allerston	Jinglefire	1
Bedgebury	Bedfire	1
Black Isle	Blackfire	2
Bramshill	Bramfire	1
Brechfa	Brechfire	(Not yet allocated)
Cleveland	Clefire	1
Coed Morgannwg	Glamfire	1
Culbin	Culfire	1
Dean	Deanfire	2
Dunster/Brendon	Brenfire	1
Glentrool	Glenfire	1
Haldon	Exefire	1
Halwill	Halfire	1
Kielder	Kiefire	1
Laughton	Lawfire	1
Leanachan	Leafire	1
Loch Ard	Lochfire	1
Minard	Minfire	1
New	Lynfire	1
Newtyle	Newfire	1
Pitfichie	Pitfire	2
Rendlesham	Renfire	2
Ringwood	Ringfire	1
Sherwood	Sherfire	1
Speymouth	Speyfire	2
Tentsmuir	Tentfire	1
Thetford	Sanfire	1
Wareham	Warefire	2

Channel 1 is 86.475 Mcs. Channel 2 is 86.425 Mcs.

WATER DAMS FOR FIRE FIGHTING

By J. W. ENGLAND

Assistant Forester, South Wales

The value of water for fighting forest fires is more fully and generally appreciated now that more plantations are coming into canopy, and mechanical equipment, both Forestry Commission and that belonging to the County Fire Services, is becoming more readily available. Roads too have made detection and communication easier. It is thus possible to call up water for fire fighting with more confidence than has hitherto been possible.

Strategically water supplies must be sited adjacent to good roads, and be of sufficient size for their inclusion in the Fire Plan to be worth while. They must be reliable, and both the location and the capacity must be clearly marked.

Tactically the use of water for fighting forest fires calls for new techniques and though the purpose of this article is not to discuss methods and rates of delivery of water to suppress forest fires in the older plantations, it is appreciated that a field exists in which a great deal of research remains to be done.

Much can be done to make the best possible use of the water available. Bearing in mind that a modern fire appliance can deal with 1,000 gallons of water per minute, a tank holding 100 gallons would scarcely fill the suction and delivery hose and maintain pressure. Whilst every little helps, it may well be that fire in the older plantations will be suppressed only by the use of water. With the assistance of powerful pumps, water can be carried considerable distances, also hose can be laid very rapidly along forest roads and rides.

In order to do this, some assurance must be available to the fire team that the time will not be wasted and that valuable equipment will not be endangered. The greatest assurance must come from an adequate supply of water, sufficiently large to enable the fire team to establish a foothold and at least check the rate of spread and the intensity of the flames.

County Fire Services would not hesitate to risk the loss of a few lengths of hose, but could not be expected to expose a costly appliance to risk, and as the whole precept of fire fighting by County and other services *is based on the use of water*, it is not surprising that this basic fact is not readily expressed by them nor is it generally appreciated by others.

It follows that large dams are needed and also that they should conform to certain minimum standards, especially in areas of high fire danger.

Situation. Adjacent to good roads and streams ensures that the greatest possible area is served, pumps are able to devote maximum power to the delivery hose rather than to the suction hose (the power lost to raising water to the pump can be considerable). Provided a good flow of water in all seasons is available the site need not be of clay.

Size. This need only be conditioned by the area to be served and the limitations of the site, but a minimum of 10,000 gallons should be aimed at. The capacity should be clearly stated.

Maintenance is a very important factor in keeping the water moving, stagnation is prevented and weed growth discouraged. To maintain the capacity of the dam, silt must be prevented or constantly removed. To assist in all these aims it is necessary to filter the water before storing and fit a stopcock to the inlet.

To construct the dam it is essential to provide for its limits to fall clear of the course of the existing stream. It is a waste of time and money to construct a barrier across the run of an existing stream, for the purpose of storing water.

Silting soon reduces the capacity and subsequent cleaning is almost impossible. It is preferable to partially arrest the flow of water, filter it and pipe it to the storage dam and then return it in a continuous process via an overflow to the stream. See Figure 5 for a suitable lay-out.

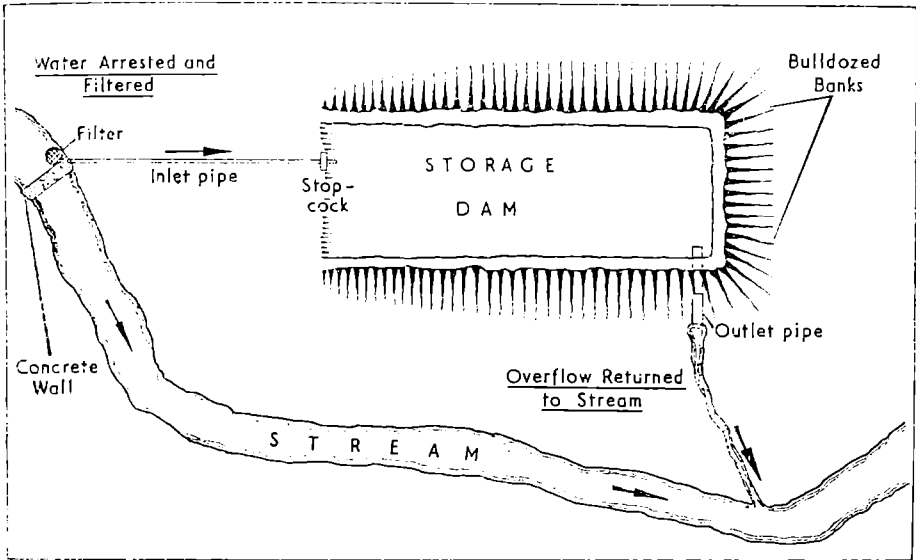

Fig. 5. Lay-out Plan for Water Dam.

Having selected a site—the ideal being at the junction of a good water course and a road, or where road and stream run a parallel course. A bulldozer following this plan can produce a dam of acceptable size in one full working day, plus half a day for tidying up.

(1) Clear top vegetation to lowest end of site.

(2) Produce the two long sides of the rectangle by removing evenly the layer of spoil exposed to each side of the site to a height not more than two feet above the ultimate level of the water. Top width is 6 inches wider than the tracks of the bulldozer, which should run along them to compact the banks and level them. These are now left undisturbed.

(3) Working from the highest end of the site to the lowest in long runs, the spoil is removed to the lowest end to form the third bank—each sweep should be made 2 to 3 inches further from the side banks towards the centre to form a batter. The lower bank is compacted and levelled. It is not necessary, except on completely level sites, to form a fourth bank.

This completes the first and main stage of the work.

The second stage consists of a simple concrete wall, 12 inches thick and 24 inches deep, set across the stream at a point slightly higher than the desired level of the water in the storage dam. A 36 inch diameter concrete pipe, cut through the middle, is set in one corner; and the pipe through which the storage dam will be supplied with water, is cemented into position, that is 6 inches below the brim of the concrete pipe and passing through the concrete wall. If the recessed end of the 36 inch concrete pipe is set uppermost, little difficulty will be encountered in fixing some strong $\frac{1}{2}$ inch wire mesh to form a lid, which is simply cut to size and placed inside the formed collar of the pipe. This forms the filter. (Fig. 6). The pipe through which the water is carried to the storage dam is fitted with a stopcock at the end which passes into the storage dam. (Fig. 7).

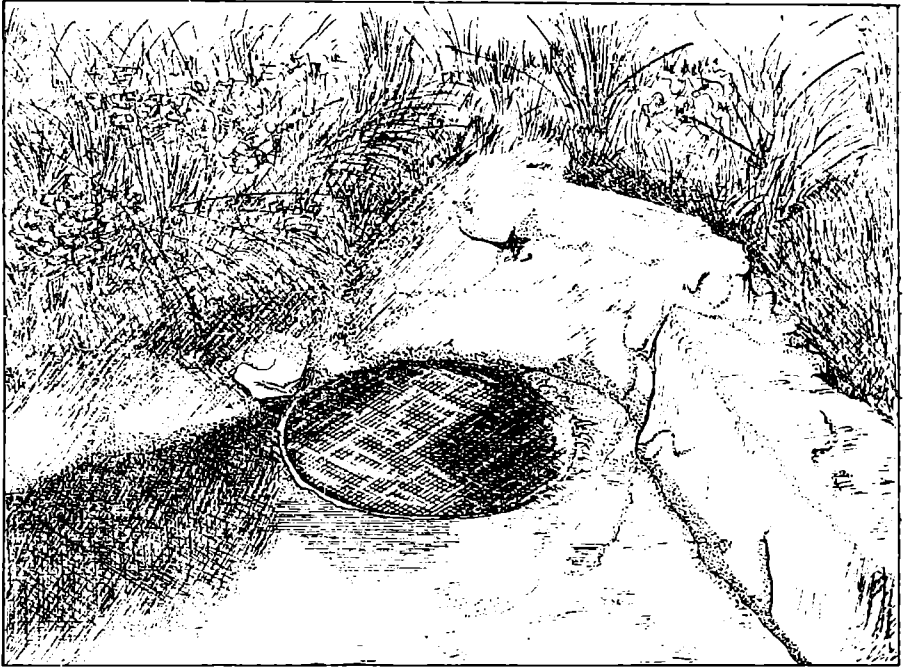

Fig. 6. Details of Inlet from Stream.

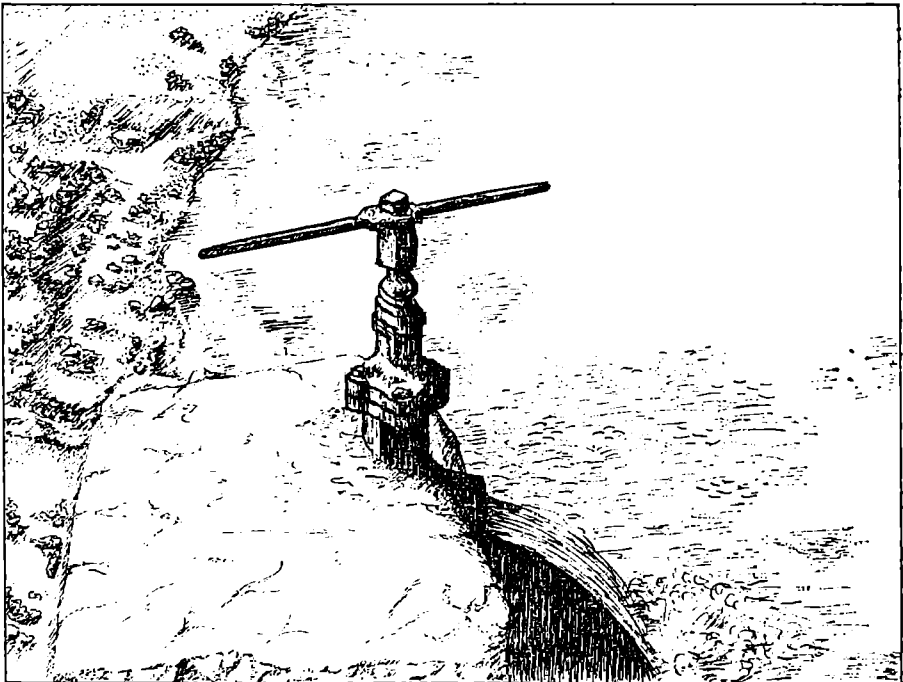

Fig. 7. Stop-cock on Outlet from Stream into Dam.

The overflow pipe should be twice the diameter of the inlet pipe and is set 12 inches below the rim of the dam at the deepest point and projects 3 feet into the dam and 3 feet beyond it; an overall length of 10 to 12 feet is desirable. The completed dam, filled with water, is illustrated in Figure 8.

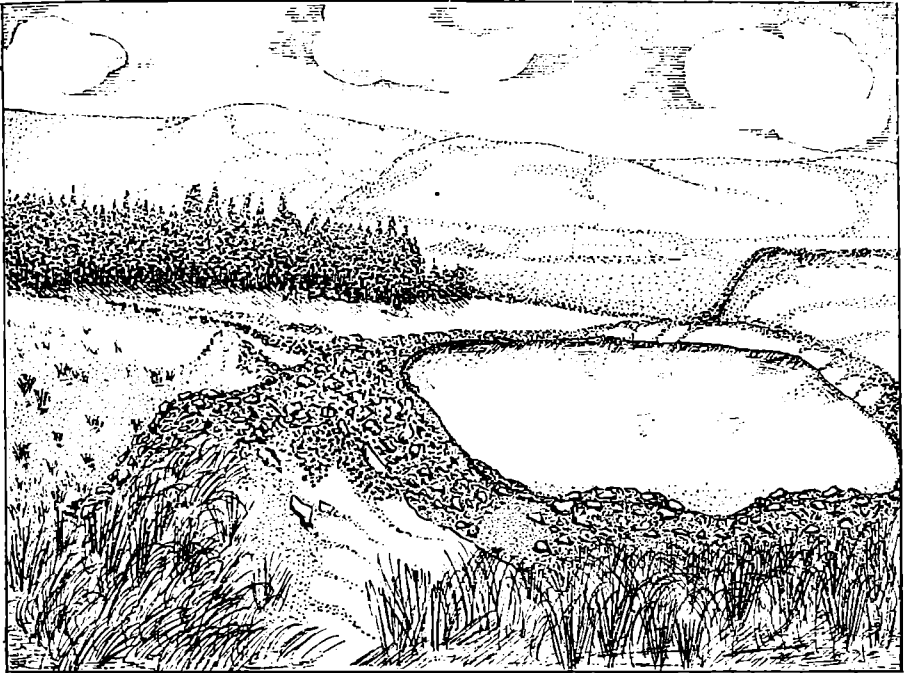

Fig. 8. General View of Water Dam.

WILD GOATS AT ABERGYNOLWYN, DOVEY FOREST

By J. R. HAMPSON

District Officer, North Wales

Over the past three years we have had minor trouble from a herd of semi-wild goats ranging the slopes of Cader Idris, which entered our Coed y Graig plantations (they are good jumpers!) and did a little browsing on the trees.

Wild goats were known here 35 to 45 years ago, when a little sporting shooting was done to control their numbers, but we have not wished to shoot them unless all other forms of discouragement failed.

In 1956, District Officer E. J. M. Davies reported: "Forester Hugh Jones has chased them (the goats) out with his dogs, and the old billy in charge of the marauders was given a good shaking up. It is not thought likely that he (the old billy, that is) will subject himself to this treatment again, or at least not for some time; particularly in front of his wives. A nanny goat was captured by Forester Jones in the foray. This hostage is now supplying him and his family with milk, until the goat is claimed by her owner. Thus life continues in our rural paradise".

Subsequently, a billy goat was also captured, but proved as offensive to Forester Jones's household by reason of its smell, as it had to the young plantations by its browsing, and it had to be released after some discouraging indignities!

A photograph, showing Forester Jones and his nanny goat appears in Central Inset, Plate 7.

OBSERVATIONS ON VOLE ATTACKS AT CHALLOCK AND LYMINGE FORESTS, EAST KENT

By D. A. MITHEN

District Officer, South-East England

The catastrophic type of vole damage one sometimes gets in recently planted areas is usually due to the Short-tailed Vole (*Microtus agrestis*). This species of vole is, however, responsible for damage on only one area at Challock Forest. This was on an area of some 25 acres of old parkland at the Sharsted block, which was completely ploughed prior to planting in P.56 with Douglas fir, tsgua and *Sequoia sempervirens*. The plants took extremely well in their first year but weed growth became well established by the first summer and by the summer of F.Y.57 the original dense grass mat, ideal harbourage for the short-tailed vole, was once more evident. Very heavy attacks by voles to the young plants occurred during the spring and summer of F.Y.57, damage being essentially gnawing of bark at the root collar with a large number completely girdled. All three species were attacked but sequoia least of all. To add to our misfortunes severe spring frosts occurred in late May/early June of that year. Thus, what looked like a most promising plantation at the end of F.Y.56 was a complete shambles at the end of F.Y.57. There has been a negligible amount of vole damage during F.Y.58 which is apparently not uncommon with the short-tailed vole—damage very rapidly reaching a peak and as quickly dropping off again.

The Bank Vole (*Clethrionomys glareolus*) on the other hand has been a source of trouble and anxiety over the past 9 to 10 years at both Challock and Lyminge. Apart from a small area of J.L., P.53, attacked during F.Y.56, beech has been the only species damaged.

It would seem that the beech is not attacked until it is older than about 8 years (i.e. when stems are about an inch or more in diameter). The attack continues until the crop has closed canopy (13-18 years of age)—no damage has occurred in beech plantations where the forest floor is clean. The thicket stage is the most vulnerable and it is possible that immediately after a coppice cleaning it is particularly so.

The damage consists of the gnawing of bark of both stem and branches up to 6 to 7 feet above ground level. At times the attack can be so severe as to completely girdle a stem 2 to 3 inches in diameter. Usually single trees or small groups of trees are attacked and it is not uncommon to find a tree extensively damaged with the one adjacent completely untouched. Damage occurs from April/May through to October/November and one can see the premature browning of the leaves in late summer on badly attacked trees. It is probable also that the voles attack the main roots. If only attacked by voles the vast bulk of the trees seem to recover, though obviously the ones completely girdled do die. This is evident at Lyminge where 9 to 10 years ago severe attacks by voles started on P.36-39 beech crops but now the only signs are the heavy callus tissue over the old wounds—the crops having closed canopy and cleaned the forest floor.

At Challock the picture is not quite the same. Here beech canker is also very much in evidence (it is also present at Lyminge but only on a limited scale). It would seem that the canker follows on the vole attack on a tree and what the vole started the canker finishes off, completely killing the tree. Like Lyminge many areas at Challock have shown complete recovery but one block of some 30 acres of P.39 beech has been so severely damaged that almost certainly it will require complete replanting.

Damage by the bank vole has continued on and off during most years with some years being very much worse than others. Experience over these years would seem to point out that during peak years of attack considerable anxiety can be felt for the well-being of a plantation but it usually recovers—provided beech canker is not also in evidence.

THE TRAINING OF BADGERS AT PERSHORE FOREST

By R. J. KING

Assistant Forester, South-West England

The Elmley Castle Block of Pershore Forest lies on the north-eastern escarpment of Bredon Hill, an outlier of the Cotswold Hills. Its composition is mostly of oolitic limestone giving rise to a light clay. The escarpment itself appears to be caused by a series of outcrops of 'marlstone' giving rise to a lighter clay, slight enough to support birch and gorse on the more exposed surfaces. (See Figure 9 for general lay-out of land.)

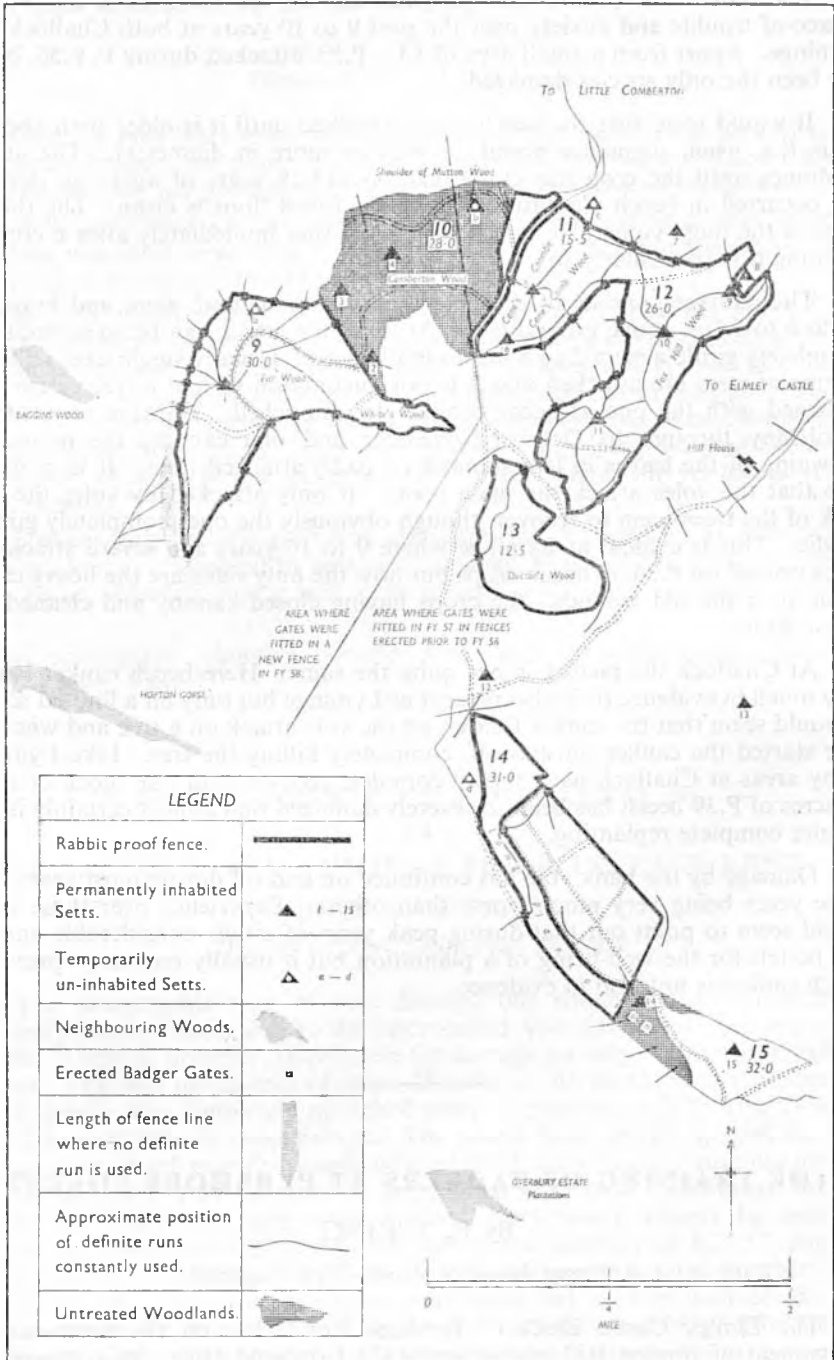

Fig. 9. Plan of Pershore Forest, Worcestershire, showing Positions of Fences, Badger Tracks, Badger Gates, Badger Setts, and Neighbouring Woods, as at 30th September, 1958.

Bredon Hill has long been famed for its dense population of badgers (*Meles meles*). The limestone and particularly the marlstone offer ideal soil conditions for the badger to burrow to form its sett. The British Mammal Society, in a survey in 1958, plotted over 200 setts over the eight square miles of the hill. Seventeen of these are inside the Forest boundary. Nearly the whole of this boundary is fenced against rabbits, which, alas, are now rapidly on the increase. Eventually the whole Forest will be rabbit fenced. The map shows the broken distribution of the woods and nearly each compartment requires to be fenced completely.

In 1957 with the threatened return of rabbits in even greater numbers, some remedy was needed as the badgers continually tore under or through the rabbit netting. This was needed to keep the rabbits out but allow the badger to have access to and from the plantations.

The badgers could not be controlled in any way, even if this was desired. Immigrants from other setts on the hill would soon repopulate any in which the usual residents had been exterminated. The only answer was to let the badgers have complete freedom but to introduce a swing gate where the run passed through the fence.

When the first fences at Pershore were erected in February 1954, the year planting began, I understand the trapper had a full-time job keeping clear of rabbits some thirty acres of new plantation, of $2\frac{1}{2}$, $12\frac{1}{2}$ and 15 acres, each surrounded by a fence. He would work the fences regularly to peg down where the badgers had torn through or under the night before. Just as regularly the badger would reopen the fence the next night.

After further fencing in February 1955, and even more tearing open and pegging down, the 99.9 per cent clearance of rabbits by myxomatosis reduced the anxiety altogether. The trapper tells me as many as 40 to 50 badger holes would appear in the fence line after a weekend during 1955.

During 1956, when rabbits were comparatively non-existent, the pegging down of gaps was discontinued and the badgers were able to settle down to regular undisturbed runs for 18 months. Once the definite runs were adopted by the badgers, there was little indiscriminate tearing open of fences. The map shows how the runs in Compartments 11, 12, 14 and 15 settled down. They have not changed much in two years.

A few points about the badger's habits could be mentioned here. Midwinter finds the badger in a deep sleep (not complete hibernation), only emerging from the sett on milder nights in search of food. The cubs are born in early spring. It is not until April that the runs become regularly used. Throughout the summer and autumn the badger is out and about, usually in one direction for a few nights, then another and so on. September/October is their most active season—not only are the young driven out of the parents' sett to reopen a "dormant" sett for themselves with a partner; (badgers usually pair for life), but the customary gathering of straw, dry grass, leaves, bracken etc. for the winter quarters happens during these months. This is naturally the time when the favour the badgers may show to unnatural looking swing gates is tested. At this time too weeding has quite likely caused confusion along the runs.

I have had most success when erecting gates during summer months when the badger goes out and about more, and does so with more confidence than in winter or spring. Usually new fences are erected in winter and so more careful work is called for when laying gates in a new fence line then. I find it takes 4 to 5 weeks to win badger's confidence with a new gate because so much care has to be used not to cause them to discontinue using a run—it may take them months

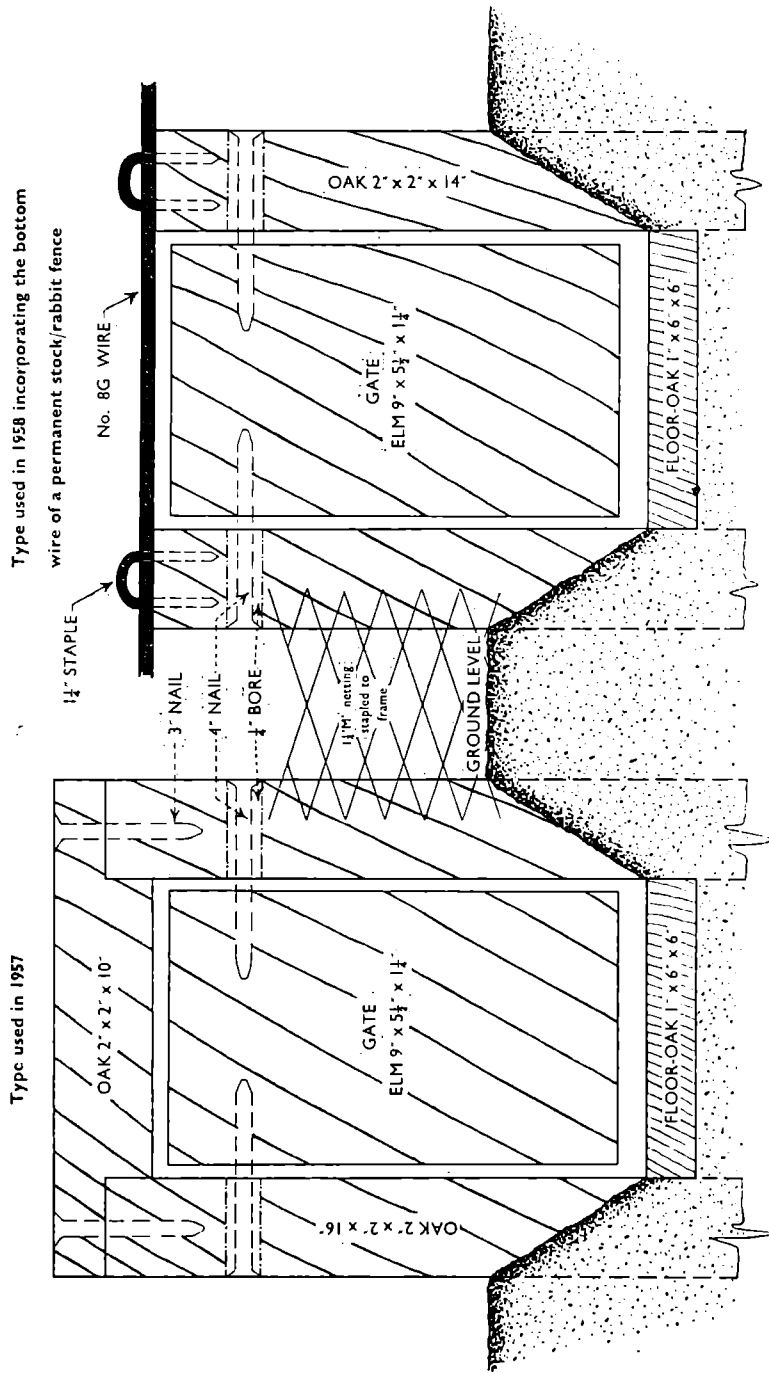

Fig. 10. Construction Diagrams for Two Types of Badger Gates, as seen in elevation.

to settle down to a new one before work can begin again on the newly adopted run.

In the spring of 1957, rabbits began to show their mark embarrassingly near the fences—in July they again found their way into the plantations through the holes in the fence caused by the badgers. If rabbits were to secure a hold again, as they are now doing, it was thought the quicker the badgers could be trained the better. The first gates were laid in August in Compartment 14.

The type used is detailed in the sketch attached. A solid elm board is better by far than the customary wood and netting door. On a neighbouring estate which tried this type the badger would often bite through the netting in the door! They have changed to one made of oak slats. Their theory is that the badger is more likely to be less put off if it can see through the gate—a point for thought. (See Figure 10 for types of gates.)

The fences erected prior to February 1958 had no bottom wire so a lintel was placed across the two uprights for rigidity. The gates were installed as follows. Assuming the run was constantly used, firstly the netting was cut neatly back and the gate then erected in careful stages. At each stage a pause of at least a week proved essential or the badgers would avoid the run and start elsewhere. The two uprights would then be driven in the ground, then a wait. Then the lintel and floor fitted, then a wait. The floor board is to stop the gap between the door and the ground from becoming worn and so allowing a rabbit to pass under. At first I tried fitting a full size door propped open for a week, then allowing it to fall shut. This proved too much for the cautious badger so I quickly removed the doors. I then tried fitting a gate half the size of the frame, again propped open for a week, after which it was allowed to fall shut, it only covered the top part of the gateway. This was the secret of getting a regular success with each gate. If all went well this was removed and a full gate fitted. In all, about 4 to 5 week's work, during which at any time rabbits can pass through and there is the likelihood of the badger becoming scared—avoiding the run and gate and taking several months to settle down to a new run. I found that once a run was no longer used by a certain family they would never take to it again, they would rather open new holes every night.

With confidence gained the fences around Compartments 11 and 12 were next treated, at first, it seemed, with no success. At about October of 1957 there were twenty gates at the half door stage, some being used some not, and as many holes being made in the fence each night. Then, for some reason for which I still don't know the answer, every gate was 'taken to' and only five 'escape' holes have occurred since. These were made during the weeding of Compartment 12, when the runs were disturbed in the bracken and perhaps the badgers became lost and tore their way out, since all were made from the inside. I now consider the badgers in the setts in this area "trained". They know what a gate is and will not be alarmed to find one fitted along another run they should use. In fact in November of 1957 two gates were fitted as an experiment in Compartment 13 in one stage and they were used the next night and have been ever since.

Badgers are known to change setts. Should this happen and a foreign family, unfamiliar with the gates arrive, I am not sure whether they will take to the runs and gates or not.

In 1958 Compartment 9 was to be planted, requiring 98 chain of fence crossing 22 runs, 18 regularly used, radiating mostly from sett No. 1, which covers 3 square chains and has 32 entrance and exit holes. The fence of stock rabbit pattern was done in January—at the time badgers rarely come out.

The fence had a bottom wire about 4 to 6 inches above the ground. Where the run crossed the fence the wire-netting was cut above the bottom wire and the ground earthed up like a ramp either side. The badgers when they came out seemed to favour this. The half door stage was reached with little trouble and a new hole would seldom appear in the fence. As soon as the full door was fitted in late February the badgers refused them and not one was used again. I think it was because the door struck the underside of the nostril, rather than the top of the nose as happens when the gate is partly below ground level.

Two months' work was in vain and for two more months the badgers refused to settle down to regular runs. In March the gates were taken out and the badgers could go where they wished.

In May the seldom-used runs were pegged down and smeared with bone oil—this proved most successful (also diesel and tar). Some 16 holes were left open and neatly cut back. Gradually the whole process was repeated, this time deepening the run under the bottom wire gradually to give room for a gate to be fitted. This proved difficult since the badger seems to fight shy very quickly when the soil of the run is disturbed unduly. In June/July the gates were erected again in stages—smearing all the rest of the wire more than 20 feet from the gates with bone oil.

By August everything was going well until weeding started, (mostly willow herb, sedges and bramble). Then the runs became buried, the badgers got lost and they would tear open the fence at will. But with careful clearing of the runs, re-application of bone oil, regular morning walking of the fences, the gates are being used with little trouble apart from about ten chains in the south-west corner.

The south-west corner is awkward because the fence crosses what appears to be a cubs' playground (and has been for years I'm told) and even with animal repellent aids the badgers will not use a regular run. I think the remedy will have to be deeply buried stronger wire with as many obstacles such as buried barb thorn branches and holly leaves as possible. There are rabbits on the outside and Japanese larch/ash on the inside!

In February 1959 Compartment 10 will be treated and the fence along the north-western boundary completed. With two years' knowledge it is hoped to have more constant successes. Bone oil and "Arikel" animal repellents will be smeared on the fence as it is erected except in the vicinity of a run. Also more care must be used when weeding is carried out, so as not to bury the runs, but to leave weeding a yard either side.

Undoubtedly patience and care are essential in this work, otherwise weeks of effort may be wasted. Of course a knowledge of the animals' habits, likes and dislikes, etc. is essential. Two efforts this summer at a nocturnal vigil have ended, however, in a good wetting without even a sight of one.

I am confident that a rabbit will not use a gate. The marks of rabbits can be seen running along the fence straight over a badger run which passes through a gate.

Food for further thought is the fact that in three places in Compartment 9 where the run passes alongside the fence (which is leaning slightly outwards) the badgers will scramble up the netting and over the top leaving a tuft of black and white hair in the top barbwire! Perhaps badgers can be trained to go over a three feet high fence rather than under it?

THE FELLING OF THINNINGS

By R. E. CROWTHER

Work Study Section

(1). Introduction

This is a record of observations made by members of Forestry Commission Work Study Section on fellers in various parts of the country; few fellers have all techniques perfect although some have parts of their technique excellent. By giving these good techniques wider publicity, improvement of the less effective workers can be achieved.

**FELLING DIRECTION ON STEEP SLOPES
ROWS RUNNING UP AND DOWN SLOPE**

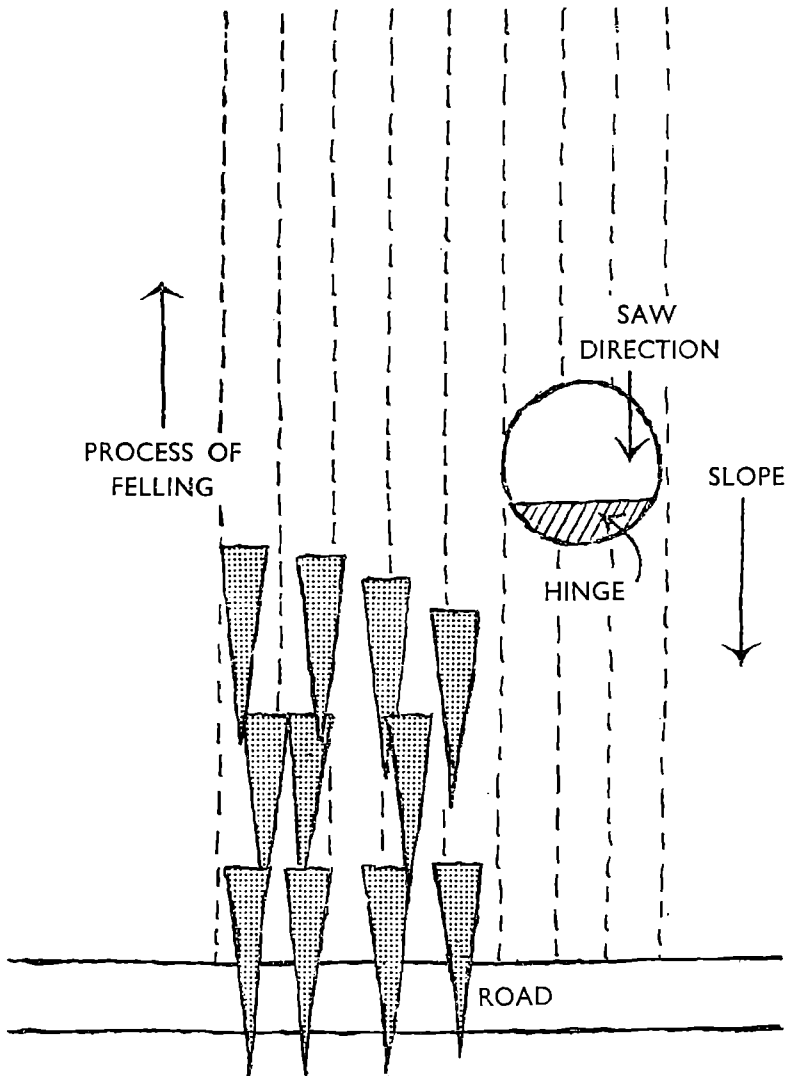

Fig. 11. Lay-out for Thinning Operations on a Steep Slope.

(2). **Organisation of the Thinning as a Whole**

The feller can improve his output by adopting good techniques but overall output can also be improved by proper arrangement of his work which is a matter of policy decided by the forest staff. Each operation should leave the poles in the best situation for the succeeding one. For example, in felling it is most important that the poles should be laid in the direction that will best suit extraction, as a pole once felled is extremely difficult to turn, and this will add to extraction costs. If one team of men is doing several operations this follows

FELLING DIRECTION WHERE ROW'S DIRECTION
IS NOT RELATED TO SLOPE

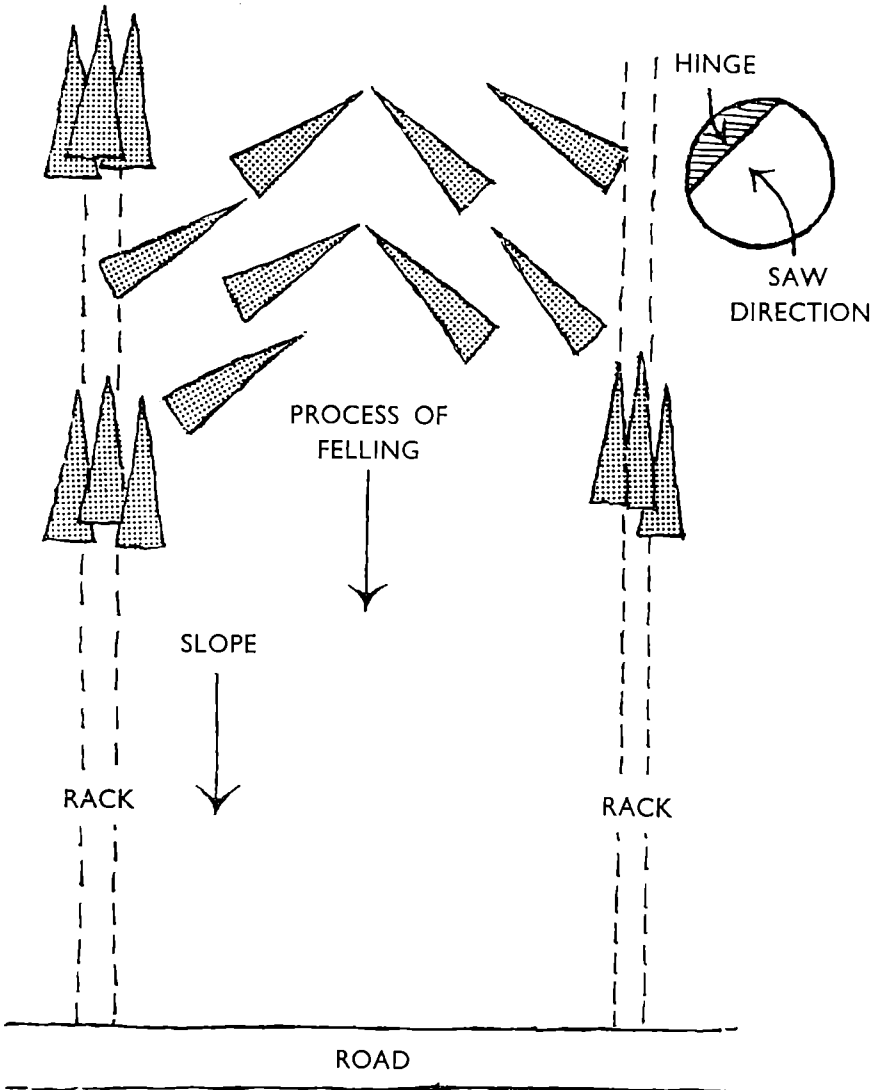

Fig. 12. Lay-out of Thinning Operations where Slope is not Significant.

almost automatically. For instance peeling and hand extraction by the feller have three advantages:

- (i) Trees are felled in the best direction to suit hand extraction.
- (ii) Branches are trimmed close to stem to facilitate peeling.
- (iii) Freshly peeled trees are easier to hand-extract as they slide over brush and stumps.

The completion of conversion at stump by the feller has similar advantages and where extraction is easy, this method is most successful.

FELLING METHOD--ORDINARY FELLER

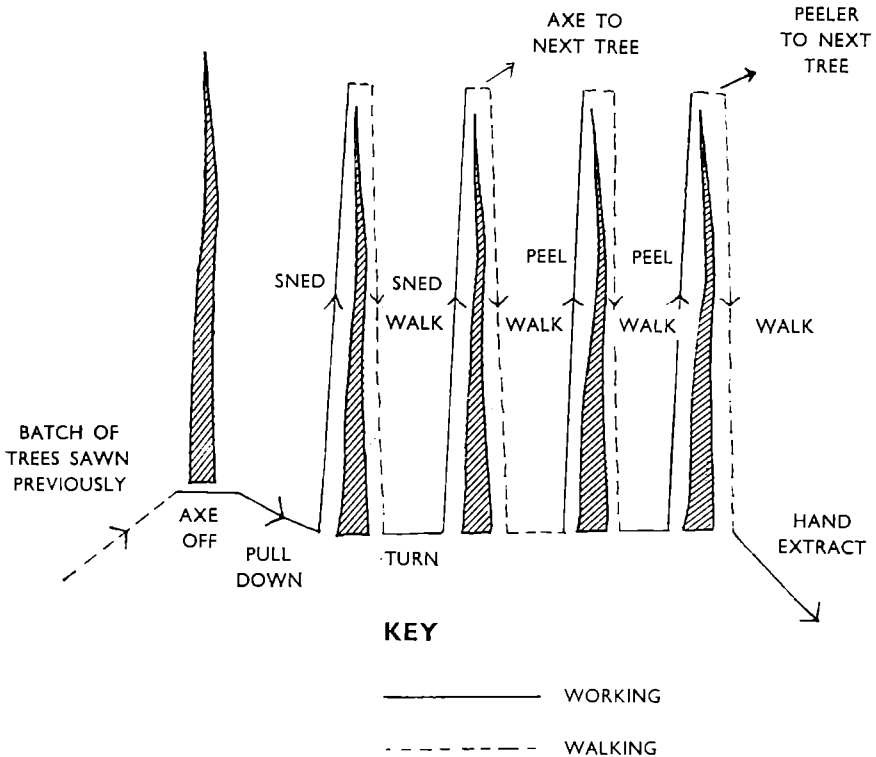

Fig. 13. A Good working Method for an Ordinary Feller.

(3). Method of Working

We now come to the part over which the feller has control. The sequence of operations is important. There is no doubt that much time and effort can be saved if each tree is first brushed with the axe, sawn, pulled down, sned, peeled and hand extracted by one man completing one tree at a time. This cuts down the walking to the tree to the minimum, any other method means that anything from two to four extra "walks" have to be made for every tree, each taking between 0.25 and 1.25 of a minute. All systems of working should therefore aim at the fewest possible visits to each tree.

Figure 12 shows a good working method. A batch of trees is first sawn by a pair of fellers who then separate and perform the operations in the sequence shown. With one man working, trees would be sawn individually, instead of in

a batch. The tree is then sned, progressing from butt to tip, and cutting off branches for at least $\frac{3}{4}$ of the circumference; on reaching the top it is cut off and the man returns to the butt and turns the tree. Time can be saved by turning small trees from the tip. The remaining snedding and then the peeling are completed in similar fashion. On completion of snedding the axe should be dropped at the next tree ready for axing off the hinge. Similarly the peeler should be put in a position where it is to hand when the next tree has been pulled down.

FELLING METHOD— ACE FELLER

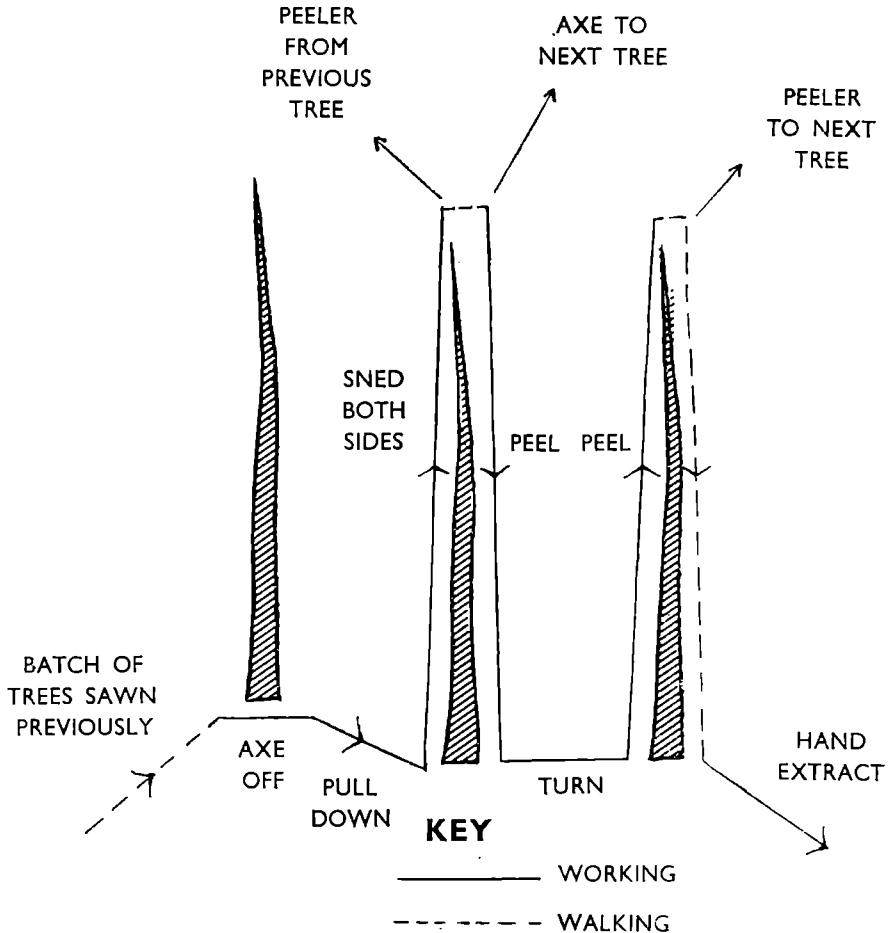

Fig. 14. Working Method for an Ace Feller.

It is possible for a very highly skilled feller to completely sned in one pass up the tree. The ability to do this is dependent on the development of one particular axe stroke, in which the axe is held close to its head with both hands. The feller then bends over the tree to cut the underneath branches from the side opposite him, making sure he does not cut his toes or shins in the process. By peeling from tip to butt, the number of walks along the length of the tree can thus be cut to a minimum. (See Figure 14.)

Opinions are divided as to whether horse extraction is easier tip first or butt first; both methods are used with apparently equal success, but the feller should also be considered as well as the horse. If the trees are in rows at right angles to the contour, as is usually the case on steep hill-sides, it is a simple matter to specify that the trees should be laid in the rows, or in one row in three or four. Thinnings, very rarely fall freely, so there is little risk of damage when the trees are felled tip first down the hill. This has the advantages that:

- (i) Snedding proceeds downhill. If trees are laid tops uphill, each axe stroke has to be directed upwards—a most tiring procedure.
- (ii) It is safer to pull a large butt uphill than downhill while getting the pole down.

Thus on steep slopes, where planting rows run up and down, felling should commence at the bottom and progress uphill, and extraction will be tip first. (See Figure 11.)

On turf-planted areas, the rows usually run at an angle across the slope, following the main drains herring-bone fashion. Generally such rows do not form the most direct extraction routes, and the best felling direction for ease of extraction is with the butts at an angle towards the nearest rack or lane. Wherever possible the hand extraction should take place through the *unthinned* area, so that brash and tops do not hinder progress. Pulling down is made easier by felling the trees into the gaps of the already thinned area. Felling under these conditions starts at the top of the hill and works down, and extraction will be butt first. (See Figure 12.)

(4). **Felling**

Axe felling of thinnings is wasteful of timber and is slower on any but the smallest trees that can be cut with two or three blows. Use of a cross-cut saw entails two men visiting each tree, but with a one-man bow saw, trees can be completely processed at one visit. The Swedish bow saws designed for felling by one man have the frame tapered to make it easier to control. The technique of using these saws is to stand with a foot on either side of the tree, bending over so that one saws towards the feet. The right hand is placed on the handle close to the blade, the left hand on the frame of the saw.

On trees that are too large for the bow saw, a two-man raker-tooth cross cut is the usual tool, though some prefer to use a larger bow saw worked by two men. Where large and small trees are mixed it is worthwhile having both one-man and two-man saws, provided the large trees are not too numerous. The sawing is the most arduous part of the job because it involves hand work in an awkward position. It is therefore advisable to break up the sawing into short periods over the day, rather than complete the day's sawing in one spell.

Once it becomes necessary to use a two-man saw, it is no longer feasible to completely process each tree in turn. A batch of trees must be sawn first; most teams prefer to work in regular sized batches to facilitate keeping a count. After sawing a batch, the saw should be hung up on the next tree to be sawn. The two fellers should then separate and continue with the other operations on each tree, only calling for assistance when absolutely necessary, e.g. for pulling down an awkward tree or extracting a large one.

A common practice is to saw through the tree until the blade starts to pinch, and then to withdraw the saw. The unsawn piece acts as a hinge to control the direction of fall. If the tree falls in the interval between sawing and snedding, it will drop in the right direction. With the narrow bow saw blades, it is possible to saw right through the tree, pulling the tree off the stump and

over the saw. In this case sawing starts from the side towards which the tree will fall. (See Figure 15.) This method is satisfactory on hard ground, but on peat, the butt sinks in unless the tree is pulled right down at once.

SAWING METHOD AND DIRECTION OF FALL

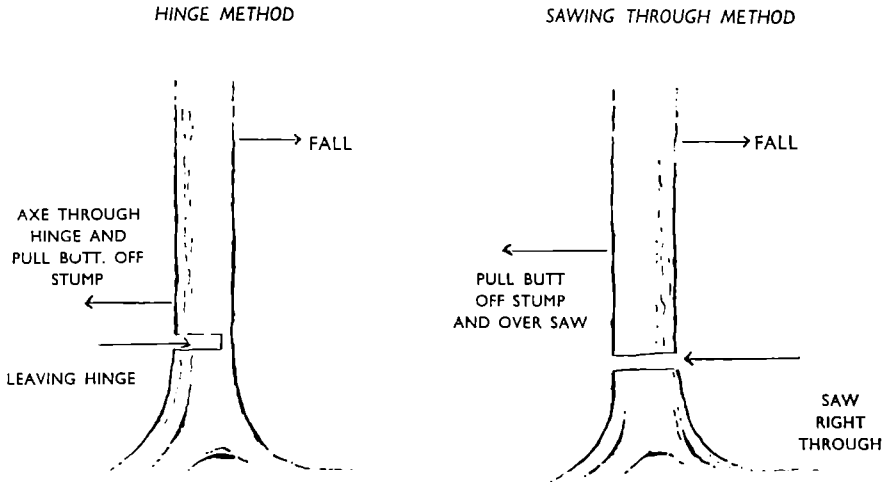

Fig. 15. Two Sawing Methods.

In thinnings, particularly in spruces, trees do not fall freely, but have to be pulled down. This is usually done by pulling the butt off the stump and along the ground until the tree falls. To get an effective pull either with the axe, hands or with the shoulder is not easy, and long-handled tongs have been developed for this purpose. They are most effective in trees from 1 to 6 hoppus feet, and can be used by either one or two men.

In large thinnings when the canopy is dense, a length of rope with a hook on the end is effective. The hook is placed round a branch as high up the tree as possible, on the side away from the direction of fall; a light 15-foot pole is used for the purpose. Pulling on the rope when the tree has been sawn through brings it down. The rope should be long enough; so that the men do not pull the tree on top of themselves.

(5). Snedding and Peeling

The good feller on both felling and peeling treats more than half of the circumference of the tree, so that after turning, there remains only a small portion to complete. This ensures that:

- (i) The tree only has to be turned once during snedding and once during peeling.
- (ii) When the tree is turned the remaining snedding or peeling is easily seen and accessible.
- (iii) As much as possible of tree is sned or peeled in its first more stable position—once a tree is turned it is often difficult to get it to remain in the desired position.

Many fellers reduce the length of their axe shafts from the standard 36 inches, either by cutting off the fawn foot or by sinking the head further down the shaft. The reason for doing this is that the major part of the job consists of cutting small branches and there is no advantage in taking a full swing. The axe is held part way down the shaft and the last 6 inches are merely an encumbrance. Presumably the 36 inch shaft was originally found to be best for laying in, but this is hardly ever necessary in early thinnings. Shorter shafts are now made by some manufacturers.

Trials with lighter weights of axe have shown that once men have become accustomed to them they prefer them. For spruces a 4 lb. is satisfactory, for larch and pines even lighter may be preferable. Apart from the fact that a shorter-shafted and lighter axe is less tiring to work with, it is also appreciably cheaper to purchase.

A practical safety precaution when snedding is always to make the axe strike the tree after it has passed one's legs. If the axe bounces off due to a faulty stroke it is then deflected away from the legs.

SWEDISH TYPE PEELER

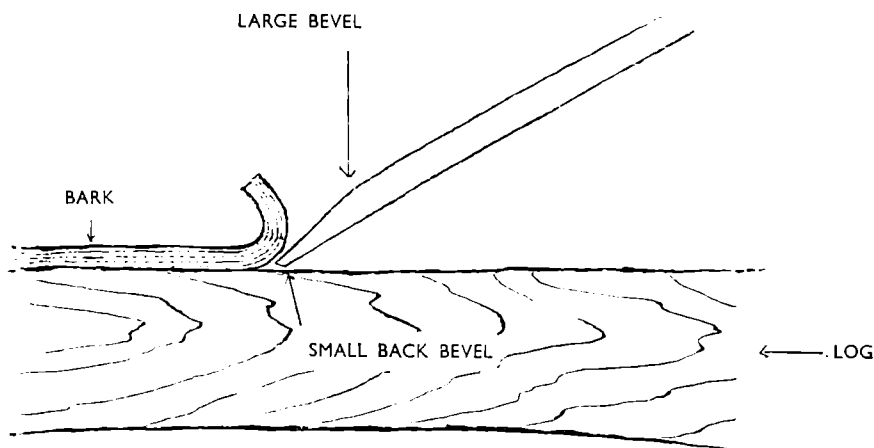

Fig. 16. Use of the Swedish Type Peeler.

The introduction of Swedish peelers with the longer shafts and lighter blades than the standard British patterns have improved output. To be fully effective this tool has to be used with long sweeping strokes using the whole body in place of short jabbing strokes with the arms. The correct setting of a back bevel to suit the man's own preference is most important on these peelers. Figure 16 shows this, note that the large bevel faces upwards—it is the small back bevel that prevents the peeler digging into the wood. The detachable blade type has the advantage that a chipped blade can be quickly replaced.

(6). Hand Extraction

A pair of long-handled tongs or a length of rope noosed over the butt makes it possible to drag the tree along the ground without having to pick it up. This makes the job easier and safer than carrying poles on a man's shoulder.

(7). Method Summary

Good working methods have the following features:

- (i) The various jobs are done in succession so that a variety of muscles are used. It is a mistake to work in such large batches that the sawing takes so long as to cause exhaustion, from which it takes a long rest to recover.
- (ii) The work should be planned so that the number of separate visits to each tree are reduced to a minimum—the ideal is one visit by one man who does the whole process.
- (iii) Tools should be placed where they will next be required. On completion of sawing, the saw should be hung on the next tree and similarly the axe and peeler placed at the foot.
- (iv) Tools should be well maintained.

(8). Conclusion

Attention to such details causes the difference between the feller who just makes his money, and the feller who earns double his time-work wage. Although conditions are not the same in all crops and in all parts of the country, detail of this kind can be noted by careful observation and passed on to the less experienced worker.

**REPORT ON THE FOREST WORKERS' COURSE
AT LAUBAU IN BAVARIA
AUGUST 24th TO SEPTEMBER 6th, 1958**

By C. ALLISON

Assistant Forester, New Forest

*We reproduce this informative report below, just as it was received.
For comparison with British units, the following data may be noted:*

1 Deutschmark (D.M.)	= 1s. 9d. approx.
1 cubic metre	= 35.34 true cubic feet
	= 27.74 hoppus feet.
1 hectare	= 2½ acres

I should first like to record my appreciation for the wonderful hospitality accorded me by Forstmeister Wild and his staff at Laubau, also for their great patience in explaining the many techniques which were quite foreign to me.

The course was most efficiently run, the aim being obviously to instruct the worker, not only on the best manner to perform his duties and maintain his tools, but also to instruct him as to why he was doing this particular work in this particular manner.

TYPES OF SOIL IN THE BAVARIAN MOUNTAINS

(1). IN THE VALLEY: Geological descent—Alluvium.

(a) **Deep weathered fresh loam**, ideal for the growing of broadleaved trees and spruce, although the latter often suffers considerably from butt rot.

If cleared in large areas the great danger here is frost. Grass invades the area. So the silvicultural system employed is:—Natural or artificial regeneration under a shelterwood.

As a point of interest, the local peasants have grazing rights over most of these areas. Fencing of such areas is only allowed for 10 years (theoretically until the plants have grown higher than the mouths of the cattle!), and must be restricted to small areas only.

(b) **Slightly weathered, dry gravel soil with little humus.** On this type of valley soil only Scots pine, (usually of poor quality) is found along with some whitebeam and juniper.

The stocking is usually light and much of the soil is covered by *Erica carnea* which prevents natural regeneration to a large extent.

To combat this some effort has been made to create an understorey by planting hornbeam and maple.

Spruce is able to grow only under the pine shelter, and when it does grow up it becomes very branchy—and often dies when it gets out of the shade of the pine.

(2). **SOILS ON THE MOUNTAIN SLOPES** (Figure 17).

Geological descent—LIMESTONE.

The soils derived have, of course, a good pH, but in the sun become very hot. and cold in the shade.

Firstly let us deal with the “Shadow Side”

(a) **Up to 900 metres:**

See Fig. 17a.

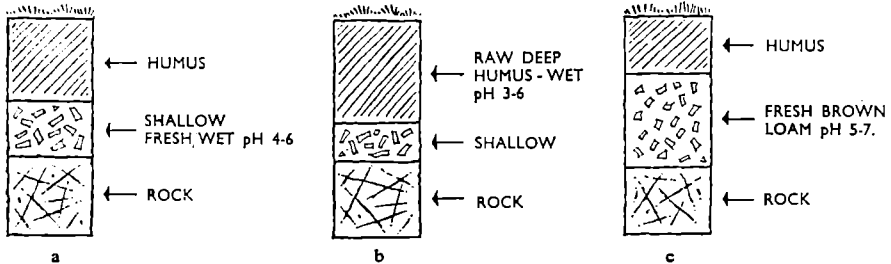

Fig. 17. Mountain Soils.

“The Sunny Side”

(a) **Up to 1,000 metres:**

See Fig. 17b.

<i>Silver fir</i>	<i>Spruce</i>	<i>Larch and pine</i>	<i>Beech and Maple</i>
15%	50%	5%	30%

(b) **1,000 to 1,400 metres:**

See Fig. 17c.

<i>Silver fir</i>	<i>Spruce</i>	<i>Maple, beech, whitebeam</i>
10%	70%	20%

(c) **1,400 to 1,700 metres:**

Similar to Fig. 17c but very dry—humus nearly sterile. Almost 100 per cent spruce—a little larch. Much mountain pine creeping about especially on the poorest sites at high altitudes.

Very wisely it is forbidden to cut the mountain pine nowadays. At one time it used to be cut and used for medicinal purposes—a cure for asthma, I believe.

Climate and Location

Laubau lies in a steep-sided valley about 3,000 feet above sea level, with the mountains in the immediate vicinity rising to 5,000 to 6,000 feet, extensively wooded right to the summits. The Austrian border is very close at hand. Some of the frontier guards live in Laubau.

The climate is Continental (Alpine), the summers being generally warm and dry and an abundance of snow from November to March.

Ruhpolding, a nearby village, is quite a popular tourist resort all the year round (skiing in winter). The village of Berchtesgaden, so well known to all of us at least in name, is very close at hand, although the Hitler house can no longer be seen, having been destroyed to “erase all memories”, as the local people told me.

The nearest place of any size is Salzburg in Austria, some 20 to 30 miles away, with its famous castle and its catacombs.

Having dealt with a general description of the soils encountered and the geography of the place, the following is a day-by-day report on the actual course and the points of interest arising.

FIRST WEEK

Monday

Having arrived on the Sunday evening and met the rest of my comrades on the course, who incidentally were all Bavarian mountain workers, I felt very much a “foreigner” at first, especially as I was the only one not in some form of local costume, which varies from village to village. However, thanks to their unstinting hospitality I soon felt very much one of them in spite of my dress and the fact that I had not brought my axe, saw and “sapie” with me.

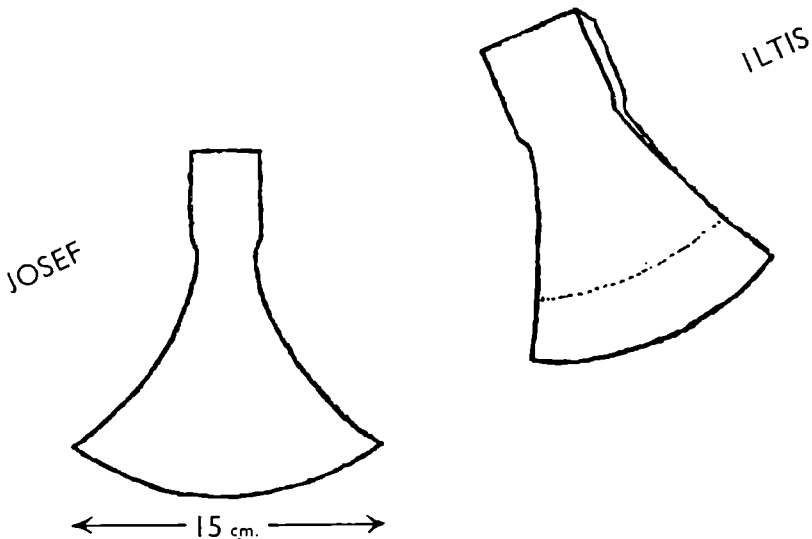

Fig. 18. Axe Heads.

We were greeted on the Monday morning, after breakfast, by the "Head", Forstmeister Wild and his staff which consisted, besides himself, of a forester instructor and 3 extremely capable foremen instructors.

We were split into three squads of ten men, and the first thing to happen was an inspection of the tools used by each worker—axe, saw and sapie. Workers buy all their own tools. The style and state of each tool is recorded: for example, for an axe, style of head and weight, length of handle, etc. It is interesting to note the influence this course has had in the past, on the state of the tools now being used by the workers.

A brief note on the tools:—

Axes (Figure 18). The Oberbayer 'Josef' style axe appears to be very popular, also the 'Iltis'. Length of the cutting blade is usually about 15 cms.

These axes are favourites for softwoods. For hardwoods a narrower blade is favoured, e.g., the 'Rheinische' axe and the 'Berliner', with a length of cutting blade of 12 and 9 cms. respectively.

Although very light by British standards, I was soon able to adapt myself to these forms of axes, although at first scorning their lightness.

Handles were mostly of beech, as in the mountains there is rather a shortage of ash. If a man, gripping the head of his axe in the palm of his hand, with his arm outstretched, could comfortably tuck the top of his handle under the armpit—then his handle was stated to be the right length.

The Sapie is a tool like a peavie or cant-hook, and I can only say I was astounded by the skilful way this simple tool is used as well as by its numerous uses, levering, lifting, pulling, stacking etc. Proof of my admiration for this tool lies in the fact that I brought one back home with me!

Saws used are mostly raker type, many of them Sandviks, with cutting teeth in fours, some with cutting teeth in pairs. All were thin to back. Occasional peg tooth and Tyrol style saws are still in evidence however.

Most workers I asked, admitted they had a motor saw at home and rarely used the two-man crosscut.

This inspection over, we had an hour's instruction on saws including their history, the method of manufacture and the theory of cutting and sharpening. The main points to think of when choosing a saw were listed as follows:—

- (1) Length of saw should be 1 metre (3 ft.) plus diameter of the tree.
- (2) Should be hollow-backed to allow for early wedging.
- (3) Thin to back (0.4 to 1.0 mm.).
- (4) Should have easily detachable handles.
- (5) Made by a good reliable firm.
- (6) Should have a resonant tone when tapped.
- (7) Should bend easily, a sign of good material and tension.
- (8) Sold by a reliable retailer.

The next hour was spent on filing the raker teeth. Each man was given a piece of crosscut saw and under the ever-watchful eye of a foreman instructor, had to file the raker teeth.

The stands, provided for sharpening, were of a very practical design allowing 2 angles. Upright for filing the rakers and tilted at an angle of about 30° for the cutting teeth. Lines are engraved across the front of these stands to correspond with the correct filing angles for the cutting teeth (70°). All one has

to do is to follow the direction of these lines, and bad filing becomes virtually impossible. Keys were provided to check filing and cutting angles. (See Figure 19.)

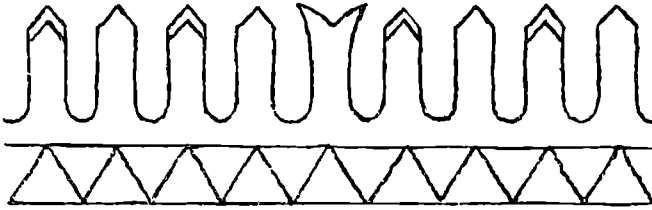

Fig. 19. Filing Angles.

These stands can be clamped to an ordinary bench or to the conventional upright frame, with base platform for standing on.

Good files were used—not spiral threaded—the die was turned when the other side of the file was cut.

Old files were used as stripping files, being put in the simple wooden clamp as illustrated in Figure 20.

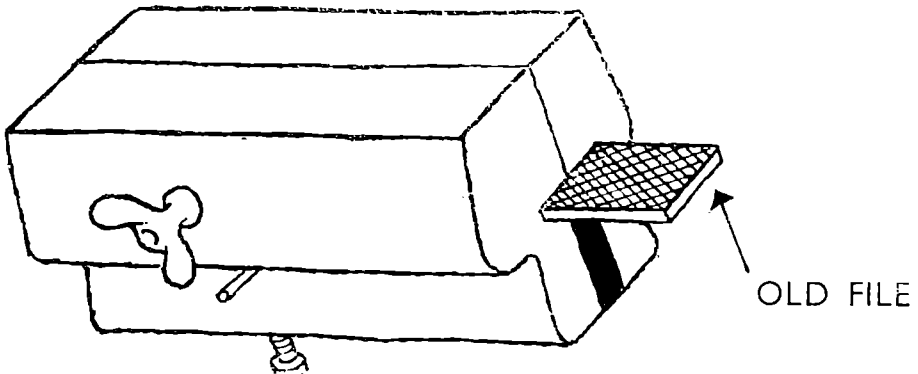

Fig. 20. Old File Mounted in Clamp for Stripping Saw Teeth.

The next half hour was spent on instruction in cleaning in young natural regeneration. Later we had ample opportunity to put these theories into practice. Tools used are some very excellent thinning shears, along with pocket secateurs, a light pruning saw and light hook. These last three articles are normally carried in a leather sheath case which is attached to a belt.

Cleanings are carried out in 3-year cycles beginning at an early age, when the trees are about 8 feet high. Our actual practice in cleaning was done in a plot of natural regeneration, which had been felled 1945 to 1947 in three consecutive fellings. The ground was entirely covered, beech being predominant as so often is the case when natural regeneration takes place on this limestone soil on the lower slopes.

Higher up the slopes it appears to be more checked by the frost and so spruce has a better chance of survival.

Spruce, larch, ash and elm occurred throughout our area as well as a little silver fir. The aim is to give sufficient room to the spruce which is the most valuable tree. Only the very best beech are left. Ample crown room must be

given to the larch, a light demander and desirable in the mixture. The best silver fir are given some encouragement as well, although these are tolerant of more shade.

As stated previously, spruce and others are apt to be suppressed by the prolific beech growth, so the best beech are selected and others are cut off at a height of 4 to 5 feet above ground. This is to enable the snow in winter to percolate through the branches left, thus avoiding a build up of snow around the crowns of the young favoured trees and the avoidance of snowbreak. By this method the soil is also kept covered.

Where beech does occur more or less *pure*, the aim is to have three storeys. Obvious undesirables are cut off at ground level. They will in turn spring up again and form the lower storey.

Very thin whippy beech have their tops cut off. They would fall over with the weight of the snow in any case. Again the snow can drop through and does not endanger the better beech. This group will in turn shoot out and form the *middle storey*. They also help by acting as "pruners" to the better beech.

The better beech are the ones which are allowed to grow on unmolested and form the *upper storey*.

Thus at all stages the ground is kept covered and snow break minimized. The average cleaning cost in Upper Bavaria for such a plantation is in the region of 80 D.M. per hectare.

After lunch another half hour was spent in filing the raker teeth. The rest of the afternoon, the 3 groups split up, each group doing:

- (1) *Group*: One-man work in small thinnings.
- (2) *Group*: Planting techniques.
- (3) *Group*: Cleaning.

I was a member of the third group, the technique of which I have just described.

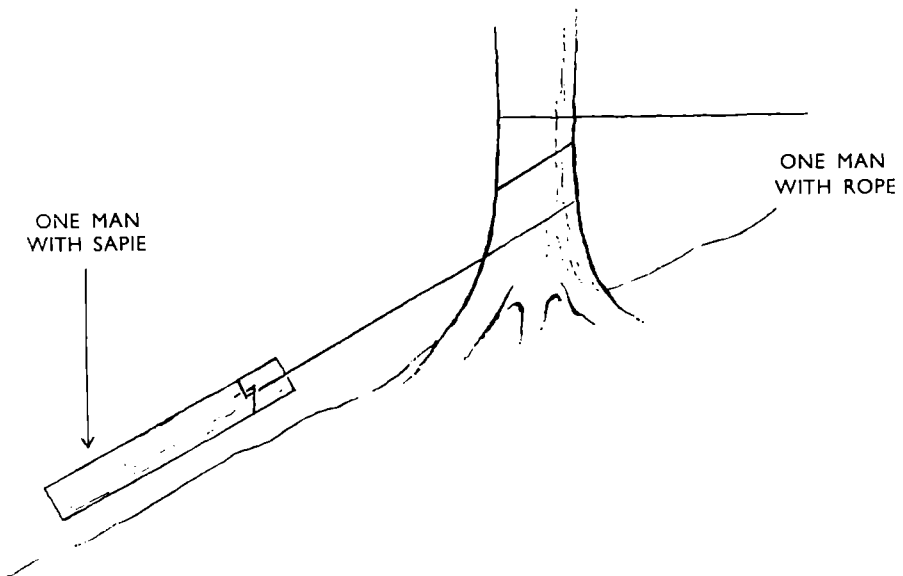

Fig. 21. Getting logs downhill with Rope and Sapie.

At 5 p.m. we had a lecture on 'first aid' by the leader of the Ruhpolding First Aid Team, himself a Forest foreman on a nearby beat.

After supper a most interesting film on cable extraction in the mountains, was shown. This film is the only one of its kind to have been made and is thoroughly to be recommended; it is called *Seilbringung in Gebirge*, which means "Cable Haulage in the Hills".

The film shows the colossal damage caused by self extraction down the mountain side, damage to both standing crop and log, to begin with.

Hand extracting down the slope with one man using the sapie to pull the log and the other paying out the rope, wound around the anchor tree, was the next to be seen. This method is all right for short distances. See Figure 21.

The portable winch, screwed into the stump of a tree, was shown. Sometimes this may be driven from a two-man motor saw.

The Swiss Motor Cable Winch stands on the road and is anchored by metal pins driven at an angle into a plate, in the ground. This method is used for pulling logs up to a road. See Figure 22.

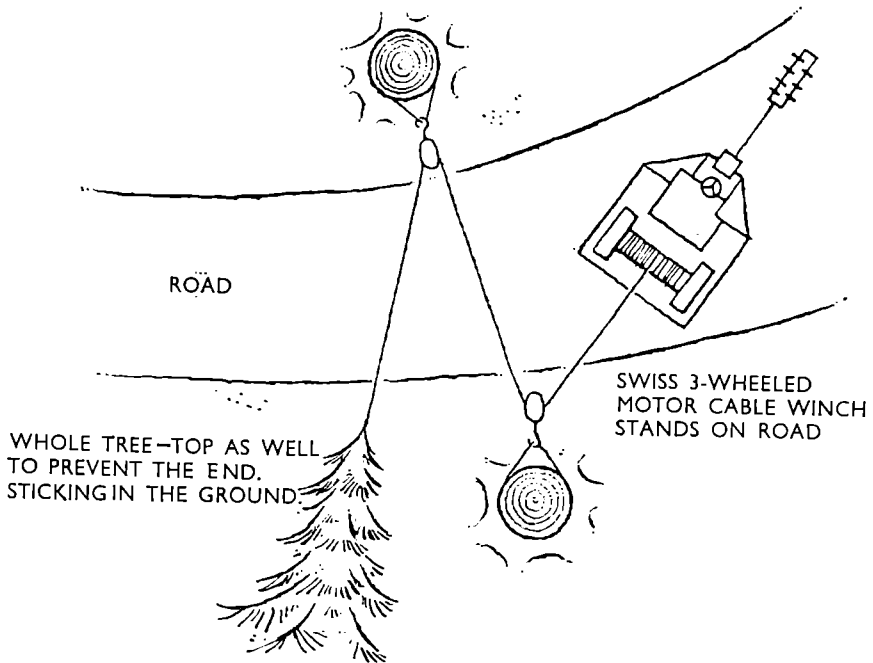

Fig. 22. Use of Swiss Motor Cable Winch.

The butt end must be down-hill, otherwise the machine can only be used for letting down the hill. The whole tree, complete with top, is hauled up, otherwise the top end would stick in the ground.

For longer distances a full scale overhead cable is often erected, with a single or double sling for attaching the logs. With the double sling there is much more steadiness (less swing) of course. Timber is brought to the cable by sledge (in winter), or by "Loite", which is a kind of flume constructed with the timber itself, highly skilled work which I will describe later (p. 71).

This winter, in Ruhpolding East, 1,000 cubic metres were extracted by this method, employing four men. See Figures 23 and 24.

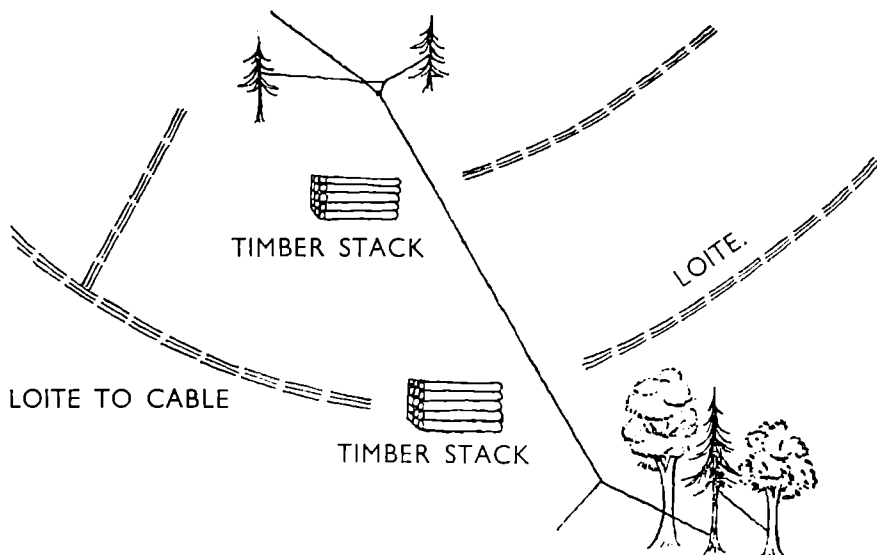

Fig. 23. Use of Cable and Loite: Plan.

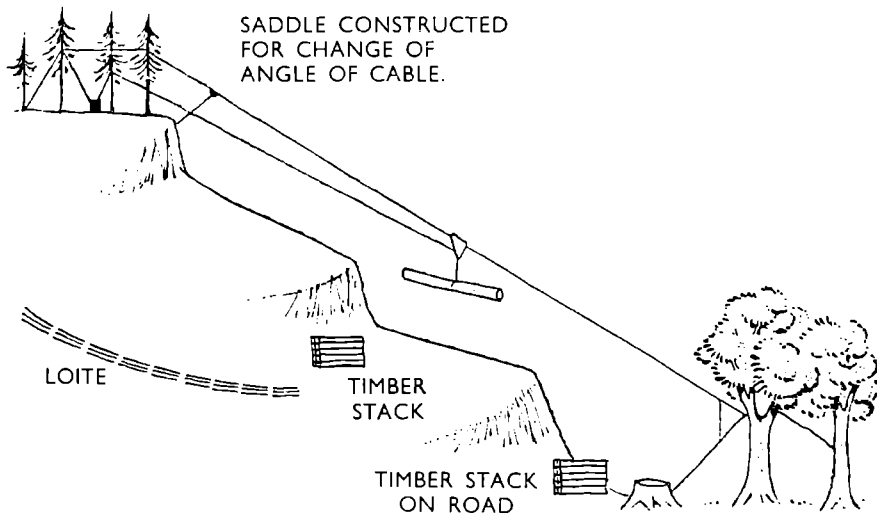

Fig. 24. Use of Cable and Loite: Diagrammatic Vertical View.

This ended the first day, quite a long day but most interesting. Normally we started the day at 7.15 a.m. with a break in the mid-morning for a sandwich, an hour's break at mid-day and the evening meal at 6 p.m. ended the day, except on the occasions when there was a film after supper.

Tuesday

The first lecture was on general revision of what we had already learned, followed up by more filing of the raker teeth.

There was an hour's lecture on the *Axe*, dealing with correct hang of the axe, the types most commonly used, the history of the axe and its manufacture.

Another hour was spent on filing the "rakers" again and a beginning was made on the cutting teeth by way of a change!

The last lecture before lunch was on *Other Tools* and covered Splitting (cleaving) Axes, Wedges, Peeling Spades and Measuring Sticks.

The 4 types of wedge shown were:—

- (1) Wooden.
- (2) Steel.
- (3) Wood-Steel.
- (4) Duraluminium.

I was interested to hear that No. 2 (the iron wedge) is not allowed in Bavarian State Forests. I know well of the dangers it can cause when the end becomes burred with constant hammering.

The wood-iron wedge is used a lot. See Figure 25.

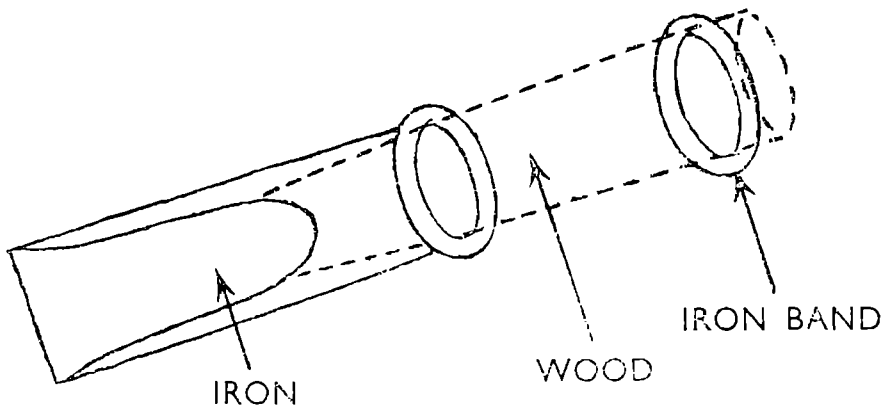

Fig. 25. Wood-Iron Wedge.

The very light duraluminium wedge is to be recommended for its lightness and for the fact that it does not harm the saw should it come in contact with it. It can be carried very comfortably in the pocket.

Peeling Spades. All timber is peeled immediately after felling because of beetle damage, also to facilitate extraction. Experiments are being made with chemical sprays, but not to any great extent, and the cost appears to be somewhat high. The weight of the spades varied from 300 grm. to 600 grm. (12 to 24 lb.)

One type of peeler spade cuts on all 3 sides and can be used for snedding as well as peeling very small thinnings.

For spruce a curved blade is used (13 to 15 cm.) enabling broader strips of bark to be peeled.

For Scots pine, a tougher tree to peel, a normal flat blade is used, 10 to 12 cm. wide. See Figure 26.

Some more filing followed until lunchtime, then in the afternoon my group went *planting*. I do not wish to dwell too long on this subject as it is a subject in which they fall behind us in our country. Probably because they do not have such large artificial planting programmes to undertake, most of their woods being naturally regenerated from existing natural forest.

Notch planting is done with a mattock, with a pick and an axe end. See Figure 26.

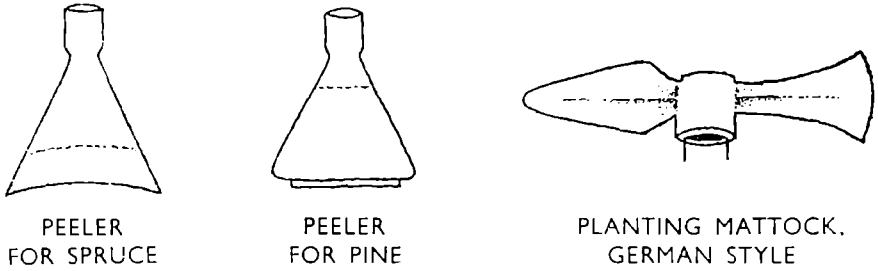

Fig. 26. Peeling Irons and Planting Mattock.

The planter stands feet apart and makes his first cut with the axe end at a point, which, the instructor delightfully suggests, is where the droppings from your nose will hit the ground! The second cut is made with the other end of the mattock, the turf is pulled back, whilst dropping the handle of the mattock over the right knee the plant is inserted, not at the joint of the notch, but at position "X" where the soil is more friable and not so compacted by the clean cut of the mattock as at the joint. See Figure 27.

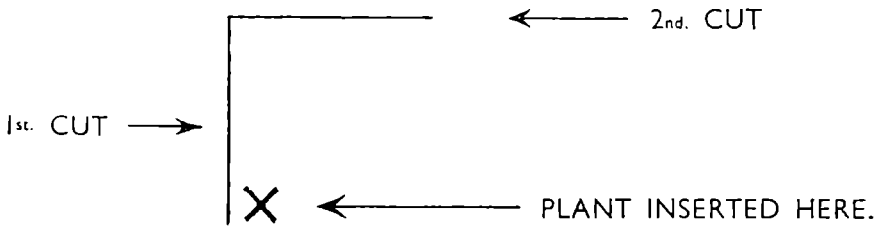

Fig. 27. Peculiar Form of L-Notch.

For very small plants "Schlag" planting is used. As the name implies, the plant *leans over*, towards the upper slope. The snow pressing against it in winter helps to straighten it. Only the broad end of the mattock is used.

A form of pit planting, *Lochpflanzung*, is used which I can only think must be most expensive. For this method the mattock is also used and the man requires the assistance of a woman worker or boy, who rakes and presses the soil around the plant with a small tool, shown in Figure 28.

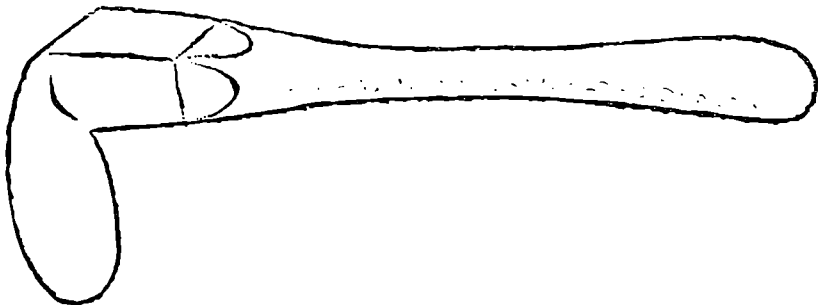

Fig. 28. Pit-planting Tool.

Another quite common method for bigger plants is T planting. An elaborate "T" is made in the turf, and both "flaps" of the T are pulled back. Whilst the man is holding the turf back the lady assistant comes up with the above illustrated tool and plants the plant!

In all methods plants are carried in a basket. I mentioned our planting bag to Herr Wild and he was most impressed with the idea.

Another lecture followed on First Aid, and after supper two films were shown, *Einmannarbeit* (one-man work) and *Loitenbau*. (building a *Loite*)

Wednesday

As usual the day began with revision, followed by filing and grinding and sharpening axes.

Then followed an hour's lecture on Other Working Tools. Notable amongst these is the **one-man felling saw** which is good for smaller thinnings. See Figure 29.

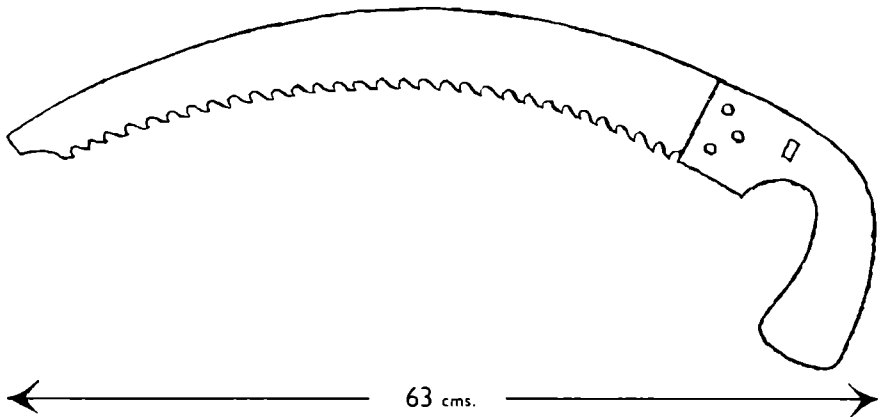

Fig. 29. One-man Felling Saw.

The length of the blade is about 63 cm. (2 ft.) although some are up to 1 metre (3 ft.) long and have a measuring scribe combined, so that they can easily be used for measuring off. These latter, however, are inclined to be too long and whippy.

Measuring sticks used are of 1 metre length, incorporating callipers at one end. In the mountains most heavy timber is cut into 4, 6, or 9 metre lengths. The 4 and 6 metre lengths can be **sledge** extracted and the 9's by **Loite**.

More filing came after this lecture.

In the afternoon we had our first introduction to felling on the mountain-side. We went by cable car up the Rauschberg mountain, taking our turn in the queue with a multitude of holiday makers. Once at the top a magnificent view could be enjoyed, but not for long. We descended to the felling area, passing wind-weathered spruce and mountain pine creeping all over the place.

Two groups did felling and one *Loitenbau*, changing over on the following days.

First to deal with the felling:—

The axes, previously described, are good and kept in good condition. The tree to thin is first snedded as far as one can reach. The easiest direction is

chosen to fell it, with the natural lean if possible but *NOT* downhill where it can be avoided, as the slope is *very* steep.

Attention is paid that no other tree may be wounded or that no natural regeneration be damaged when felling.

The men work in pairs, two pairs being close to each other so that if the occasion arises they can help one another. Safety precautions are rigorously adhered to. No person must work directly above another because of the danger of falling stones, etc. The two pairs work together at the same altitude, at least more than one tree length apart. One cannot be too careful on these very steep slopes. On more than one occasion I have had to dodge falling stones from above and, on one occasion, a tree which slid down.

The sink is made by both men chopping from his own side of the tree, alternately in synchronisation.

Theoretically the sink should be one-fifth of the diameter of the tree and should be deeper in the middle than at the edges so that the corners hold and guide the tree down better.

Trees felled downhill on very steep slopes may be wired above and below the sink to prevent "losing" them.

Trees are 'taken off' fairly low but not quite so low as in this country.

As a further precautionary measure warning is given on commencement of sawing, when the wedge is put in, and again when the tree is about to fall.

Sawing is done about 2 cm. above the level of the sink to allow the tree to "break out". In the event of the tree lodging in others it is quickly and

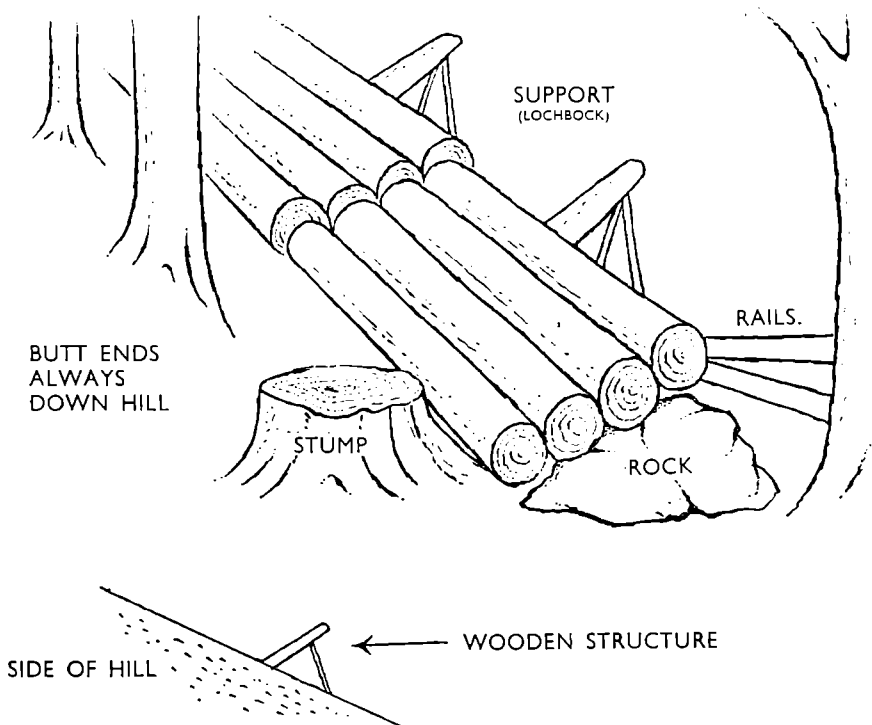

Fig. 30. Hangloite.

expertly levered down with the aid of sapies. Care in snedding is emphasized, always to strike away from the legs and body. Finally the log is peeled, and *spranzed* both ends. (The ends of the logs are tapered off with the axe to prevent digging in to ground when extracting.) Skill is generally very high, although I saw no real outstanding axeman, apart from the foremen instructors.

The cost of felling and extracting to *Loite* in this particular district was in the region of 10 to 12 D.Marks per cubic metre.

Loitenbau

This work greatly impressed me. It is a job demanding the utmost in skill, which almost died out some 30 years ago and which is only recently having to be retaught. It avoids the splintering and shattering which other methods of ground extraction result in on these difficult slopes. The work is done in summer ready for the rain to come, or on mild gradients the frozen snow, so that the timber can be extracted over it. (It slides easily after the rain.) Normally the wood goes much too speedily when frozen. The timber is extracted over the *Loite* and then finally the *Loite* itself is extracted, starting at the top and working down. Sledging is the chief form of extraction in winter, then the local peasants often tractor it to the stacking ground during slack periods.

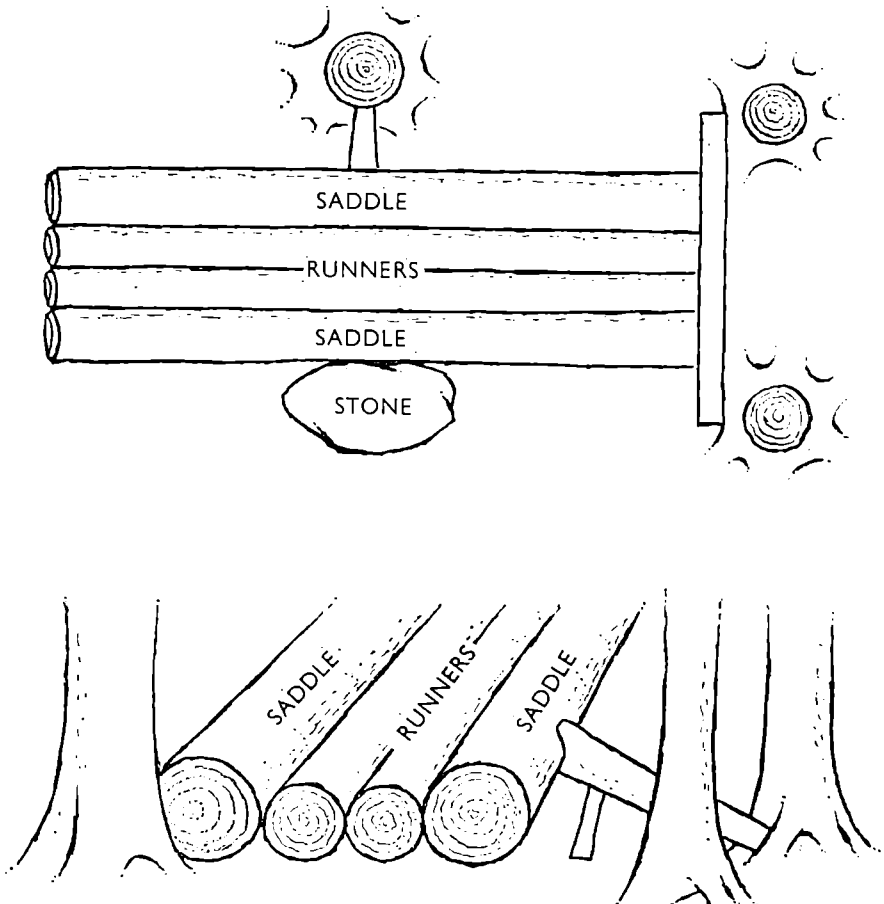

Fig. 31. Muldenloite.

The two main forms of "Loite" are:—

(1) the **Hangloite** and (2) the **Muldenloite**. First let us look at the **HANG-LOITE** shown in Figure 30.

The *Hangloite* is constructed across the slope. The wood is placed to form a channel, the slope itself forms one side of the channel, the *Loite* being built up to form the other, as shown in Figure 31.

The *Muldenloite* is the complete *Loite* consisting of 2 runners, 2 saddles, (bigger logs) and possibly 2 upper saddles. Every use is made of natural props to keep it in position, e.g., trees, stumps, rocks, etc. No nails or cords are used whatsoever, even when crossing ravines. Butt ends must always be placed down the hill. Looking down the *Loite* one should not be able to see any of the thin ends showing.

If there are no trees available to act as supports the *Loite* is held up by means of props, the two most notable types being the "Swallow prop" and the "Hole prop".

The cost of erecting *Loite* is usually about 1 D.M. per metre or where there are no trees 1.50 D.M. per metre. These are the piece-work prices often paid for *Muldenloite*.

In the evening a film on felling was seen.

Thursday

Revision and filing as usual in the morning followed by an explanation of the HOMA, which is merely the different produce classes.

There are so many classes right down to pulp and firewood that I can only say that this was most confusing. Even the instructors admitted it was very complicated. I think one would require much practical experience actually measuring off all these different sizes and top diameters before one could ever hope to try to fathom it out.

I found it quite a relief to get out to the ever-beloved filing after this lecture.

In the afternoon it was felling and *Loitenbau* again on the Rauschberg.

Friday

Revision, filing and a lecture on the Maintenance of Forest Roads was the order of the morning. The emphasis was on adequate drains to run off the water, the biggest enemy to a road.

Next my group went out on *Einmannarbeit* (one-man work) which consisted of an early thinning in a dense young spruce wood. Everyone worked singly, felling with the excellent one-man felling saw previously described. The trees are felled, pulled down, and trimmed and peeled with the peeling spade, the one with the 3 cutting edges. These small poles and rails are trimmed out to 2 cm. top.

The grade of thinning employed is light by our standards but there is always snowbreak to think about.

Saturday

We started as usual with a revision lecture and more filing and then a lecture on saw setting. All the usual well known setting methods were demonstrated.

An hour's practical road repairing followed this lecture.

By way of relief we went back into the *Schlafräum*, as we affectionately called it, for a lecture on Correct Nourishment and Clothing for Forest Workers.

SECOND WEEK

Monday

The second week was almost a repetition of the first so I will deal with it briefly. Monday consisted of the old faithfuls revision and filing and a lecture on forest protection, which I missed because of helping an Italian film company in their making of a film on Alpine life.

After lunch it was back up the Rauschberg for more felling and *Loitenbau*.

Tuesday

On this day the usual routine was followed by the school. The lecture this day was on rates of pay, piece-work, overtime, etc. The German forest worker (State Forests) works a 45 hour week for a wage very similar to that of our own in this country. Very often he must live in a bothy in the woods from Monday until Friday evening, returning home on his motor-bike for the weekends. This is necessary as some of the places he has to work in, are very remote indeed.

I was lucky enough on this day to be invited along with a Swedish Head Forester, (instructor at a school) who stayed for 3 days with us, to spend the day with Herr Wild touring the neighbouring forest areas namely Reit-im-Winkl, where several fine *Loite* over ravines were seen.

From there we went to Badreichinhall. A very fine forest road runs as far as the Austrian border. Special permission had to be obtained from the Forest Office before we could travel on it. Some of the gradients are very steep and the overhang sheer in places.

Leading into the road at different levels were sledge tracks. Much blasting had to be done in the limestone to make the road and there are two very fine tunnels. Forstmeister Wild actually surveyed this particular stretch of road, with the tunnels, when doing his State Grade Test, and he can be justifiably proud of it.

The road winds high up into the mountains to the border, following roughly the old salt smugglers' track into Austria. Incidentally three of the forests over the border actually came under German administration.

Fine forest workers' bothies were seen where forest workers slept and lived during the working week. These huts, typical of the Alps, were also built by Herr Wild using forest labour only.

The cost of the road was 80 D.M. per metre but three times this cost for the tunnels. The average road-making cost in Bavaria for a metalled road is 17 to 18 D.M. per metre. Although dear the road eliminates much expensive cable or "Loite" extraction, although short aerial ropeways are still used to bring the wood from the highest slopes to the road. The road is expected to pay for itself in about 56 years.

Some original native Scots pine were seen which were not impressive.

On some of the lower slopes much spruce had been felled during the war: consequently, as usual on the lower slopes, beech gained the upper hand.

Many mountain goats may be seen in this area but we were unfortunate in not seeing any.

A *Seilbahn* railway was visited leading from a very narrow steep-sided valley. This cable is for wood only and is a permanent cable railway. The wood is brought down in the spring, having been extracted to the cable by sledge, in winter. Then it is off-loaded from the cable down on to the stacking ground, where it is graded ready for the merchant. This cable railway has no motor,

relying on the weight of the wire for motivation. With three men on top and three below, around 900 cubic feet can be brought down per day.

On the way home a halt was made at a wayside *Gasthaus* where "mine host" was a retired forest gamekeeper, quite the most magnificent specimen of a man I've seen. Clear sparkling eyes shone out from his full bearded face and I thought the bones of my hand would surely be crushed when he offered his huge hand in handshake. I was told by Forstmeister Wild that when he was working it was nothing for him to carry a stag weighing 160 pounds on his shoulder from the top of the mountain to the valley below.

A most enjoyable day was crowned, in the evening, when Herr Wild and myself attended a *Heimatabend*, in Ruhpolding, where traditional dancing, *Schuplattelen*, yodelling and singing were enjoyed to the full in a delightfully friendly atmosphere.

Wednesday

Wednesday followed more or less the pattern for the previous days except that much time was spent on practical conversion of timber in the forest. The afternoon was taken up with felling and *Loitenbau*.

Thursday and Friday

On Thursday we had revision and a short lecture on sales of produce as well as a talk by the Union representative. I paid a visit to Salzburg during this latter talk!

The rest of the time was taken up by the practical tests in filing, felling and *Loitenbau*, planting and cleaning.

In the planting test three men were called on at a time, and each asked to demonstrate different planting methods and the reasons for adopting them.

For cleaning, each man went up individually and was taken to a section of young forest to be asked which trees he would take out or lop, and which he would favour, and the reasons for doing so.

In felling each pair was closely watched whilst doing the actual work and questions were asked on problems which might crop up.

Loitenbau consisted again of practical work, constructing a section of *Loite*, with questions asked about each stage of the work and the difficulties likely to be encountered and how to surmount them.

Finally there were oral tests on:—

- (1) Conversion.
- (2) Working Tools.
- (3) Forest Protection.

Assisting with the oral examinations was the beat forester from Ruhpolding.

The last evening of the course we had a fine farewell get-together and sing-song. These mountain people are extremely talented as well as hospitable. Everyone could dance, yodel and sing most beautifully, not to mention drink beer by the litre.

Herr Wild and his staff kindly presented me with a fine local drinking mug, with a sprig of mountain pine tied on as well as Edelweiss flowers carved from wood—done by one of the instructors.

I could not adequately express my appreciation for the wonderful kindness and help accorded me by the whole staff, not forgetting the very important kitchen staff, and my fellow companions on the course.

SUMMARY

A great deal of instruction goes into the fourteen-day course without any semblance of overcrowding. The staff consists of a Forstmeister, a forester and three exceptionally capable foremen. One of these latter is the *Loitenbau* specialist.

The school takes adult forest workers from the age of 18 to 55 years. On successful completion of the course, the worker is entitled to additional proficiency pay. Each forest officer in Upper Bavaria recommends the workers he wishes to attend and everyone is very keen to go on the course.

It is a system which is, I think, to be highly recommended. We have no such system here but I am full of praise for it.

Faults in workmanship and care of tools can be corrected and more economical methods of working devised. The result is that both employer and employee benefit. The former by a better standard of workmanship and greater output and the latter by a high remuneration for his piece-work effort.

With this course operating I envisage the Upper Bavarian forest worker becoming the most efficient in the world.

One small example which may bear out already the benefits of instruction of forest workers:—

In 1953, in this district, statistics showed that on average, in *one* hour *one* man would fell 0.34 cubic metres at an average cost of 4.19 D.M. In 1955 the figures were 0.43 cubic metres at an average cost of 3.94 D.M.

This I think may well point to better tools, better working methods derived from the instruction of forest workers.

FOREST WORKERS' COURSE AT THE FOREST LABOUR SCHOOL, ARNHEM, HOLLAND, NOVEMBER, 1958

By D. J. JONES

Assistant Forester, North Wales

I attended this interesting and instructive Course for General Forest Workers, which lasted for three weeks. It is an excellent course for Forest Workers, based entirely on the Dutch "Good Work" method, and it deals with both theory and practice. The main part of the course is devoted to tools: their selection, care and maintenance, and also to practical work in the forest, and altogether it is a well organised course, staffed by an experienced team of instructors.

There are excellent facilities at the school itself; lecture rooms, saw-doctor rooms, workshops and also a cinema. There is, in addition, an extensive and comprehensive library containing instructional films and lantern slides covering all branches of forestry work in Holland, and also that in other European countries.

The short space of time available to them is used by the people responsible to the utmost for, in addition to the practical work in the field and workshops, ten evening lectures are given during the course.

As already mentioned, the course is based on the "Good Work" method, and the Dutch are fortunate in this respect because this method can be put into practice in all their forests. The method is beneficial to both employers and employees, but perfection will be reached only when both parties become acquainted with the practice and true running of the method.

It is a ruling in the Dutch Forest Service that all their Forest Officers are trained in this method, and most of their supervisory staff have attended one or more of these Courses. It is also hoped that Private Employers of Forestry Workers will be induced to attend the courses.

Throughout the course the emphasis is on the younger man, preferably of the 18 to 25 age group. But age does not bar a man from taking the course, provided he is physically fit and is keen to learn a new, easier and more profitable method of carrying out the many different tasks in the forest.

Men from all parts of Holland attend these courses, and when a man returns to his home forest it is presumed that the knowledge he has gained will, in time, be imparted to his fellow workers. Records of all the men who have attended a course are kept, and reports from the Forest Officers show that these men are putting into practice the knowledge they have gained.

If a man has shown talent for a specific task, e.g. sharpening of tools, particularly the many types of saws, his employer is contacted and a recommendation made that the man be given further training which will help him to become more proficient in the branch of forestry for which he has shown a special aptitude.

A new school, the first of its kind in Holland, is to be opened by the Dutch Forest Service for the training of the younger forest worker of the future, starting with the 15 to 16 age group.

I was impressed particularly by the instructional films and slides. A wealth of information, both to supervisory staff and forest worker, can be gained by these means, and I am convinced it would be a step in the right direction if a system could be set up whereby films and slides, of whatever country of origin, and covering all forestry operations, could be made available for display to forest workers. The films I saw in Holland were most interesting, but it would have been more beneficial if the information leaflets issued to me had been in English. Perhaps when more students from Britain are attending these courses, leaflets printed in English might be provided.

My report would not be complete unless I mention the generous hospitality offered to me by the Dutch forest staff. Their conduct and the interest they showed in their work impressed me very much. They would not hesitate to arrange an excursion, regardless of the distance involved, in order to deal with some item thought to be of interest to me. The most memorable of these excursions was to the reclaimed land of the Polders, where first-hand knowledge of the immensity of the task facing the Dutch nation, and how they are dealing with it, was gained. It proved most interesting to see what a very important part trees play in this vast enterprise; the reclaimed land without its quota of trees would be uninhabitable.

Finally I should like to express my gratitude to the International Labour Office for awarding me the privilege of being able to meet the Dutch Forester and Forest Worker, and working with them in their own forests.

MAINTENANCE OF JO-BU SAW CHAINS

By D. T. PATTERSON

Assistant Forester, East England

In use, the chain must be fully and efficiently lubricated. Lack of lubrication results in mechanical failure of the chain due to excessive wear, before the cutting life is expended.

Construction of Chain

The chain may be regarded as having three types of link with separate functions.

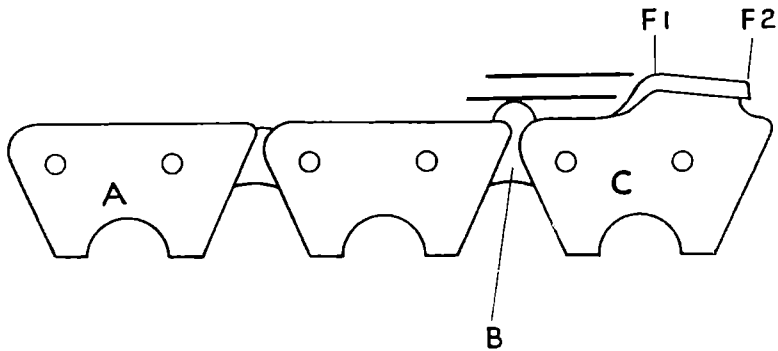

Fig. 32. Jo-bu Saw Teeth: First View.

They are illustrated here (Fig. 32) as A, the spacing link; B, the depth regulator and C, the cutter tooth. On a new chain, there are two consecutive spacing links A at one point. The only practicable means of shortening a chain to take up wear is by removing one of these links. Removal of further links would result in two consecutive cutters working on the same side of the chain, which would throw it out of balance.

The depth regulator B, is slightly lower than the edge of cutter C, thus allowing it to penetrate the timber only to a limited extent. In the absence of a depth regulator, the tooth would tend to feed in too deeply, stopping the saw.

The upper surface of the cutter tooth C, slopes downwards from the cutting edge F1 to the back, F2. The result of this slope is to reduce the depth of cut as the tooth is filed back in sharpening, by decreasing the height difference between cutter and regulator. The cutter may be filed back from F1 to within $\frac{1}{8}$ of an inch of F2 before the chain is worn out, the slight reduction in depth of cut compensating for wear and weakness in the chain generally.

To obtain smooth, fast cutting, the height difference between cutter and regulator must be constant throughout the chain. There are only twenty teeth on a Jo-bu Chipper Chain, and if one of these is higher than the others it will persistently stop the saw.

Regularity of height difference when sharpening, can be obtained by using the following method. Select the tooth which has sustained most damage in use, (on badly filed chains take the shortest tooth F1 to F2) sharpen it and it thus becomes the shortest tooth on the chain. Measure its length from F1 to F2 and file the remaining teeth to the same length, regardless of other considerations. The height difference is then constant, and it will now be evident why the depth regulator should never be filed.

If the chain is filed once or twice without removing it from the saw, the length of the cutter teeth begins to vary and consequently the saw cuts slowly and roughly. When this happens, it is time to adopt the above procedure.

Filing

This can only be done efficiently by using the correct diameter, 7 mm. file.

The chain should be lightly clamped in the vice, firmly enough to prevent movement of the cutter, but not so tightly as to squeeze together and distort the lower bearing surfaces of the links which run on the cutter bar. Grip the chain so that the rivets are resting on top of the vice jaws, not within them.

The correct angle of bevel on the cutter tooth is 40° , as illustrated in the Instruction Pamphlet issued with the saws. This angle must be regularly filed on all the teeth and, to maintain it, it will be found helpful if two crossed lines are filed across the top of the vice at this angle. The file can then be used parallel with one line when one side of the chain is filed, and parallel with the other line for the second side. The file must always be kept horizontal if it is not to cut down into, and damage, the connecting links.

The effect of allowing the file to cut into the linkage is illustrated in Fig. 33 and a similar effect is obtained if a file of too small diameter is used. The shape is such that, in cutting, the tooth tends to bite too deeply into the timber stopping the saw. The illustration exaggerates the fault but, in practice, a very slight tendency towards this shape results in persistent stoppage for which the machine may be blamed. The link tends to become weak, also, as metal is filed away close to the rivet holes.

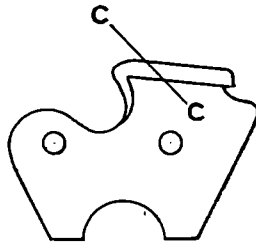

Fig. 33. Jo-bu Saw Teeth: Second View.

An enlarged view of a correctly sharpened cutter is shown in Fig. 34. Note that the bevel BB is obtained perfectly flat from edge to back, and also, the difference between angle CC in Fig. 33 and C_1 to C_2 in Fig. 34.

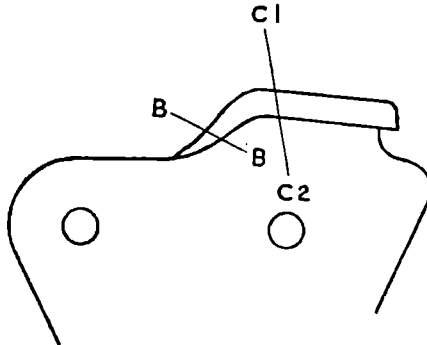

Fig. 34. Jo-bu Saw Teeth: Third View.

When the chain is replaced on the saw, it should be adjusted to allow three-sixteenths of an inch play at the top centre of the cutter bar. After fitting, ensure that there are no "tight spots", i.e. places where as it travels round, the chain tends to tighten due to uneven wear on driving sprocket, cutter bar or chain. If there is a tight spot, adjust the chain so that it has three-sixteenths of an inch play at that position, so that it always runs freely.

Book Review

SANDVIK FORESTRY SAWS

Sandvik Steel Works Company Ltd.

Free Issue

A Manual of Tool and Maintenance information issued, in 1958, by the Sandvik Steel Works Company Ltd., under the sign of Hook and Fish. This company specialises in Strip Steel, Wire and Tubes, and among their finished products are springs, machine knives—and saws.

The Right Saw

The booklet, which is profusely illustrated, opens with general tips on saw maintenance, and offers this important advice: Use a saw that is suitable for the size and type of wood, and a saw that suits your working style. To which might be added: The saw was made for man and not man for the saw.

All the differing types of forest saws and saw toothings are fully dealt with, showing working methods, the effects of different teeth, even the sawdust differences that result; which saw is best suited for green wood, which for dry wood, and how to ensure a smooth and vibrationless cut, even in gnarled wood. The right saw to choose, how best to use, and why.

Not only the most modern machines and hardening plants available, plus fine quality steel, go to the production of the saws, but research follows closely every development in the saw branch. Once in a while research results in important new tools, such as the "Hard-Point" bow saw blade. Developments like these are relatively scarce, because the saw in its present form is almost ideally suited for its work. There are rumours now and then of "wonder saws", but after undergoing tests most of them never come on the market, and the sawyer can rest assured that the only new types issued are those that are improvements on earlier types.

Safety

Regard is also had to the safety of the sawyer, as for instance, the tensioning lever on a new type Sandvik frame. This has been given a slack movement so that it can be opened about $\frac{3}{4}$ inch, before the eccentric force is engaged. Changing the blade is therefore safe and easy, and there can be no risk of injury to the hands.

Use and Maintenance

A complete review would require too much space, because this 62-page booklet is also a manual of instruction, and possibly some idea of the practical nature and value of the information contained therein may be deduced from the following extracts.



Plate 1. The Lewisburn Valley in Kielder Forest, before afforestation began.



Plate 2. The Lewisburn Valley, Kielder Forest, as it is today. Both photos are taken from the same point, just above the Boy Scouts' Camp Site, looking *up* the valley.

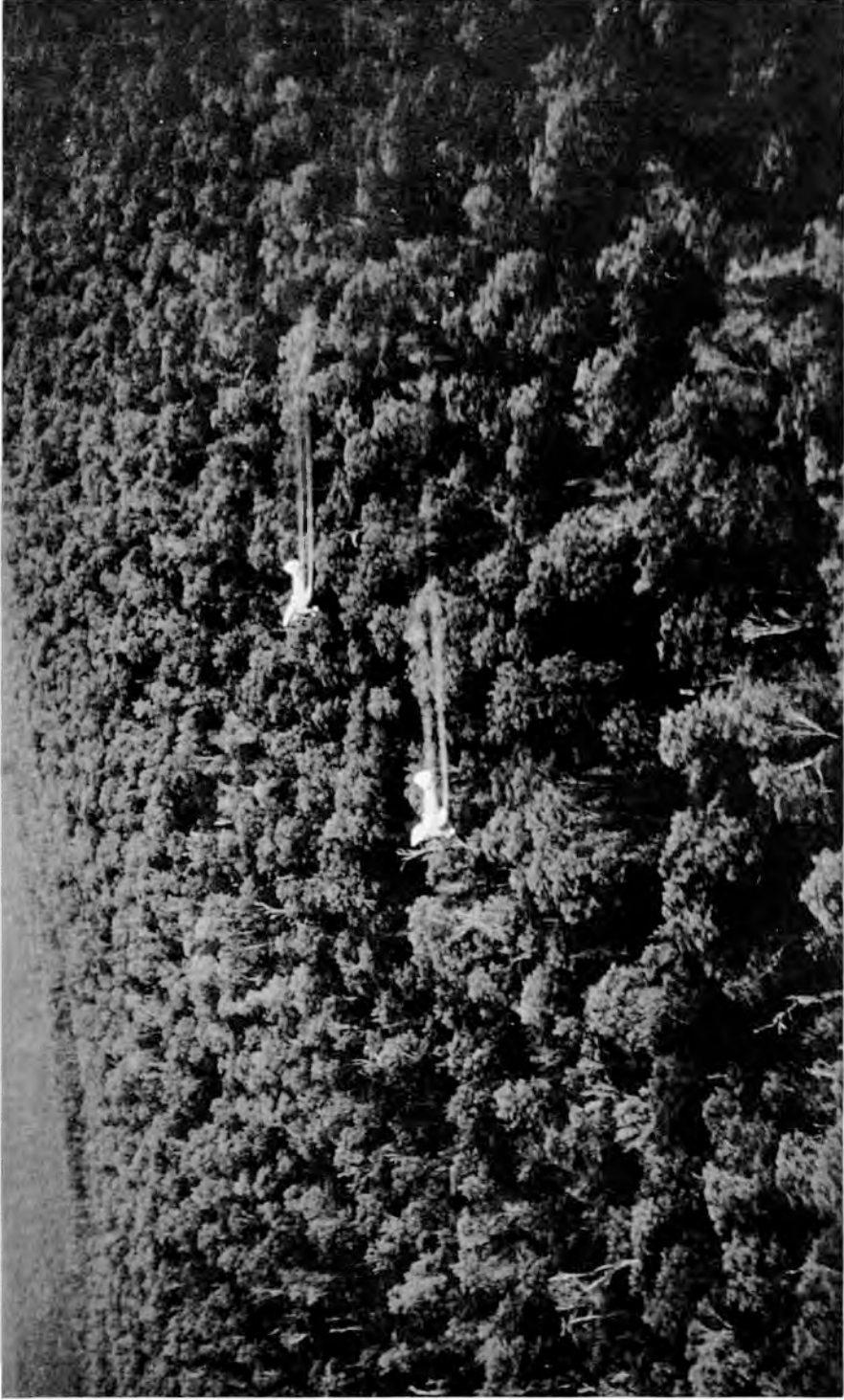

Plate 3. Crooke, Canada: Aerial spraying against spruce budworm in northern New Brunswick. Note high proportion of hardwoods in this mixed stand.

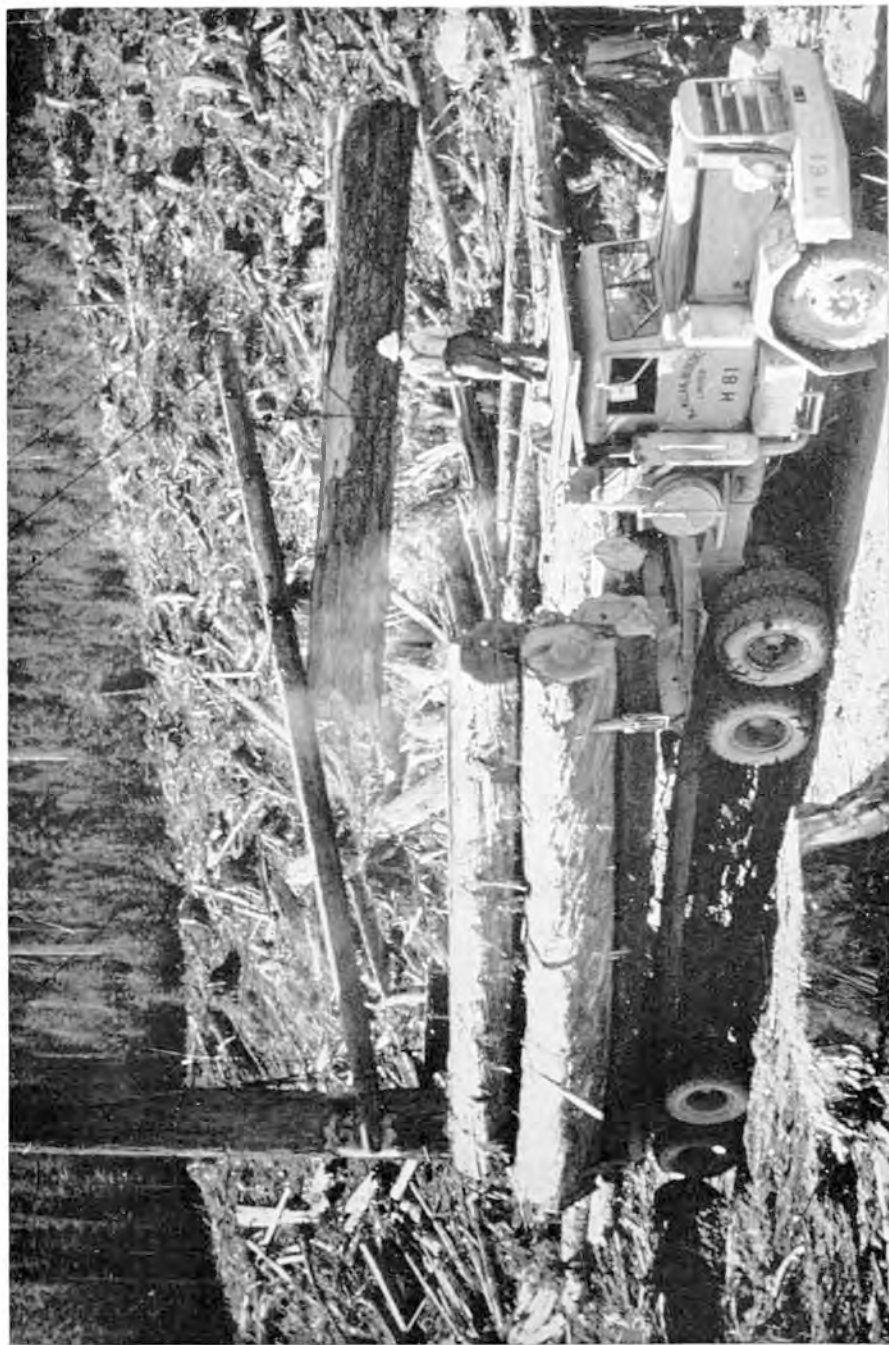

Plate 4. Crooke, Canada: Big logs of Douglas fir and western red cedar being loaded for extraction from "patch" felling site. Vancouver Island, British Columbia.

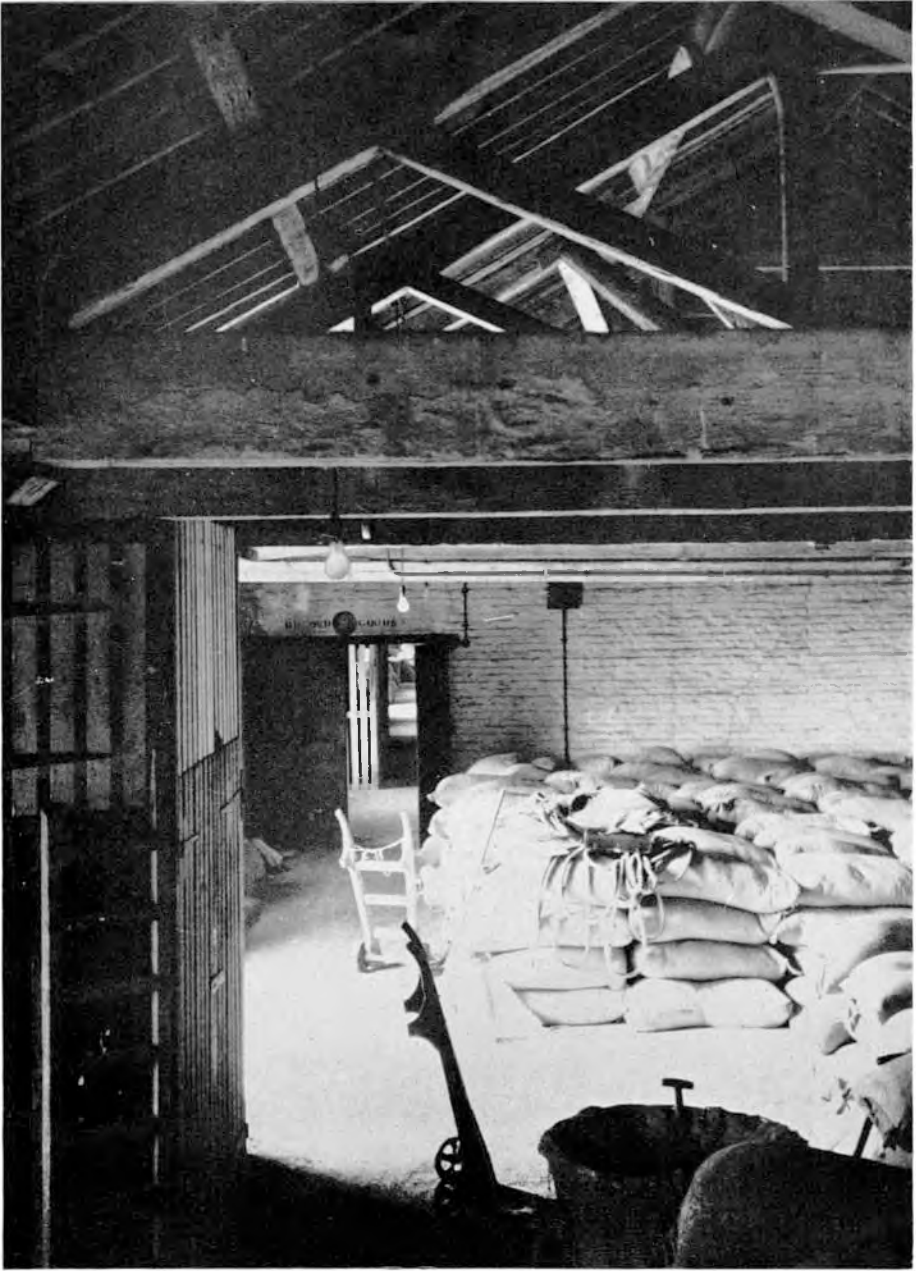

Plate 5. Aaron, London Docks: Roof trusses in home-grown Scots pine in No. 4 Warehouse, erected between 1803 and 1805.

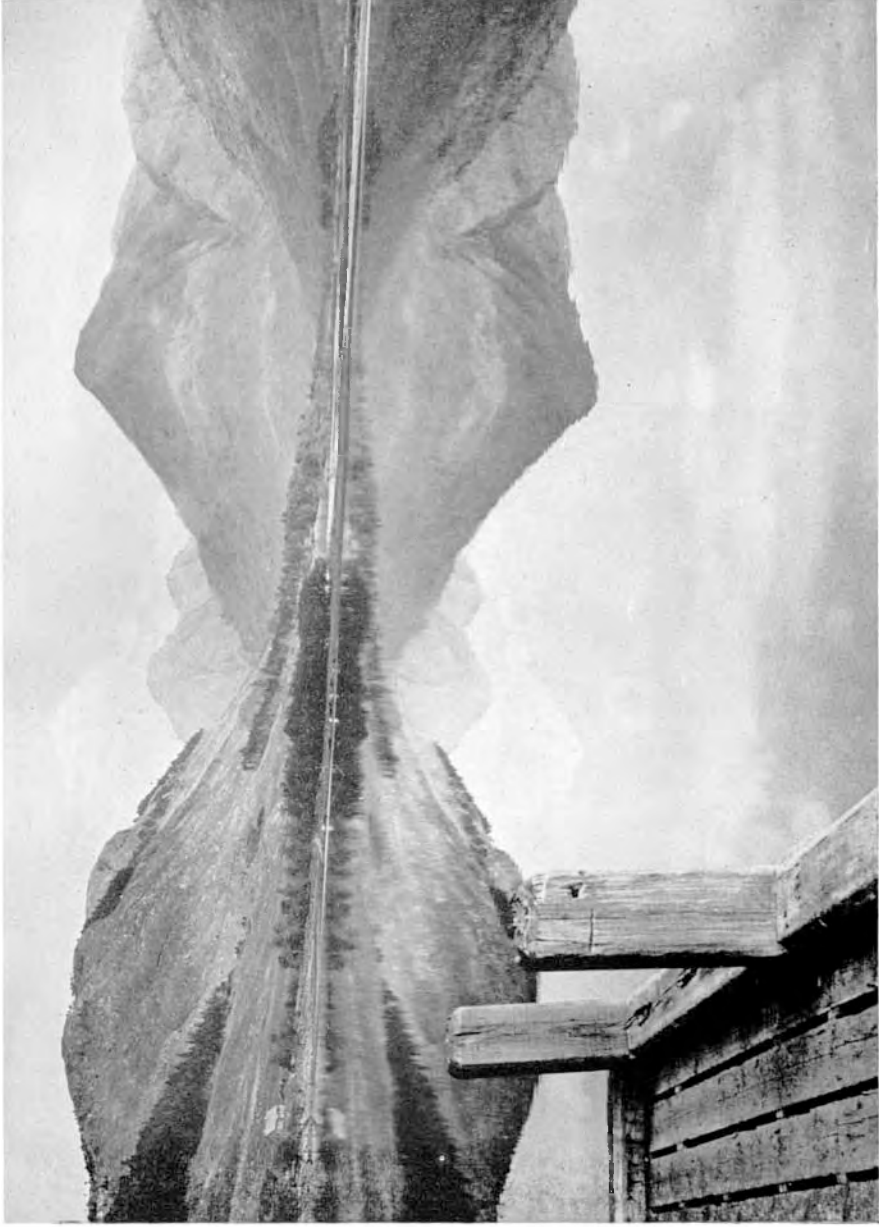

Plate 6. Graham-Campbell, Scottish Acquisitions: Loch Etive and the Commission's new Glen Etive Forest in Argyll. Glen Etive House lies on the left, Stob Dubh on the right, and the Buchaille Etive peaks beyond.



Plate 7. Hampson, Wild Goats: Forester Jones and his wild nanny goat at Abergynolwyn, Dovey Forest.



Plate 8. Hale, Alice Holt: The giant wild cherry tree or gean, *Prunus avium* growing in the Dyke at Alice Holt Lodge.



Plate 9. Packwood, Fire Tower: Details of the basal support of one main pole of the new Emery Down Tower.



Plate 10. Packwood, Fire Tower: The new wooden tower at Emery Down, New Forest.



Plate 11. Watson, Log Chalet: Notching the Logs.



Plate 12. Watson, Log Chalet: Cutting a door opening.



Plate 13. Watson, Log Chalet: The building finished to wall height.



Plate 14. Watson, Log Chalet: Building the rear gable.



Plate 15. Watson, Log Chalet: Caulking with rope.



Plate 16. Watson, Log Chalet: The finished chalet at Symonds Yat, Forest of Dean.



Plate 17. Small, Creosoted Sliding Gate:
Arrangement of split rail runners at ground
level, forming a groove for easy sliding.



Plate 18. Small, Creosoted Sliding Gate:
Alternative use of peeled poles as slides.



Plate 19. Small, Creosoted Sliding Gate:
Flat sill at ground level.



Plate 20. Small, Creosoted Sliding Gate:
Close-up showing close fit of gate to posts,
essential to make it rabbit-proof; also iron
hook used to keep it closed.



Plate 21. Blankenburgs, Divider: Using the divider to measure the length of a road in Kielder Forest.



Plate 22. The Commission's prize-winning Log Sulky on trial at Alice Holt.

The uses of forestry saws and their maintenance are fully discussed and explained. All the operations and tools required are admirably illustrated in detail, and there are about 200 small line drawings and also half-tone illustrations.

The reasons for peg tothing and raker tothing; which type makes a saw more aggressive, and how varying tooth distances reduce vibration. One saw calls for experience in sawing technique, and another, with the teeth leaning slightly backwards, making the saw less aggressive and so easier for beginners to handle.

Cross-cut saws—one-man and two-man—and the methods that reduce the weight of a saw and make for good balance and flexibility. Saws with the tooth line curved, which makes only a few teeth cut at the same time, and these teeth being pressed deeper into the wood make the sawing more efficient. Hollow and straight back saws, height difference of raker teeth and bevel filing. Symmetrical and asymmetrical tothing, moderate setting, a narrow kerf and low power consumption.

Saws with shorter length blades for heavy construction work and requiring pressure for feeding them into the wood; saws with the special tooth shapes preferred mostly in tropical climates.

Bow Saws and Blades

A very old saw type—the bow saw—probably the most improved during the past 50 years, which is used for almost every kind of forestry sawing, and has a blade that is easily exchangeable.

There is a little trick worth mentioning should a bow saw blade “run” or cut crookedly. If the blade in itself runs a little and the frame, at the same time, is slightly out of adjustment, the two faults could result in marked uneven running. Remove and turn the blade, then fit it again so that its other end is forward: thus the faults might counteract each other, resulting in an almost straight cut.

Frames

Among the many illustrations is a picture of a test machine for bow saw frames with a chain registering about 400 lb. which is about twice as high as the normal blade tension. It is the high tensioning power of these saw frames that allows the use of very narrow and fast cutting saw blades. Then the problem of re-sharpening bow saw blades arose.

Razor-Blade Principle

Courses for forest workers were tried, also another scheme whereby the workers left their saws to be filed by trained personnel. Newcomers to forestry later started to use the blades on a “razor-blade principle”, that is, they used a blade while it cut reasonably well. When it became unserviceable they threw the blade away and bought a new one—*these workers paid for their own blades!* At this stage research came into its own. Attempts to produce a cheap replacement blade reduced the quality below an acceptable level. Finally, after experiments and long-time tests, the so-called “hard-point hardening” process resulted. A Hard-Point blade will cut about three times as much wood as a conventional blade, without needing re-filing.

Filing is made obsolete, the cost of files and other maintenance tools is considerably reduced. The wear of the file alone in two re-sharpenings corresponds, it is said, to the difference in price between a conventional blade and a Hard-Point blade.

Maintenance Tools

Instructions are given on maintenance problems and how best to overcome difficulties, and the methods prescribed are clearly illustrated in dozens of line drawings.

Why does a saw cut badly? Why does it jump? What are the qualities of a good saw?

A couple of useful tips may be mentioned: files stay in good condition longer if, once in a while, they are cleaned with a wire brush or rubbed with a piece of charcoal. Friction between the saw and the wood steals a considerable amount of power, so to prevent rusting (if the saw is put aside for a couple of days) try rubbing it with an oily cloth. Keep the carton it was packed in, for it is an ideal guard when a saw is put away for some time.

Filing

A complete instruction course on filing is given, starting with, "File in good light only, daylight is best", followed by many pages of details covering every operation, with methods and the tools all so clearly set forth and beautifully drawn that success would seem to be inevitable.

Of course a saw can be filed by different methods and still the result would be good. The advice given in this booklet is based on the practical experience of Sandvik's own saw doctor, who is the originator of the manual, and from whom more than 20,000 forest workers—boys and veterans—have learnt saw filing at his courses. The booklet, indeed, contains all that the sawyer and the saw doctor could desire to know about saws; their care, maintenance, and efficient and effective use.

This interesting, instructive, and most useful booklet, strongly bound in an attractive, coloured cover, is a free issue, despite the fact that it was expensive to produce. Copies may be obtained free of charge, at least for the time being, from Sandvik Swedish Steels Ltd., Manor Lane, Halesowen, Birmingham.

H. JOHNSTON

Publications Branch

A NEW QUARTER-GIRTH TAPE

Contributed by Work Study Section

- (1). Two sources of error in quarter-girth tapes are:—
 - (a) Those due to the construction of the tape; stretching or illegibility due to accumulation of resin and dirt.
 - (b) Those due to the system of marking on the tape and the need to round down. When one reads a quarter girth of 4—3 the figures actually in the 'box' against the toggle are a black 4 on its side and a red 5! If you put the tape round from the right the five is upside down!

(2). A new tape has been designed and will shortly be placed on the market to eliminate or reduce these sources of error. The main changes are:—

- (a) The material of the tape has been altered to give more constant length, and a plastic coating added to improve resistance to dirt and resin. The tape is easily cleaned in water, using a detergent if necessary.
- (b) The numbering has been altered so that one can read off directly the rounded down quarter girth, as shown in Fig. 35.

OLD

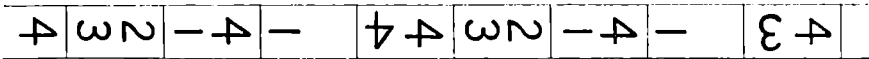

NEW

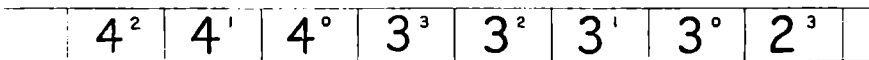

Fig. 35. Old and New Quarter-Girth Tapes.

- (3). A comparison of the two types will show that with the new tape:—
 - (a) The numbers used are those called, e.g. Four-three, Two-one, Five-oh.
 - (b) The numbers refer to a 'box' rather than a line and are placed centrally in it. *If exactly on a line the higher number is correct.*
 - (c) If the tape is passed round the tree with the right hand the numbers always come upright.
 - (d) If the tape is accidentally twisted once, the figures show black on red or vice versa.
- (4). A trial of this tape is strongly recommended. It should be impressed on anyone given the tape that:—

THE FIGURES ON THE NEW TAPE REFER TO THE SPACE BETWEEN THE LINES AND THAT IT GIVES THE ROUNDED DOWN QUARTER GIRTH DIRECTLY.

SHORT SHAFT AXES

Contributed by Work Study Section

- (1). At present all felling axes, whether of English (rounding axe) or Canadian (wedge axe) pattern, are supplied with shafts 36 inches long. Observation showed that many experienced fellers shorten their shafts, either by cutting off the last few inches of the handle, which is dangerous as the axe can fly out of the hands in wet weather; or by setting the head lower than intended, sometimes even below the shoulder of the shaft.
- (2). While making time studies on thinning operations the reason for shortening the shafts became obvious. Sawing is a better way of felling trees than axing and the axe is only used in felling for a very small part of the time, while laying in before sawing, or in cutting the hinge after sawing. These are the only times when the axe is swung at the full length, and even

then movement is often restricted by other trees or branches. When trimming or snedding begins the feller shortens his grip on the axe and from then on, for perhaps half of the total day's work, the last six inches or so of the handle are simply an obstruction to his freedom of movement.

- (3). Tests by over forty fellers during the past year have led to almost all of them adopting 4 to 5 lb. axes with overall lengths of 27 to 31 inches.
- (4). Certain manufacturers have now agreed to fit or supply shorter axe shafts to the following specifications:—

For English axes (rounding axes) of 4 lb. and 5 lb., 30 inch fawn foot handles to fit eye size $3\frac{1}{4} \times \frac{13}{16}$ inches.

For Canadian axes (wedge axes) of 4 lb., $4\frac{1}{2}$ lb. and 5 lb., 30 inch fawn foot handles to fit eye size $2\frac{1}{2} \times \frac{13}{16}$ inches.

(The dimensions at the shoulder of shafts supplied as spares should be $3\frac{1}{4} \times \frac{13}{16}$ inches and $2\frac{3}{8}$ inches \times 1 inch respectively. 30 inch shafts, when fitted will give an overall length of $28\frac{1}{2}$ to $29\frac{1}{2}$ inches.)

- (5). It is strongly recommended that all fellers working on coniferous thinnings up to 3 to 4 hoppus feet be given the opportunity to try out these short shaft axes. Men using 6 or 7 lb. axes should be encouraged to try a short shaft 5 lb. axe; men already using lighter axes should be loaned short shaft axes of their own preferred weight and if they like them, should then be supplied with shafts to fit their own axes.

LONG HANDLED FELLING TONGS

Contributed by Work Study Section

1. In some crops the most difficult operation during thinning is getting the poles down, after the actual felling with axe and saw has been completed. Many methods are used at present, carrying the tree down bodily, by hand, on a sack, or hooked on the axe, or by levering. Though effective these methods generally involve very heavy work and in some cases the risk of injury.
2. A new tool has been designed to assist in pulling the trees down. Basically it is a pair of scissor tongs to grip the butt attached to a handle. Once a good hold is obtained on the butt the tree is first heaved off the stump and then pulled away until the tree falls. See Figures 36 and 37.

Note correct position of body for pulling, straight back and arms, bent legs; one heave and its off (and mind your toes).

3. Other features are:—
 - (a) Two-handed grip so that two men can pull on very large trees, a tree of about 8 hoppus feet is the largest that can be handled.
 - (b) Short grip handle for manoeuvring over stumps, ditches or other obstructions.
 - (c) The tongs can be used to collect poles into tushes for extraction or for extracting by hand over short distances.

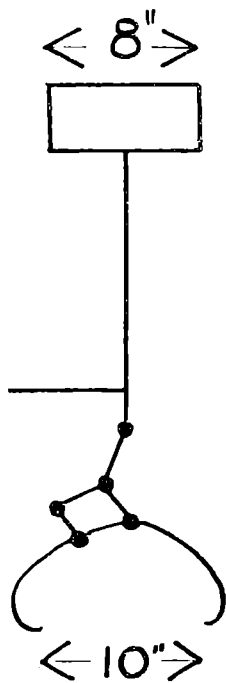

Fig. 36. Design of Tongs.

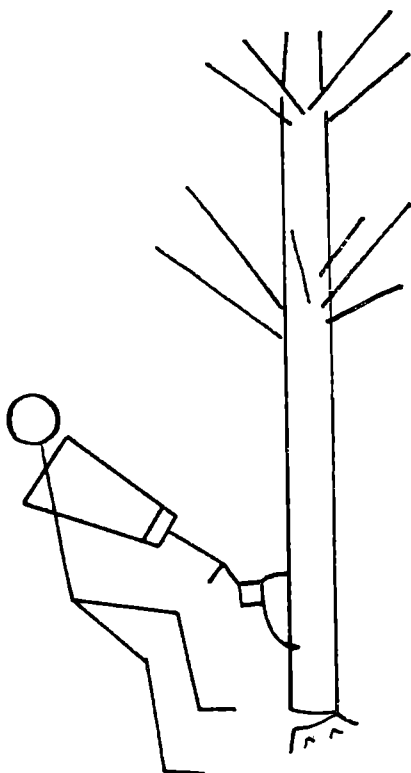

Fig. 37. Using the Tongs.

4. Trials of these tongs in various parts of Britain have shown that they are a 'specialist' tool not needed in most thinnings where the majority of trees fall freely or are easily pulled down. The tongs are of real value however in conditions which may be defined as:—

THINNING AVERAGING BETWEEN $1\frac{1}{2}$ AND 4 HOPPUS FEET IN CROPS WHERE VIRTUALLY EVERY TREE LODGES, AS IN MANY STANDS OF SITKA SPRUCE.

LOG REFRESHMENT CHALET AT SYMONDS YAT ROCK

By F. WATSON

Head Forester, Dean Forest

Early in 1956 it was decided to erect a Refreshment Chalet at Symonds Yat on the style of a log cabin. The Chalet to consist of a covered verandah with a sixteen foot serving counter, display and stock section and behind this a kitchen and storeroom. Material for the construction to be poles obtainable from a normal thinning carried out during the previous November of forty-year-old *Thuja plicata*.

It was felt desirable to have all poles used in building this chalet to be of equal size with a uniform taper, as this should simplify construction as well as enhancing the appearance of the completed chalet; poles of eight inch butt, with a six inch top diameter were decided upon.

In selecting these poles it soon became apparent that a half inch deviation from both butt and top sizes would have to be accepted, this did not present any difficulties in the constructional work. The selected poles were cross-cut to the desired lengths, tushed out to a suitable level site and placed on dunnage ready for peeling and dressing, where they remained to dry out for a little over four months.

Peeling commenced during March. Only poles from which the bark came away quite easily bringing the bast with it were dealt with; the remainder being peeled a week or two later when they had reached this condition. It was usual to prize up a three or four inch wide strip at one end of a pole and tear off the bark in long strips of up to ten feet before a break occurred. All knots were trimmed flush and swellings dressed down.

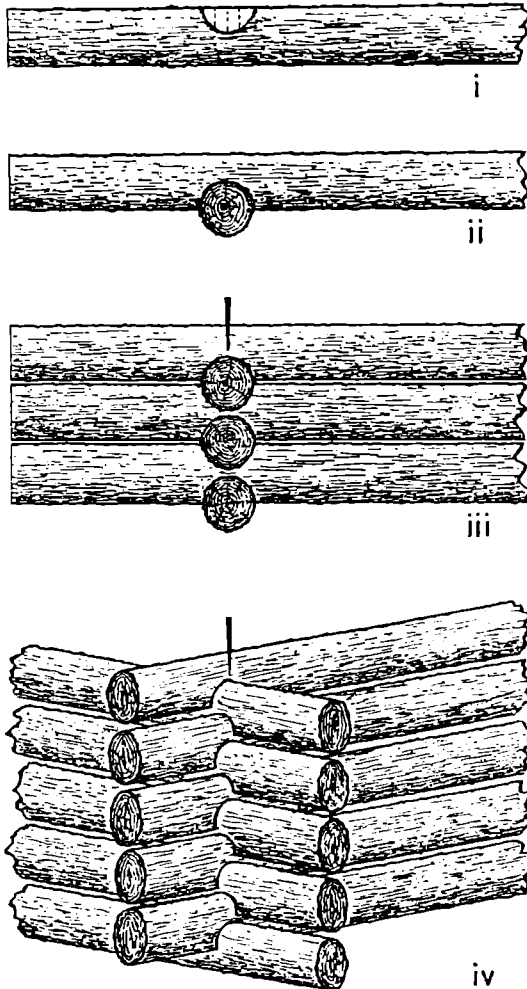

Fig. 38. Joints for Log Cabin Construction.

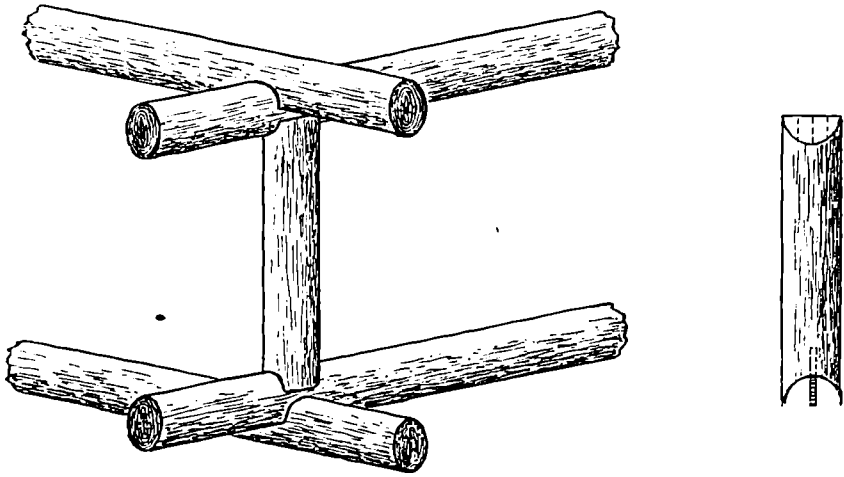

Fig. 39. Detail of Verandah Construction: A.

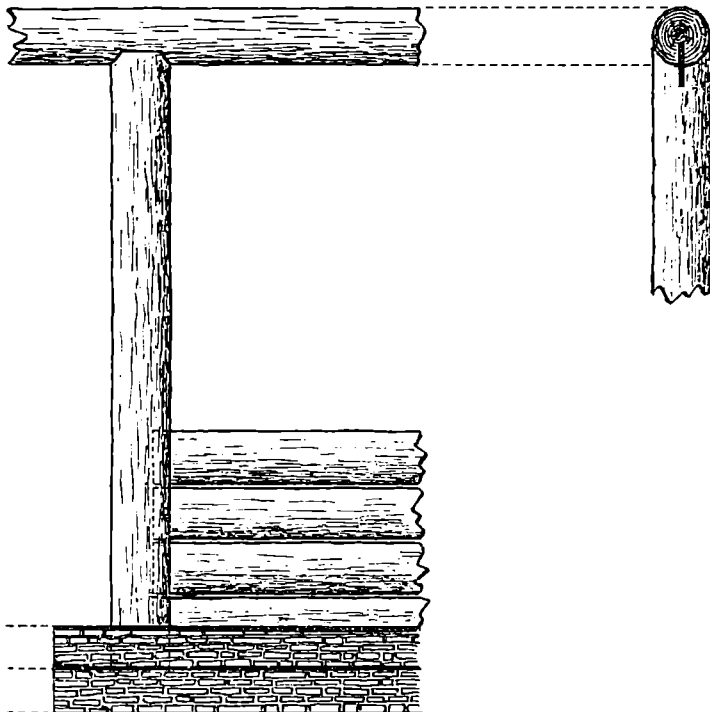

Fig. 40. Detail of Verandah Construction: B.

axed in line with the slope of the template. A half-inch hole was then bored perpendicular three feet from each end of the pole through which a fourteen inch bolt inserted upwards would secure the pole above, this second pole being already bored with four half-inch holes, two of the holes to receive the bolts already in position in the bottom pole, the remaining two holes to take the bolts which would receive the pole above. This second pole was then axed to the required slope and bolted to the one below; this procedure was repeated with each pole until the gable had reached the required height. Throughout this work gaps between all poles were correctly spaced with wooden wedges. The gable was then dismantled and taken up pole by pole and placed in position, caulking rope being placed along each gap before each pair of bolts were tightened down. As the completed gable had a tendency to sway, a couple of scaffold poles were lashed to each until they were secured firmly by the two purlins, the scaffold poles were then removed.

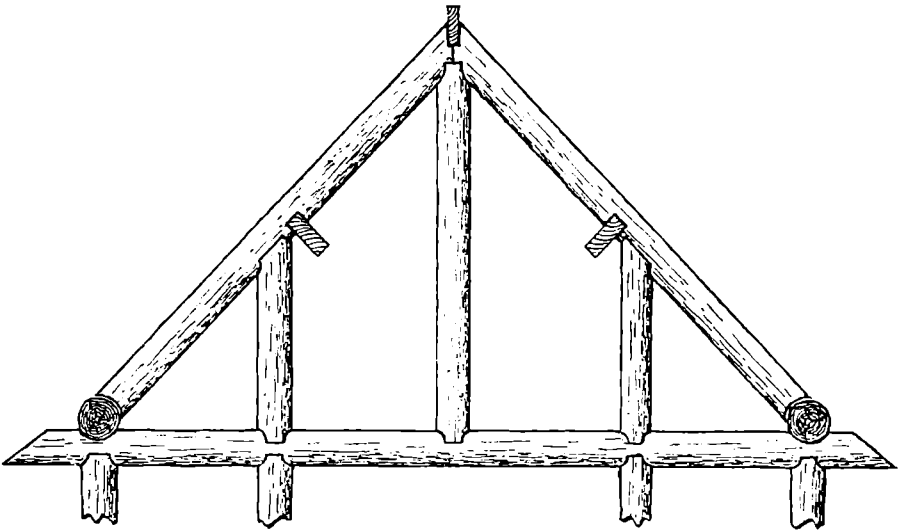

Fig. 43. Building an Open Gable.

The gable at the front of the chalet was of a different style; in order to let as much light as possible into the verandah, this consisted of a triangle constructed of poles similar to those used in the chalet walls. (See Fig. 43.) A pole placed along the top of the four front posts, which had been end-notched to receive it, would form the base of the triangle. Two shorter poles formed the sides at a similar slope to the two solid gables; three evenly spaced uprights supported these, the centre and longest one taking the bearing of the apex of the triangle where all three were bolted together. The main walls now completed, the structure was ready to receive the roof of cedar wood shingles, these being nailed to battens which had been fixed across the roof rafters. These rafters, two feet apart, were supported by the two purlins and wall plates, the roof to have an overhang of two feet. As the chalet had to be weather-proof, caulking of gaps between all poles with half inch caulking rope was necessary.

Starting at one corner, the end of the rope was wound tight, then pushed into the gap along the pole to the next corner, and driven in firmly with a three inch wide wooden wedge and mallet. When all gaps had been firmly caulked, the main structural work was complete, the projecting log corners were sawn

straight and in line using the straightedge again, the logs were all treated with a well brushed-in dressing of linseed oil.

The interior walls of the kitchen, storeroom and display section were of plasterboard, the log walls were lined with this material. The rear wall of the display section was fitted with shelves, also a doorway and serving hatch from kitchen (Fig. 44). The serving counter top was of "Bearite" in one piece, sixteen feet long by twenty-six inches wide and three-quarters of an inch thick.

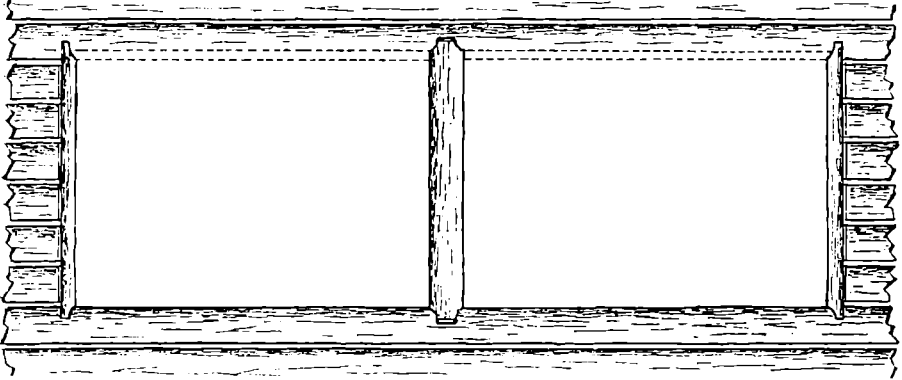

Fig. 44. Construction of Serving Hatch.

When the chalet is closed a metal roller-type blind with a lock on the inside shuts off the counter and other rooms from the verandah.

Two hundred and eighty-seven cubic feet of thuja logs were used in building the chalet; caulking of the structure required one and a half hundred-weights of caulking rope.

The overall size of the chalet is twenty-seven feet four inches by twenty-two feet eight inches. Photographs showing various stages of construction and also the chalet on completion, appear in Central Inset, Plates 11 - 16.

A CREOSOTED SLIDING GATE

By D. SMALL

District Officer, East England

The expression 'close the gate behind you' becomes increasingly difficult in these days of mechanisation and the annoyance and frustration that must be frequently experienced by all constant users of 'lift gates' has prompted the author to study a method whereby this frustration might give way to pleasure in a new method of 'closing the gate behind you'.

The remedy is simple and not new—it is to make it slide. It is not uncommon to see lift gates made out of pine poles, so old that they crumble and break to pieces, or alternatively made so well and out of heavy oak or larch that they take a good deal of strength and experience not only to open but to close them again.

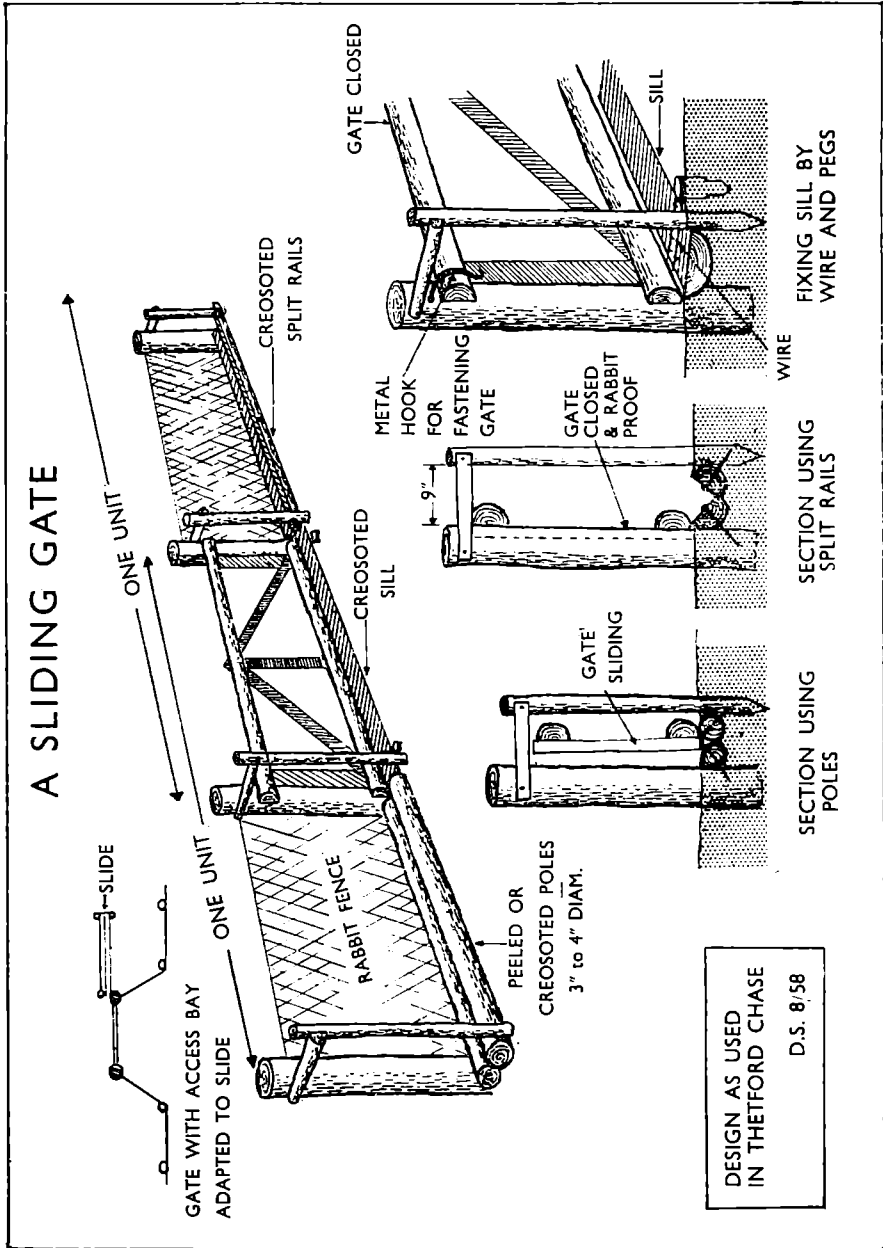

Fig. 45. Construction Detail for Sliding Gate.

The author's experience in the many uses of creosoted split rails of pine, prompted the thought that all materials for a gate were available.

The main theme of this design is simplicity and practicability in the field. Figure 45 shows that what is required is as follows:

- (1). 5 × 10 ft. 6 in. × 3 in. diam. split rail creosoted.
 - (2). 3 × 5 ft. 6 in. × 3 in. T.D. creosoted stakes.
 - (3). Some wire and nails.
 - (4). 2 iron hooks or 1 lift gate hook.
- (1). The gate is made up of 2 parallel 10 ft. 6 in. rails, held apart by 3 vertical and 2 diagonal pieces of split rail, i.e. 3 verticals make up 1 × 10 ft. 6 in. rail and 2 diagonal another 10 ft. 6 in. rail. These are nailed and covered with rabbit wire. Presuming that the gate posts are already in position, it is important that the gate is so constructed so that the 2 outside verticals make close contact with the gate posts when closed.
 - (2). One 10 ft. 6 in. rail is buried at ground level between the gate posts, and slightly outside fence line, to give a good flat side. This is secured by 2 short pegs and nailed across with fencing wire and staples.
 - (3). Two split rails *or* 2 branch-free peeled poles are laid outside the fence line to provide a smooth runner for the gate, and nailed diagonally to the gate and fence post.
 - (4). Two 5 ft. 6 in. creosoted stakes are driven in, just far enough away from the gate posts to allow gate to slide in between them, and prevent it from falling. These may be held by 2 small pieces of wood to gate post.
 - (5). One stake should be driven, the thickness of the gate from the fence, in at the end of the runner to hold the gate whilst open. Finally one hook that normally holds the lift gate, can be used so that when the gate is pushed to close, it engages the hook and holds the gate closed. A drop iron hook can also be used, when attached to the gate post.
 - (6). The drawings show in detail the method of constructing, and the inset shows where an entrance bay exists, the runners are laid out in line with the side.

It has been found that heavy lift gates can be converted simply and economically and provide an essential and efficient gating that is required in forest protection. These gates are made ready for use at Thetford Creosoting Plant.

Photographs, showing alternative use of split rail runners for easy sliding, and peeled poles as slides; the Small Creosoted Sliding Gate flat sill at ground level; also the close fit of the gate to posts making it rabbit-proof, appear in Central Inset, Plates 17 - 20.

DWELLING HOUSE MADE FROM THINNINGS TIMBER

By C. D. BEGLEY

District Officer, Utilisation Development Section

The disposal of small roundwood in the form of softwood thinnings at present comprises almost all the marketing activities of the Forestry Commission and of those who buy our standing timber. This applies to a lesser degree only, to the private grower. Looking to the future, more and more of our timber will be sawlogs. Since the building trade is the biggest single user of sawn softwoods, future developments in utilisation will involve a gradual extension of

sales of home-grown softwoods into the market for building timbers now supplied almost exclusively by the importers. A small quantity of home-grown sawn timber is already reaching the building trade but it will be some years before this volume assumes appreciable proportions. However, the problems likely to be involved must be studied in advance even though it involves using timber sawn from relatively small thinnings.

As part of these studies a small timber building was erected at Santon Downham in 1955. The building was a single-storied two-roomed office with Scots pine framing and Sitka spruce roofing members. The cladding was made of panels faced with 3-inch wide boards, 40 inches long, and cut from butt logs of thinnings from Scots pine, Japanese larch, Corsican pine, European larch, Sitka and Norway spruce and Douglas fir.

The timber has behaved well and with the experience gained a further building was designed, a two-storied three-bedroomed house, with a combined kitchen/living room and a separate parlour. One of the bedrooms and the bathroom are on the ground floor. The overall floor area was kept low at 830 sq. ft. in order to reduce costs; this was achieved by eliminating corridors, rather than at the expense of room area.

Virtually all the timber in the house was home grown with the exception of the staircase, window frames, and doors. The history of the timber from its ordering to its use in the building is worth following in some detail because, although it is a routine procedure throughout, it may be unknown to some foresters.

(1) From the architect's plans a bill of quantities was drawn up specifying the number of pieces of given length, widths and thicknesses required; all sizes were specified as fine sawn. It is important in all building practice especially where, as in this case, some degree of pre-fabrication is aimed at, that the material is accurately sawn.

(2) The timber was ordered from the sawmill in the following species and sizes, it being made clear that to allow for subsequent shrinkage after seasoning, the material must be cut slightly over-size from the green log.

- (a) External cladding— 3×1 inch strip wood in random length—Sitka spruce, Japanese larch and Scots pine.
- (b) Flooring— 5×1 inch boards for first floor and 4×1 inch boards for ground floor—Scots pine.
- (c) Panel framing and carcassing timber—mainly 3×2 inch Scots pine but also in sizes up to 6×2 inch.

(3) All this timber had a moisture content above 100% when sawn, and could not of course be used in this condition. It was sent to a commercial firm for seasoning by kiln drying. We were able to follow through the process of drying, learning something of the problems associated with drying small quantities of mixed species under normal commercial practice. The results were generally satisfactory but it is evident that with timber taken from small logs it is difficult to avoid "boxed heart" (the inclusion of pith in the wood) and that this type of timber is likely to require special care in kiln seasoning.

(4) The flooring, panel framing and carcassing were all treated with a waterborne preservative as these timbers are exposed to risks of fungal infection. Here again we were afforded an opportunity of following the process, and of finding out if there were any special difficulties associated with home-grown timbers. The preservative was Tanalith "C", a water soluble chemical of the copper-chrome-arsenate type. One of the snags we thought we might encounter was the "collapse" of the thin-walled spring wood, under the pressure

applied to force the preservative into the wood. This is more likely to occur when the pressure is accompanied by high treatment temperatures, but with this preservative treatment temperatures are, fortunately, moderate. There was, in the event, no trouble. However, a disadvantage with this form of treatment, is that the wood has to be re-seasoned. This meant, with our timber, that it was twice subjected to the rather exacting kilning process, not without some failures.

This experience has stimulated our interest in (a) improved methods of air seasoning prior to kiln seasoning to final moisture contents (b) a method of treatment with preservative that can be used with green timber. Work on both these projects is planned in co-operation with Forest Products Research Laboratory.

The house was erected by a contractor and no special skills were involved as there were no novel features in the design. Basically the framework consisted of a series of "panels" which are rectangular frames of varying dimensions, made mainly of 3 x 2 inch pieces and bolted together, vertically, to carry the cladding timber which constituted the walls and horizontally to carry the first floor and roof.

The house is now occupied by a forester of South-East England Conservancy. Plans are in hand for further developments of this kind.

TIMBER CONVERSION

By THOMAS HESP, M.Sc.Tech, F.I.M.Wood.T., F.I.W.Sc.

Manchester College of Science and Technology

The sawmiller picks up where the forester lays down, i.e., the felled log safely loaded on the particular mode of transport en route to the saw mill. Strictly speaking the term timber conversion is all-embracing and covers the initial breaking-down, its later resawing to a convenient section and its subsequent passage through a series of operations until it becomes a finished component. It is the writer's intention to deal mainly with the efficient and economical breaking down of the log and its conversion to a convenient square section, and no reference will be made to any planing or moulding operations.

For obvious reasons emphasis will be mainly on the breaking down of home-grown hard and soft woods though quite often some of the machines mentioned could also be used for cutting the much larger hardwood logs of tropical country origin.

The Round Log

It would be pointless in a journal of this character to state the trades' preference for straight, regular shaped logs; from 30% to 60% of the log's volume is inevitably lost (at least as usable timber) in conversion and this wastage is obviously related to shape and size of log, though patent and even latent defects, number, size and type of knots do affect this figure quite appreciably.

The sawyer does rely on the forester to see that the felled tree is not allowed to accumulate excess mud, grit and forest debris on the bark. Depending on the type of sawing machine used, and this point will be covered later on, an expensively maintained bandsaw blade can be virtually put out of action in seconds by contact with a stone or other hard substance secreted in the bark, and it is not always economical to debark a log before cutting.

There are two principal ways in which a round log can be cut up and these will be explained before the machines used for the purpose are described.

- (a) Through and through sawing, in which the log is dogged in one position on the saw carriage and the cutting is made in one plane repeatedly through the log. It is sometimes referred to as "plain sawn" or "slash sawn". See Fig. 46.
- (b) Quarter sawing in which the log is usually, though not always, cut into four quarters, the subsequent cuts are then made as nearly as possible along the rays of the log. True quarter sawing would involve too much waste to be commercially economic, because the boards would perforce be wedge-shaped; an approximation is usually accepted and is strictly termed "bastard" quarter sawn, see Fig. 47.

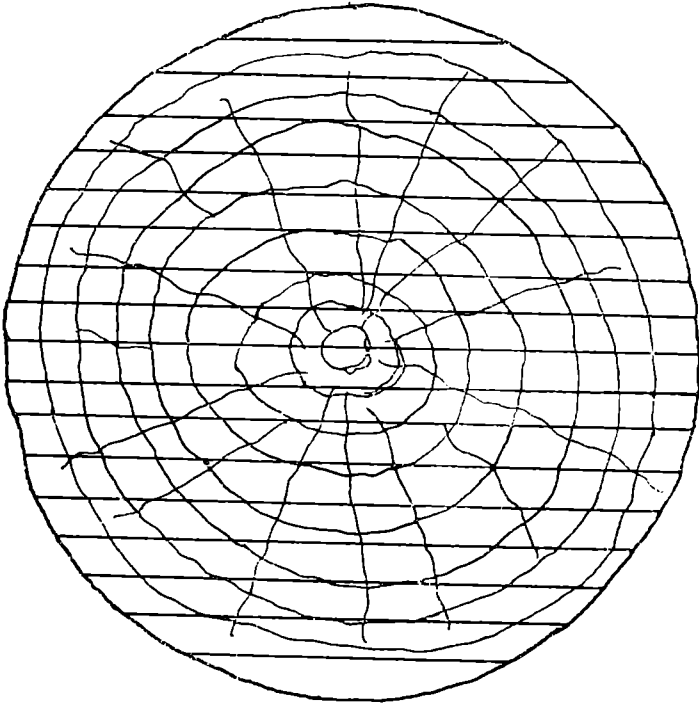

Fig. 46. Log Cut Through and Through, or Slash Sawn.
(Note: Centre Boards would be the same as Quarter Sawn).

By reference to Fig. 46, it will be seen that even in "through and through" cutting it is inevitable that a number of boards from the centre of the log will be, in fact, the equivalent of quarter sawn boards in that the flat sawn face is almost radial and the growth rings cross the face at almost 90°. It will be clear from the illustration that the method of converting shown in Fig. 46, is a much cheaper way of sawing than that shown in Fig. 47. In the first method, once the log has been dogged on to the carriage in the case of the bandmill, it is just cut through and through without any further handling. The second method involves a continual re-adjustment of the log or quarter, and the prospect of much more waste; the question naturally arises, why the necessity to produce quartered stock?

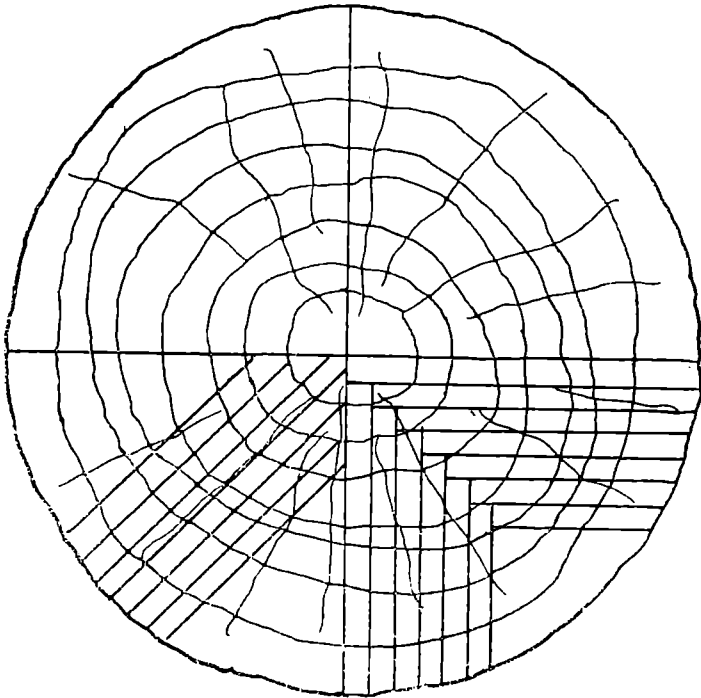

Fig. 47. Two Methods of Producing Quarter Sawn Boards.

At least three of the reasons are:

- (1) To produce a finer figure on the face side of the board so requisite in decorative work and particularly exemplified in good quality oak; the figure produced when oak is quarter sawn enhances its value immensely; it applies also to other decorative hardwoods.

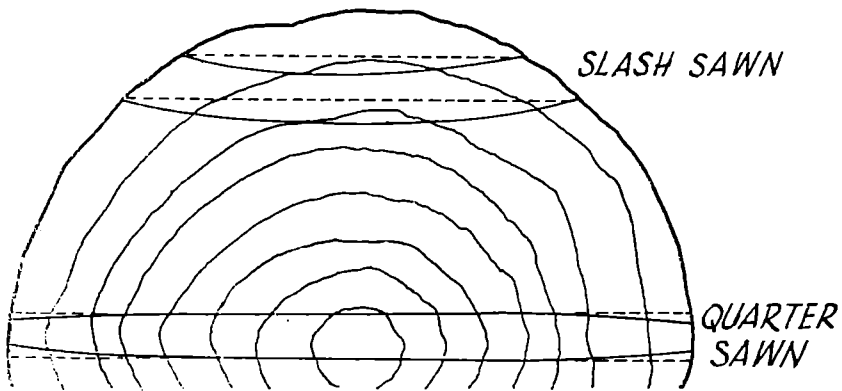

Fig. 48. Shrinkage of Timber from Different Parts of Log.

- (2) Plain or slash sawn boards warp and twist much more than when the same timber is cut radially; this is shown in Fig. 48. The maximum shrinkage, depending on the moisture content, occurs tangentially on

the lines of the growth ring and is much less in the radial direction. If it is intended to use the timber in comparatively wide widths it should at least be "bastard" quarter sawn.

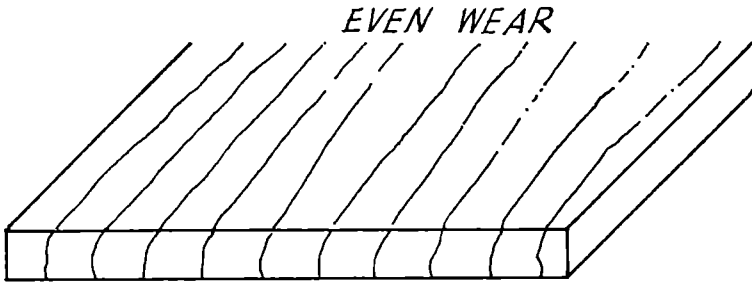

Fig. 49. Least Area of Soft Tissue Exposed by Quarter Sawing.

- (3) Fig. 49, explains the reason for having floor boards and blocks quarter sawn, (incidentally another name for this is "rift" sawn). When sawn in this manner the growth rings, which are composed of "early" and "late" wood, or alternating bands of soft tissue, are exposed on the *edge* of the board which is the surface not usually subject to abrasive wear. Where this surface is exposed it wears very unevenly as the soft tissue wears away much more quickly than the hard, thus leaving alternating high ridges with the soft tissue worn down in between. Exposing the radially sawn side of the board to the wear gives much greater resistance to abrasion, and wear in any case is even. Fig. 50 illustrates a board which has been slash sawn with the growth rings exposed on the wearing face; the alternating bands of hard and soft tissue will tend to pick up, as can be seen in the floors of older buildings where this type of board has been subject to wear.

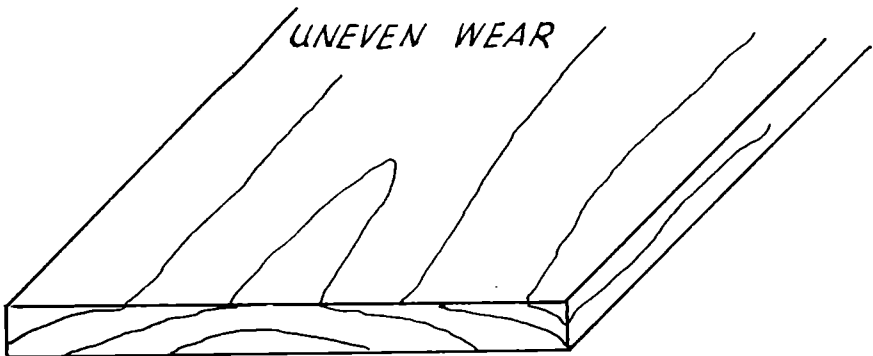

Fig. 50. Slash Sawing Exposes Large Areas of Soft Tissue.

Whilst log conversion is generally governed by the aforementioned factors, other conditions arise where the skilled judgment of the sawyer determines the way in which the log has to be cut. Quite a lot depends on the shape of the tree, a number, particularly in the English timber mills, are irregular in length and there may be certain obvious defects which he must try to eliminate during the cutting. He may have instructions to produce certain sizes, or to concentrate on a certain grade, all points which must influence his judgment. A log invariably tapers and the straightest grained timber would be produced when

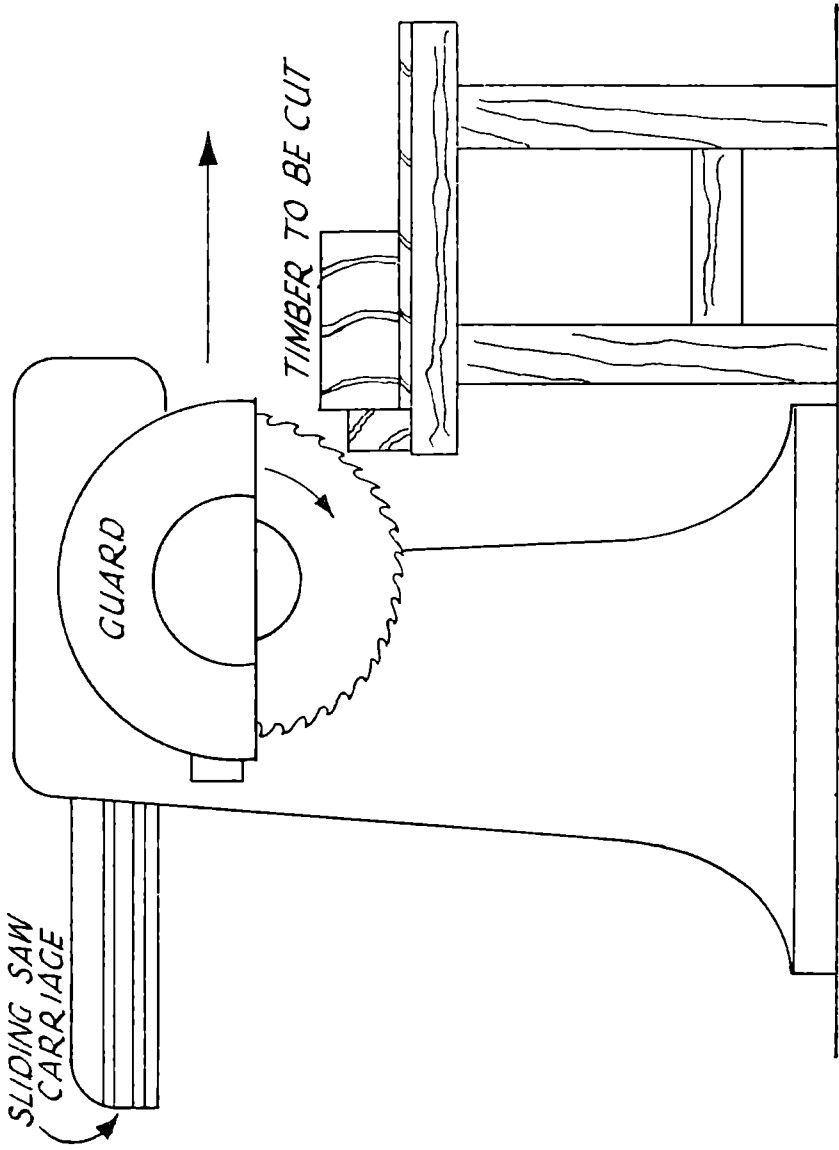

Fig. 51. Straight Line Pull-Out Crosscutting Machine.

the log is cut parallel to bark; for various reasons this is not always possible or expedient and he may be compelled to cut parallel to pith. These decisions are usually left to the discretion of the sawyer and are made in the light of his general instructions.

The first operation on arrival of the logs at the mill is to crosscut them to convenient lengths, mainly to ensure ease in subsequent handling but also to facilitate its conversion; an irregularly shaped and tapering log is much easier and more economically cut when reduced to its shortest length. Oak and elm can usually produce a large sound butt end and there is a large demand for wide coffin boards in these timbers, so the first lengths are often cut to 7 ft. app. for this purpose. The Douglas fir usually makes around 18 to 20 ft., a useful length for a structural timber, whilst the Scots pine and spruce work out a little shorter, again depending on size, shape and the lengths in popular demand.

For many years the electrically driven reciprocating crosscutting machine was used for cutting large round logs to length. A long saw blade, not unlike a double-handed crosscut saw, was caused to reciprocate through a crank shaft mechanism, and traversed through the log by the operator turning a handwheel working through a quadrant rack, the teeth cutting on the return stroke. This very useful machine now appears to be giving way to the much more versatile chain crosscut saw, and there are few native timber sawmills without at least one of these machines driven by a small but very efficient internal combustion engine. The use of a circular saw for this purpose appears to be on the wane, though certain machines are still available, they suffer mainly because the diameter of the saw must be twice the diameter of the log plus 9 to 10 inches, this makes it unwieldy and cumbersome.

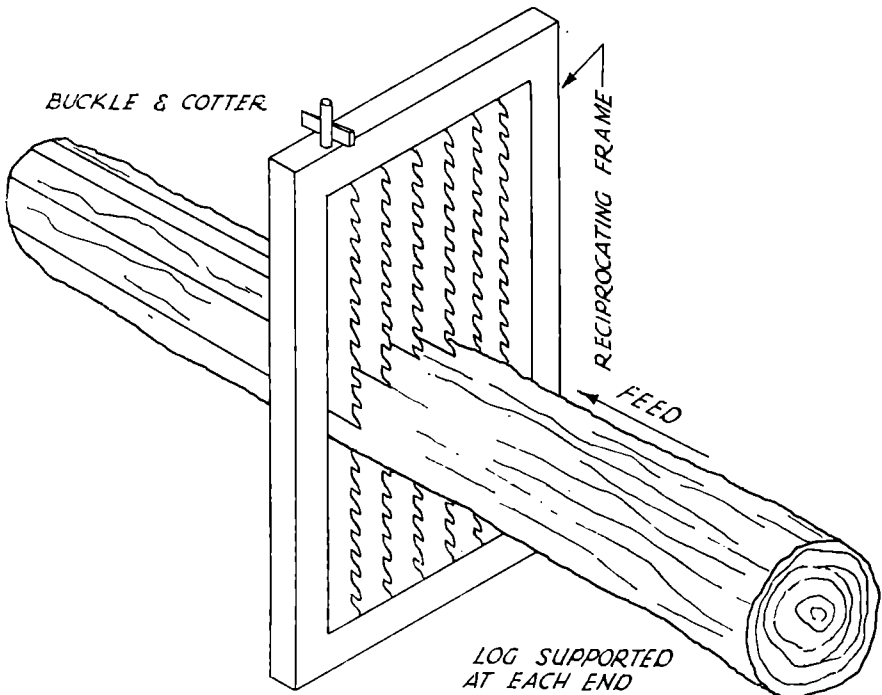

Fig. 52. Diagrammatic Sketch of Saw Arrangement in Vertical Log Frame. Vertical Pillar Omitted.

Crosscutting of the squared timber is easily accomplished by the use of the straight line, pull-out crosscut, Fig. 51, the successor to the now old-fashioned pendulum saw.

The Log Frame

In spite of the popularity of the now almost universally accepted circular saw and band saw, the first mechanically driven sawing machine was without doubt the single vertical frame saw. It was simply a mechanical version of the primitive pit saw, a long two-handed saw used manually for log conversion, with the log supported over a pit, one sawyer standing above the log and one within the pit. Accurate sawing demanded a high degree of skill from the sawyers and it is interesting to learn that this method is even yet in use in the more remote tropical timber-producing areas where access is difficult and native labour is comparatively cheap.

From the single vertical frame saw it wasn't long before the reciprocating frame was carrying not one saw but up to twenty, and it was thus able to convert a complete round log into through-and-through boards at one pass through the machine. (See Fig. 52.) True the feed speed was slow by modern standards, around two feet per minute for hardwoods to twelve feet per minute on softwoods, obviously depending on size. As it produced a number of boards simultaneously the rate of sawing was not as slow as it at first seems.

In operation the log is supported at each end on a light travelling carriage with gripping dogs, and fed through the frame by feed rollers; the carriage is automatically tripped as the cutting area is approached. Whilst this machine is still in vogue in the Baltic softwood producing countries, it has been almost entirely superseded in Britain.

Horizontal Frame Saw or German Saw

The horizontal frame saw, or the German saw as it is frequently called, is somewhat similar to its vertical counterpart except that the saw is disposed horizontally and caused to reciprocate in that direction by means of a heavy connecting rod and crank. It also differs in that it normally only carries one saw, though occasionally a double-saw version is seen, but certainly no more; it is thus a fairly slow method of conversion.

In spite of this it has a number of advantages such as:

- (a) Saws clean and accurately.
- (b) Log can be inspected after each cut and turned if it is considered necessary.
- (c) Little waste in saw kerf as the blade is relatively thin.
- (d) Saw blade requires very little skilled attention and is easily sharpened.

This machine incorporates a travelling log carriage mounted on rails; the log is dogged to the carriage which feeds it through the machine. As the blade reciprocates horizontally it is toothed in each direction from the centre, and thus cuts on both strokes.

Quite a number are still in use in Britain, especially in the older country mills, and a good case can be advanced for their retention. They will convert quite large logs, if somewhat slowly at least accurately and clean. It is a useful hack machine used in an ancillary capacity to a bandmill especially where metal is suspected within the log; the frame saw is easily sharpened but should an expensive bandsaw catch iron its repair is a very costly business.

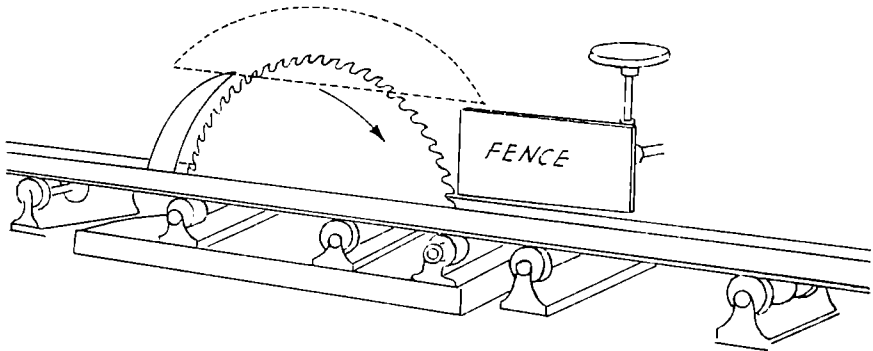

Fig. 53. Circular Saw Rack Bench. (Crown Guard Removed).

Circular Rack Bench

Fig. 53 depicts a circular sawing machine which is very common in English timber mills for the conversion of round native timber both hard and softwoods. It derives its title from the fact that the tables between which the saw cuts and upon which the log is placed for cutting, obtains its traverse from a "rack" or series of teeth fitted along the underside of the tables which engage with a pinion or toothed wheel attached to the driving shaft. This shaft is normally power-driven; but a few of the older type still remain in use in which the sawyer or his labourer drive the feed manually by means of a cranked handle.

The use of a circular saw for round timber conversion suffers from the fact that it can only cut with much less than half its diameter. It would take at least a 72 in. diameter saw to cut through the centre of a round log 30 in. diameter. A saw of this size would require to be very thick, around 7 B.W.G., (Birmingham Wire Gauge) which is 0.180 in. thick; this with the necessary set would make a saw kerf of $\frac{3}{16}$ inch, a very high wastage factor. Further a saw of this type loses diameter by repeated sharpenings, which not only reduces its maximum cut but reduces its peripheral speed, resulting in less efficient cutting.

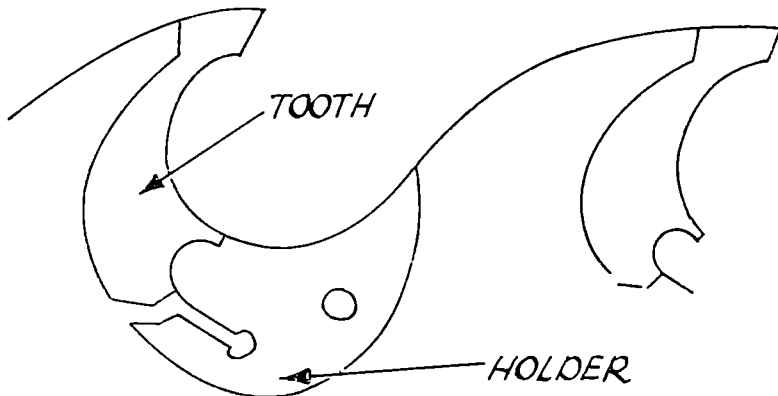

Fig. 54. Inserted Tooth Saw.

It is in fact these factors which have led to the introduction of the inserted tooth saw for this machine. Fig. 54. The heavy plate is machined to accommodate a series of detachable teeth which are located around the rim of the saw in holders. The teeth or bits are comparatively cheap and easy to replace, they

are sharpened *in situ* by filing, and when worn or damaged a new set is quickly fitted; thus the saw always retains its original diameter and its most efficient rim speed.

In the older and usually large type of rack bench the timber is held on the travelling table by its own weight; if in the round it is wedged to prevent it turning whilst being cut. But the more modern type now incorporates a number of swing hook dogs which effectively secure the log. In operation the log is laid on the table by crane or chain block and lined up over the division between the two tables which of course, is the line of the saw cut, round logs are wedged and the tables travel forward at a predetermined speed controlled by the sawyer. After the cut the off-piece is lifted off and the log is levered clear of the saw blade and the tables are returned at an accelerated speed ready for the log to be repositioned for the next cut. When two squared surfaces are obtained, subsequent cuts may be made with a sawn surface in contact with a guide fence, which may be locked in any position thus ensuring a particular thickness of board; such resawing would only be attempted with rough, low cost logs.

Due to the thickness of the saw kerf from these large circular saws this machine is often used just to square the round log, in which case the saw kerf can be located within the waste slab. Further resawing is then done on either a band or circular resawing machine.

This type of machine lends itself to easy erection and dismantling in clearings adjacent to the forest and for that reason is often used as a portable saw mill for forest operations.

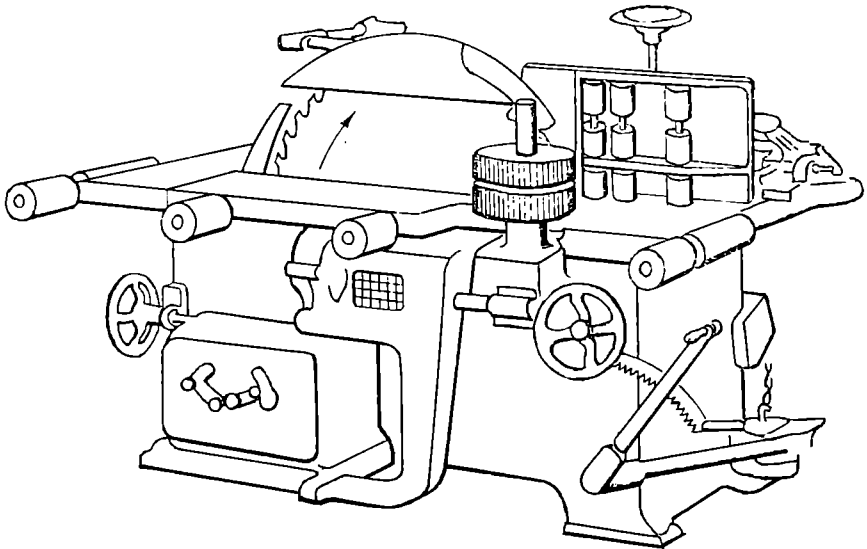

Fig. 55. Roller Feed Circular Saw.

Roller-feed Circular Sawing Machine

Whilst this machine is rarely used for actual conversion of round timber it has an extensive use in the resawing of timber which has been initially broken down on one of the foregoing machines, and it has a very wide use in the economical sawing to size of imported square timber. The modern machine of this type is an excellent engineering job and capable of a very high output. See Fig. 55. The most common machine of this design carries a 36 inch diameter saw

which will give a maximum cut of $13\frac{1}{2}$ inches, whilst the larger machine with a 42 inch saw will cut up to $16\frac{1}{2}$ inches.

The adjustable guide fence, the position of which determines the thickness of the board being cut, carries a series of anti-friction rollers let into its working face, the timber is fed forward through the saw, trapped between the rollers in the fence and a vertically disposed toothed feed roller. The feed roller, mounted on a telescopic arm to a variable speed gear box, has a range of feed speeds from 25 ft./min. to 160 ft./min., the speed chosen depending mainly on the depth of cut and the texture of the timber. If necessary the guide fence may be canted, so enabling diagonal cuts and bevel stock to be produced.

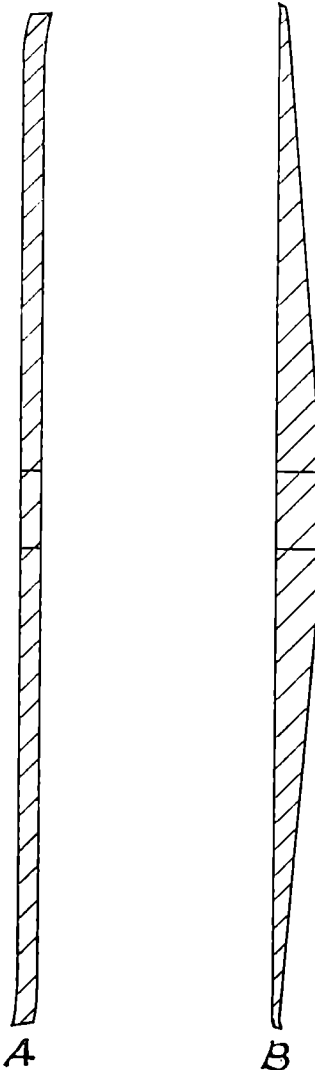

Fig. 56. Sections Through "A"—Parallel Platc. "B"—Swage Circular Saws.

Depending mainly on the diameter of the saw in use the wastage in saw kerf on this machine is much less than on the rack bench, but is rather more than on the band resawing machine. A 36 inch diameter parallel plate circular saw (see Fig. 56), would probably be 11 B.W.G. which is just under $\frac{1}{8}$ inch thick, but when spring set (Fig. 64) would make a kerf of $\frac{3}{16}$ inch, whilst a 6 inch wide bandsaw of 18 B.W.G. is just over $\frac{3}{8}$ inch thick and gives a kerf of only some $\frac{3}{32}$ inch.

Swage Saw

For deep cutting thin boards up to $\frac{3}{4}$ inch thick on the roller feed sawbench, what is termed a swage saw (Fig. 56) may be used with an appreciable saving in loss through saw kerf. It does in fact compare with the aforementioned bandsaw in this respect. It will be seen that it tapers in section, thick in the centre and thin at the rim. The saw kerf is determined by the thickness of the saw at the rim, hence the economy, but it is very limited in its application, obviously the cut board must be thin enough to curl round the thicker part of the saw. It is widely used in the packing case industry where there is a large demand for smooth, clean sawn boards from $\frac{1}{2}$ inch to $\frac{3}{4}$ inch thick, and for this type of work the swage saw is admirable. It will deep cut at a high rate of feed and leave an exceptionally smooth finish almost comparable with a planed surface yet with the very minimum wastage in saw kerf.

Bandsaws

Whilst the use of an endless toothed band of steel for cutting wood goes back about one hundred and fifty years, it was confined to light curvilinear cutting until just before the beginning of this century. It was then introduced as a much wider blade (6 inch as opposed to $1\frac{1}{4}$ inch) with consequently larger diameter wheels which were at first horizontally disposed for the breaking down of large round logs.

There are now three distinct types, i.e.

- (a) Band resawing machine.
- (b) Vertical log bandmill.
- (c) Horizontal log bandmill.

The band resawing machine is, as its name implies, designed expressly for resawing timber after it has been reduced and squared by one of the breaking down machines. Available in either 48 inch, 54 inch, and 60 inch size with saws between $4\frac{1}{2}$ to 6 inches wide, it has a lot in common with the circular roller feed saw bench previously described. The wheels are positioned vertically above each other and the timber is fed through the saw, trapped between a vertical feed roller and the anti-friction rollers in the surface of the guide fence.

It is not as restricted in capacity as its circular saw counterpart; the 48 inch machine will deep cut up to 24 inch with the very minimum of saw kerf. It is without doubt the most efficient and the most popular method of deep cutting wide stock. It does however require expensive maintenance of the saw blades, usually by a skilled saw doctor.

Horizontal Bandmill

The older design of the two bandmills has its band wheels disposed horizontally as depicted in Fig. 57, on a saw wheel frame which in turn is carried on a pair of vertical pillars. Both wheels are mounted on double row roller bearings and are accurately balanced; one is driven by an electric motor mounted in one of a number of positions, whilst the other wheel trails; the saw

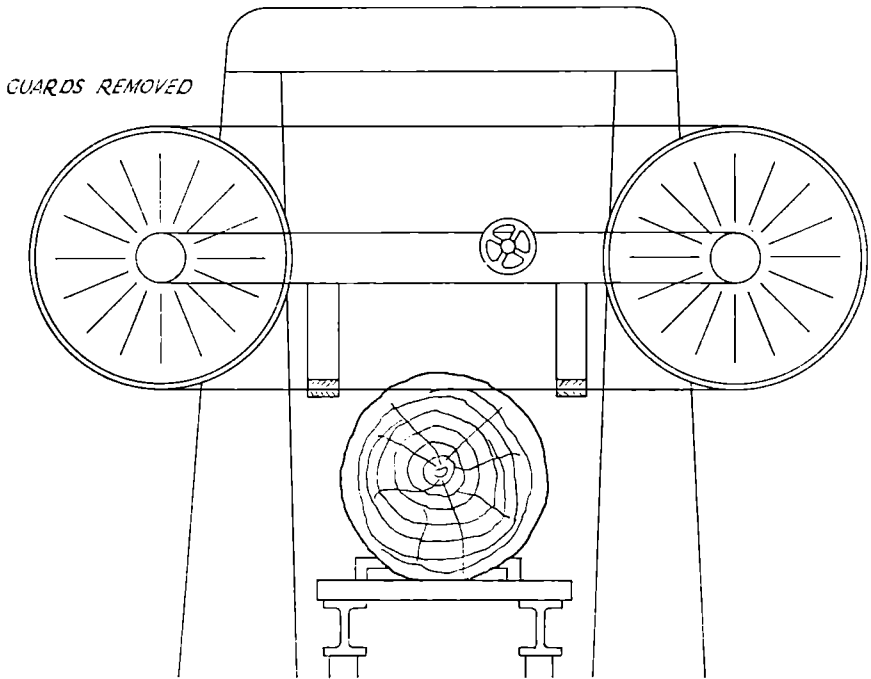

Fig. 57. General Arrangement of Horizontal Bandmill.

is strained tight on the wheels by adjustment of the trailing wheel. Saw guides, usually fitted with hardwood packings, are carried from the saw wheel frame—a pair either side of the log; they are instantly adjustable along traverse slides to ensure their correct location close to the entry and exit side of the saw cut in the log. The size of the machine is determined solely by the diameter of the saw wheels, which range from 84 inches in the horizontal to between 48 and 60 inches in the vertical.

The log is presented to the saw whilst dogged on a travelling log carriage. This carriage is built up of steel joists connected at intervals by sturdy cross ties. The travelling motion is imparted to it by two pinions driving a rack on the underside of the longitudinal joists. An easy motion of the travelling carriage is assured by idle rollers set in bearings either on wooden sleepers or direct on the concrete bed. Provision is usually made at the in-feed and out-feed ends of the machine for a carriage from 30 ft. to 40 ft. long.

Whilst assistance is normally required in loading the machine, dogging the log and removing the sawn stock, only one man actually operates the machine. Working at a control stand, a lever operates the vertical adjustment of the saw wheel frame, the thickness of cut being made is controlled by an ingenious rotary micrometer. Other levers control the forward motion of the carriage and its accelerated return. It is, of course, necessary to raise the saw above the log on the carriage before returning it to the in-feed end for repositioning it for the next cut.

Vertical Bandmills

The vertical machine is illustrated by Fig. 58. The main difference lies in the vertically disposed wheels which involve the lower wheel being within the

ground. The log overhangs its carriage and the log is automatically off-set after each cut and repositioned for the next cut. Generally speaking the vertical machine has smaller diameter wheels and is intended for smaller logs than the horizontal, though quite large logs can in fact be cut on it.

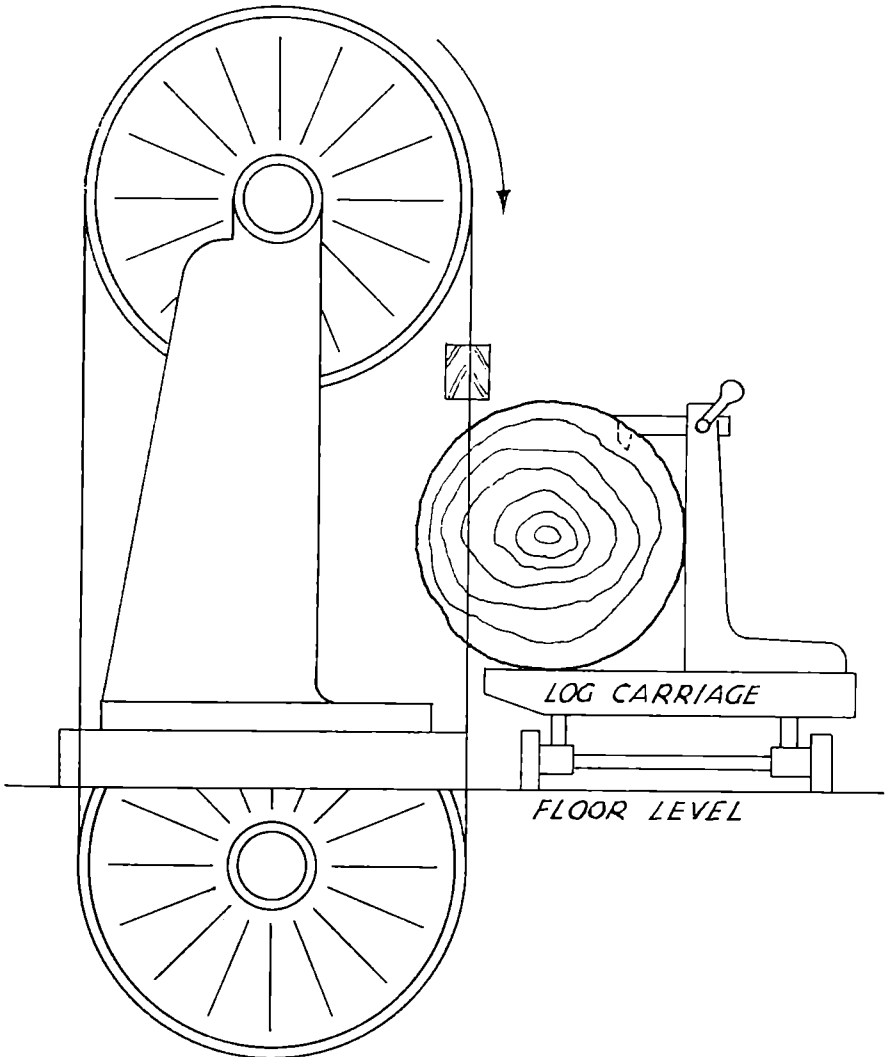

Fig. 58. Diagrammatic Sketch of Vertical Bandmill.

Reference should be made at this stage to the electrically controlled bandmill, excellent examples of which are now made by at least two well-known English machine manufacturers. The main principle in the design is that the sawyer, from a stationary position, controls the whole sawing and even the loading operation. Round logs are loaded on to the carriage by a hydraulically actuated log loader, dogged into position hydraulically, and if necessary turned over by the same means. The distance between the headblocks and the saw, and thus the thickness of the cut, is electrically controlled, and the feed of the carriage is infinitely variable through an electric hydraulic feed gear.

A comparison between these two machines has long been a subject for controversy in the trade. The horizontal has the advantage that heavy logs are adequately supported directly over the machine bed, which tends to give a more accurate cut. Further, the machine is entirely located on the floor surface, avoiding the necessity for an excavation. As the log overhangs the carriage in the vertical type, the cut slab or board tends to break off near the end of the cut and has to be supported. It is this very circumstance which helps to increase output as in this case it drops off whilst in the horizontal type it has to be laboriously lifted off. Both machines use the same type of saw blade varying from 4½ to 10 inches wide depending on the size of the machine. The maximum width is much higher in the larger mills of the U.S.A., Canada and tropical Africa, going up to 18 inches wide and in some cases being toothed on each edge.

A smaller version of the vertical bandmill is now gaining in popularity and is a distinct acquisition in English mills producing smaller size, coal mine timber, from small round logs and thinnings. Termed a "push band rack" it usually carries 48 inch wheels; the smaller log is carried on a short table mounted on easy running wheels and the table which is about waist high is propelled through the saw manually. It is a comparatively safe, easy and economical method of converting round timber which is too small to justify the use of a large bandmill, but in which the use of a circular rack bench would be grossly uneconomic.

Edging

The final operation in the conversion of round timber is the removal of the wane edge or edges from the through-and-through sawn stock to produce a plank, board or deal of parallel width. A machine in extensive use for this operation is the Straight Line Edger, illustrated in line by Fig. 59.

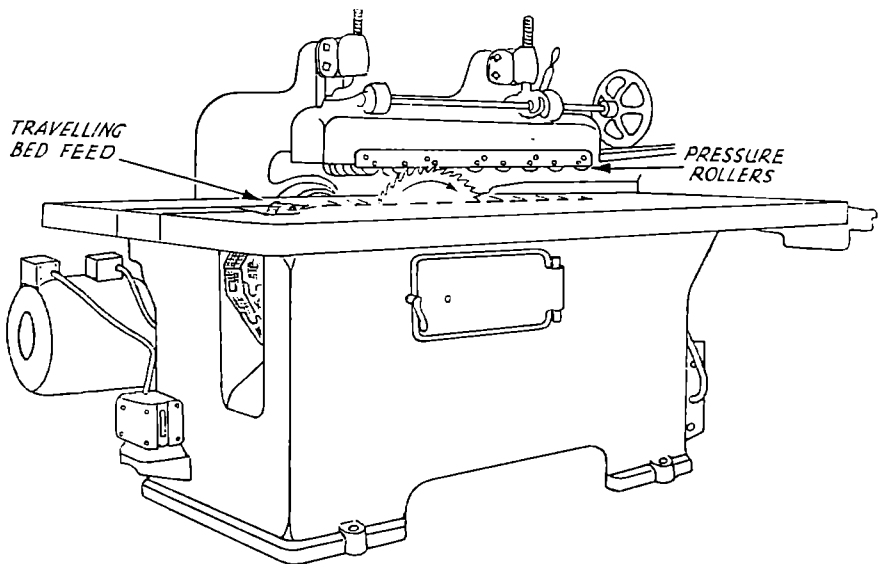

Fig. 59. Straight-Line Edger with Saw Mounted in the Table.

There are two distinct types of this machine; (a) in which the circular saw is mounted within the machine table as in Fig. 59, and (b) where the saw is suspended above the table and rotates to just tip a lead insertion within the feed belt running over the table surface.

The fundamental principle is the same in each case, the board is mechanically fed through the machine by being trapped between upper pressure rollers and a travelling metal belt or caterpillar track feed. By its very design this travelling belt or bed is caused to travel forward in a *perfectly straight line*, thus it must produce a perfectly straight cut. It differs from the more normal mechanically fed saw in that the cut is made without regard to the shape of the edge of the board. The roller feed sawing machine for instance feeds the timber forward with its edge in contact with the machine fence and the shape of the edge is faithfully reproduced in the cut; the edger always produces a straight cut off even a very irregularly, waney edged board.

The saw rotates at a much higher rim speed than the saw in the more orthodox machine, and the feed speeds are correspondingly higher.

A machine termed a "double edger" has a limited use in Britain but is quite popular in the softwood producing countries. Two circular saws are carried on a horizontal shaft, one in a fixed position the other capable of instantaneous adjustment along the shaft. The boards are passed through the machine by means of mechanically driven fluted rollers covering the width of the machine. The operator, with practised eye, assesses the parallel width which the board will make and sets his movable saw to this width from a quick reading scale; the stock is passed through at high speed and parallel boards are produced.

Saw-tooth Shapes and Methods of Setting

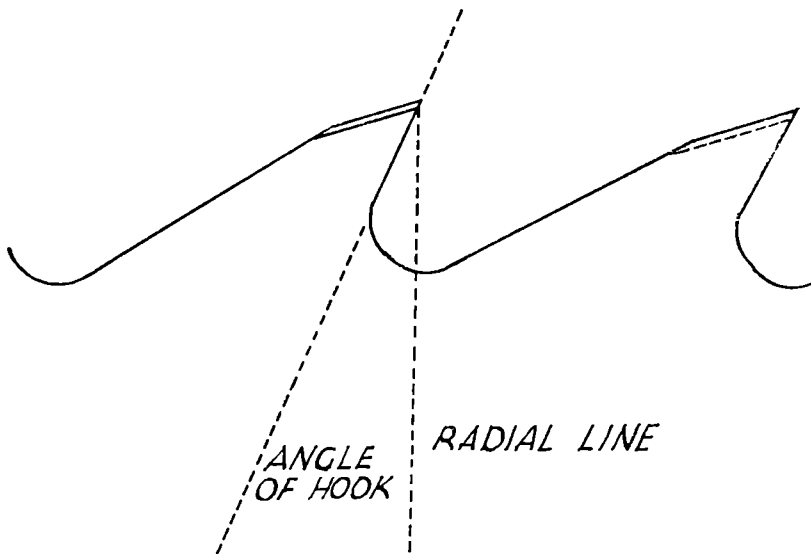

Fig. 60. Circular Saw Teeth for Ripping Soft Wood.

It is inevitable that there is a large divergence of opinion within the trade on the correct shape of saw teeth both for circular and bandsawing machines. The writer does not intend to dogmatise in the matter but to refer briefly to accepted principles for the shape of teeth for ripping and crosscutting.

Fig. 60 depicts a typical sawtooth for ripping softwood. The angle of hook, which is a very important factor, varies with the density of the timber from 15° for hardwoods (Fig. 61) to 30° for softwoods. The circular saw used for cross-cutting (Fig. 62) has what is termed negative hook or rake, i.e., the front of

the tooth comes *in front* of a radial line drawn from tip of tooth to centre of saw; the rip tooth with positive hook has the front of the tooth *behind* a similar radial line. This principle underlies the design of all saw teeth.

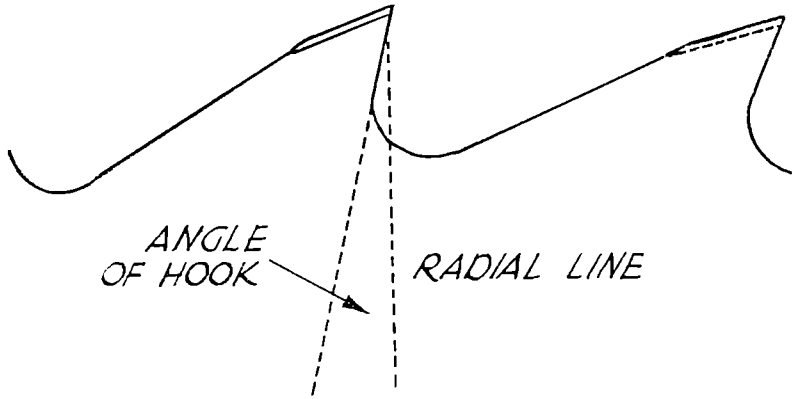

Fig. 61. Circular Saw Teeth for Ripping Hardwood.

Typical bandsaw teeth are shown in Fig. 63, the pitch of the teeth (the linear distance between tips of adjacent teeth) and the angle of hook are the two important factors. The actual outline of the tooth is usually of a regular curve to facilitate its sharpening on a mechanical saw sharpening machine. This machine invariably incorporates an abrasive wheel which follows the shape of the tooth by means of a cam mechanism, hence the need for a regular curve.

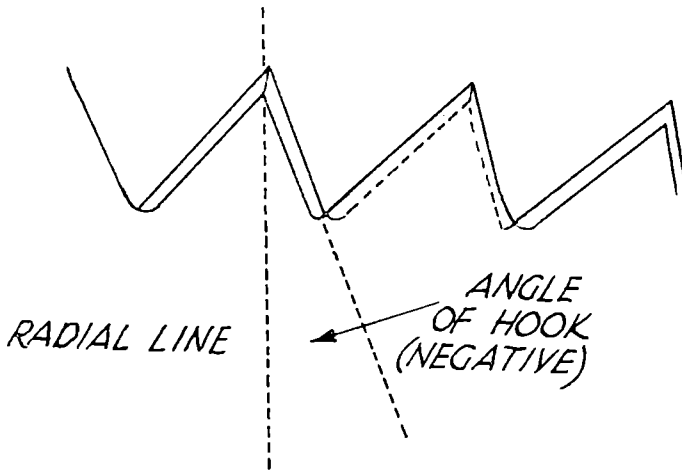

Fig. 62. Circular Saw Teeth for Cross Cutting.

In both circular and band saws some method must be adopted to ensure that the saw kerf or cut is slightly larger than the thickness of the body of the saw, to allow clearance of the blade whilst rotating in the cut and thus obviate friction and consequent overheating. The majority of circular saws are spring set as shown in Fig. 64 B, the teeth being bent over a predetermined amount corresponding to a set gauge; this amount varies between 0.010 in. and 0.020 in., depending on the size and gauge of the saw.



HARDWOOD



SOFTWOOD

Fig. 63. Typical Log Bandmill Teeth.

Wide bandsaws are swage-set as shown in Fig. 64 A; this is done mechanically by means of an instrument called a swager and the amount is equalised on each side of the saw by means of a side dresser. Swage-set saws tend to cut faster than spring-set saws because each tooth cuts away the full saw kerf, whilst the alternate method requires two adjacent teeth to cut the full kerf.

A.

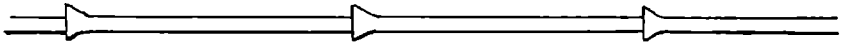

*SWAGE SET. USED MAINLY ON WIDE
BANDSAWS*

B.

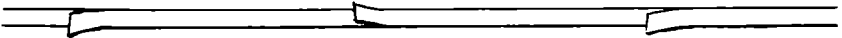

SPRING SET FOR ALL TYPES OF SAWS

Fig. 64. Methods of Setting Mechanical Saws.

In conclusion it should be clearly understood that this description of the conversion of round timber is necessarily sketchy and perhaps incomplete. It is only intended to convey a general idea of the work in a sawmill and purposely makes little reference to the very skilled work entailed, particularly in the maintenance of the various cutting agents.

FIRST AID IN AGRICULTURE

*Leaflet issued by the Minister of Agriculture, Fisheries and Food
and the Secretary of State for Scotland*

Minor Wounds and Scratches

Cover with a dressing (sterilized or adhesive) as soon as possible. Do not touch the part of a dressing which is to cover the wound. Waterproof adhesive dressings should be changed after each day's work.

When cleaning the skin round the wound avoid washing the actual wound because this can wash germs into it. A little bleeding helps to clean it.

If a minor wound or scratch is inflamed, or hurts, or festers, get medical attention.

Serious Injuries

Stop any serious bleeding at once, and send promptly for a doctor or an ambulance.

Control bleeding by direct pressure; apply a pad of sterilized dressing(s), bandage firmly to control bleeding, adding, if need be, another sterilized dressing and cotton wool; finally apply a triangular bandage. Where there is a head injury secure the sterilized dressing with two bandages crossing at right angles.

Secure any broken bones or injured joints with triangular bandages so that the injured part(s) cannot move. An injured leg may be tied to the unhurt one, and an injured arm bound to the body, padding between with cotton wool.

Make the injured person comfortable, protecting him from undue heat or cold.

Wounds caused by penetration by a fork or any other pointed object must be seen by a doctor the same day, because they may be serious.

SPECIAL INJURIES

Burns

Heat Burns and Scalds: Cover the burn with a sterilized dressing secured with a bandage and put nothing else on it. Do not remove clothing that is sticking to the burn and do not prick any blister.

Chemical Burns: Flush with plenty of water, remove all contaminated clothing and apply sterilized dressing(s) secured with a bandage.

Eye Injuries

Something in the Eye: Flush the open(ed) eye with clean water which may remove the object. If the object cannot be washed out, or if the eye appears to be injured or hurts after the object is out, put on one or more sterilized dressing(s), making a pad, and secure with a bandage to keep the eye shut and still; get the injured person to a doctor or hospital quickly.

Chemical in the Eye: Flush the open(ed) eye at once with clean water for at least fifteen minutes; then cover with one or more sterilized dressings making a pad and secure with a bandage. Take the injured person to a doctor or hospital quickly.

Bandaging: A medium-sized dressing may be best for a deep set eye, and a small one in other cases. This dressing is kept in place by the covering bandage running under the ear next to the injured eye and above the other. A second bandage round the forehead and back of the head helps to keep the first in place.

Electric Shock

Switch off the current if possible, otherwise pull the person free using an insulating material such as rubber or dry cloth; avoid touching the person's skin before the current is switched off.

If breathing has stopped apply artificial respiration and send for a doctor. Artificial respiration should be continued until breathing restarts. Nothing should be allowed to come before the need to restore breathing.

This leaflet is issued for the purposes of regulations made under Section 6 of the Agriculture (Safety, Health and Welfare Provisions) Act, 1956.

FIRST AID REGULATIONS

Explanatory Note by the Ministry of Agriculture

From 1st August, 1957 all employers of agricultural workers in Great Britain must provide First Aid equipment.

A First Aid box and, if necessary, additional containers, conspicuously marked "First Aid", containing specified First Aid requisites and an instructional First Aid leaflet issued by the Ministry, must be in a place easily accessible to his workers.

The equipment has been chosen on latest medical advice and the minimum requirements are set out overleaf; but there is nothing to stop an employer keeping additional items if he wishes. Some manufacturers are preparing ready-made kits which conform with the new regulations.

The official First Aid leaflet (copy above) is now available free of charge from the Ministry's local offices, the Ministry's Publications Branch, Soho Square, London, W.1, or The Department of Agriculture for Scotland, Broomhouse Drive, Edinburgh, 11.

Copies of the Agricultural (First Aid) Regulations 1957 (S.I. 1957 No. 940) are obtainable from H.M.S.O., or through any bookseller, price 3d. net (by post 5d.).

Advice on the regulations can be obtained from the Ministry's Safety and Wages Inspectors who will later check up that the legal requirements are being complied with, or from any of the Ministry's local offices.

What You Will Need

An agricultural unit with *one to three workers* will require a small *box* containing:

	<i>Quantity</i>
1. Sterilized wound dressings	
(a) finger dressings (containing either absorbent or boric acid lint) 	3
(b) small plain wound dressings	2
(c) medium plain wound dressings....	2
2. Triangular bandages of which the base shall not be less than 51 in. and each of the other two sides not less than 36 in.	2
3. Waterproof adhesive wound dressings of the following measurements:	
1½ in. by 2 in.	3
2 in. by 3 in.	3
4. Absorbent cotton wool, half-ounce packet	1
5. Official First Aid leaflet	1

For a unit with *four to ten workers* a larger number of items will be needed in the *box* as follows:

1. Sterilized wound dressings	
(a) finger dressings (containing either absorbent or boric acid lint) 	6
(b) small plain wound dressings	3
(c) medium plain wound dressings....	3
2. Triangular bandages of which the base shall not be less than 51 in. and each of the other two sides not less than 36 in.	3
3. Waterproof adhesive wound dressings of the following measurements:	
1½ in. × 2 in.	6
2 in. × 3 in.	6
4. Absorbent cotton wool, half-ounce packets	2
5. Official First Aid leaflet	1

For *every further 30 (or fraction of 30)* above the first 10, a *container* with the same contents as the larger box is needed. You do not have to provide more than three of these containers in addition to the initial box on any unit.

A contractor-employer must provide for his own men in the same way as other employers of agricultural labour, but where an employer lends a man to a neighbour without any financial transaction taking place, the borrowing employer has to provide for the man loaned to him. Further information on these points can be obtained from the Ministry's local offices.

SAFETY HINTS FOR CIRCULAR SAWS

Extract from: Safety Hints in the Use of Wood-working Machinery. H.M. Factory Inspectorate, Ministry of Labour and National Service. (H.M.S.O. 9d).

CIRCULAR SAWS

Circular saws are responsible for about half the accidents to users of wood-working machinery. The majority of these accidents are due to some failure of the "human element" and could be prevented by safer methods of working. The following safety precautions are suggested:

Saw Teeth.—The teeth of circular saws should be kept sharp; a dull saw is dangerous because it requires additional pressure on the wood and tends to tear the material instead of cutting it. A dull saw is much more likely to break than a sharp one, because of internal strains in the saw body due to unequal temperature effects.

Riving Knife.—Most of the fatal accidents which have occurred at circular saws have been due to the timber closing-in on the saw and being flung back towards the sawyer with great violence, or to timber coming in contact with the back teeth of a saw and being violently thrown off the table. The riving knife is the chief means of preventing this and it is, therefore, important that it should be properly used. If the riving knife is too far from the saw it will not adequately prevent the timber closing-in on the saw and, in addition, there is the risk of loose pieces of wood coming in contact with the up-running saw teeth. The distance between the back of the saw and the front edge of the knife should be kept as small as possible and in no case more than half an inch at the bench level, the maximum distance allowed by the Regulations. There is no reason why the riving knife, if securely attached, should be fixed farther than one-eighth of an inch from the saw at bench level. The bolts or studs for securing the riving knife should be properly tightened or the knife may be pulled against the revolving saw teeth and damage them or even break the saw.

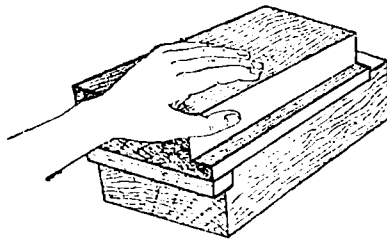

Fig. 65. Push-Block for Circular Saw. Note the guard strip to protect the thumb, and the cleat to engage the work.

Saw Guard.—An efficient type of saw guard is one in which the top part of the saw is covered by a guard of inverted "U" or "L" section, with a front extension piece which can be quickly and easily adjusted. Most accidents at circular saws occur at the front, and investigation has shown that many of them could have been prevented by proper adjustment of the guard, the front extension of which should be set so that the wood will just pass underneath it. In the event of the wood "kicking" or the operator slipping, the properly adjusted guard will prevent the hand coming in contact with the saw teeth. Adjustments of the guard should be made whilst the saw is at rest. (See Fig. 66.)

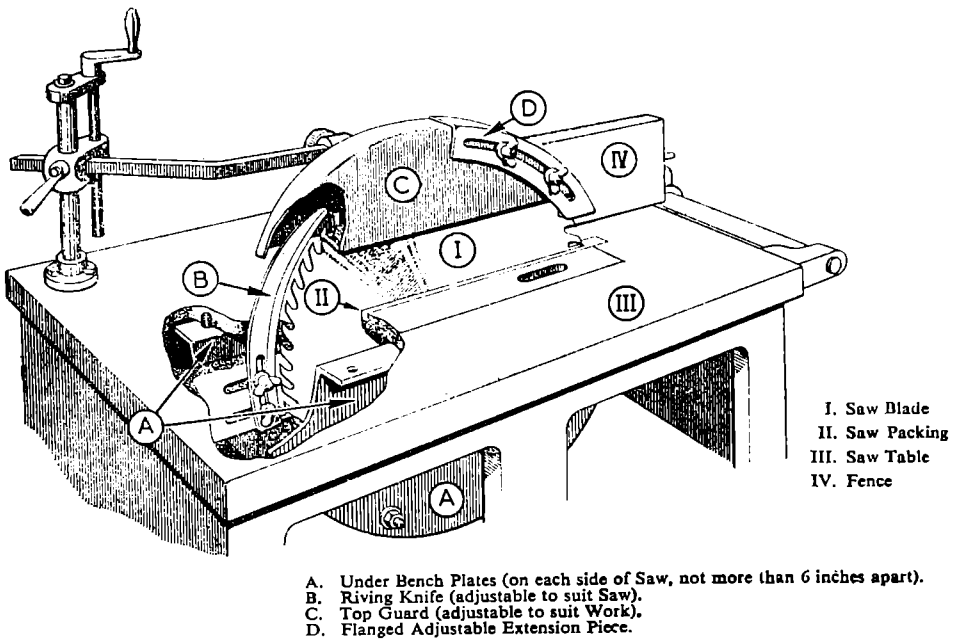

Fig. 66. Circular Saw Bench with Guard.

Push-Sticks, etc.—The use of push-sticks has saved many fingers and they should always be used whenever it would otherwise be necessary for the hand to approach very near the saw. Many accidents which occur when the last few inches of the cut are being made, would not happen if a push-stick were used. For certain types of work, such for example, as splitting a plank into a number of boards, the use of a suitable push-block is recommended. (See Fig. 65.)

Packing.—Accidents frequently occur during the “packing” of circular saws, or when the packing works loose while the saw is in motion and the operator attempts to push it back into place without stopping the saw. Whenever possible “packing” should be done whilst the saw is at rest. The saw-guard should be lowered as far as practicable over the top of the saw, as contact with the teeth of a stationary saw may cause serious injury. Many sawyers, however, prefer to adjust the packing whilst the saw is in motion and this can be done in comparative safety IF a proper type of prodder is used; for this purpose a foot rule or “any odd piece of wood” should NOT be used, since these are liable to break and bring the hand into contact with the saw teeth. A safe type of prodder which is often used consists of a bar about 16 in. long and $\frac{1}{2}$ in. diameter, bent to an angle of about 140° two inches from one end. The bent end is flattened out like a cold chisel (see Fig. 67). When a prodder of this type is used the risk of accidental contact with the saw teeth is considerably reduced if not entirely eliminated.

Saws not in use.—The saw should always be stopped when it is not actually in use, even when the operator leaves the bench for only a minute or so. The “other fellow” may slip and get hurt.

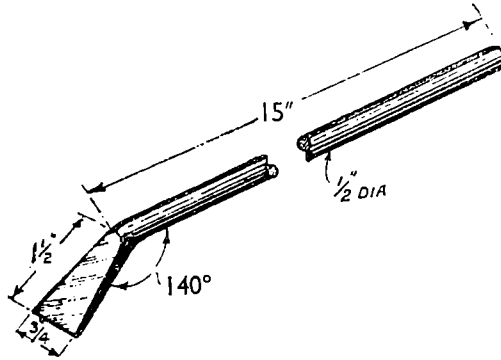

Fig. 67. Circular Saw Packing Tool—Mild Steel.

Loose Material on Saw Table.—Several accidents have been due to a thin strip of wood being caught up by the teeth at the back of a saw and projected forward with such violence that the end of the spear-like strip entered the sawyer's body, sometimes with fatal results. These accidents have not always been due to bad adjustment of the riving knife. Loose pieces of wood should not be left lying on the saw bench.

Removal of Gum or Resin from the Saw.—The only safe and effective method of removing gum or resin from the teeth and sides of a circular saw is TO STOP THE SAW and scrape off the gum with a suitable tool, such as a chisel or plane iron. Some sawyers occasionally check the formation of gum by pressing a piece of very hard wood against the face of the saw near the teeth whilst the saw is in motion. This is a dangerous practice as the least slip may mean a serious accident. Equally dangerous is the use of a mop made from a length of rope, such as is often used for applying oil to the saw, as shown by an accident to a man who was trying to remove gum by pressing against the saw a mop soaked with oil. In addition to the risk of slipping, the frayed end of the mop may be picked up by the saw teeth causing the worker's hand to be instantly drawn against the saw. Oil can be applied to a saw with comparative safety by pouring it from an oil can on to the packing.

Removal of Sawdust.—Removal of sawdust from beneath the bench should never be carried out whilst the saw is in motion; many accidents, some of them fatal, have resulted from this dangerous practice. It is important that cleaning out should not begin until the saw has stopped dead.

The risk of slipping will be greatly increased if chips, dirt, etc., are allowed to collect on the floor round the machines, and workers should, as far as possible, conduct their work so as to avoid this.

HOME-GROWN SOFTWOOD IN LONDON DOCKS A USEFUL SERVICE RECORD

By J. R. AARON

District Officer, Research Branch

There are many records covering centuries of fine service given by structures made from home-grown hardwoods. Sturdy oak beams and rafters have supported the roofs of our great cathedrals and other architectural treasures since

the fourteenth century. On the other hand authentic service records for structures in home-grown softwoods are much rarer: this is mainly because of the paucity of our coniferous flora—only Scots pine and yew were available to our ancestors in the middle ages for structural work, and the supply of long lengths of the latter would of course have been very limited. Because of this dearth of records for the use of native softwood for construction, it is particularly interesting to find one such record in the heart of London, only five minutes' walk from Tower Bridge.

On the Northern wall of Western Dock, which is one of a group known as London Docks, practically adjacent to Pennington Street in the postal district E.1, there is a series of five large warehouses which are known to have been built between 1803 and 1805, during the Napoleonic War. They are about 220 feet long and 90 feet wide and are four storeys high with spacious vaults. It will be recalled that in this period there was an effective blockade of our normal supplies of timber because much of Scandinavia was occupied by the enemy or his allies. Other sources of wood of suitable size and quality had to be found. According to the records of the former London Dock Company, now held by the Port of London Authority, timber for the erection of these buildings was obtained by a purveyor of the name of Robert Adams who is known to have operated in Gloucester, Somerset and South Wales.

All these warehouses are still in regular use today, and although some of the timber has had to be replaced on account of fire damage and because of local pockets of decay (mainly in wall plates and the ends of beams in contact with walls), the bulk of it is the original West of England softwood. It is still serving its purpose well more than one hundred and fifty years after erection and it seems likely to remain sound for many years to come. Among the structural members of each warehouse are beams 39 feet long with an $8\frac{1}{2} \times 10$ inches cross-section, queen posts 10 feet \times 6 inches \times 6 inches, and struts 6 feet \times 6 inches \times 6 inches. In the roof trusses of one of the warehouses there can still be seen the beams that supported a treadmill which was dismantled in 1912. (Plate 5, Central Inset.)

In addition to these four-storey warehouses there are two other warehouses in the London Docks which were erected during the same period, both of which are only single storey but nevertheless contain some interesting structural timbers. One of these, which is known as the Old Tobacco Warehouse, is adjacent to Tench Street at the North-East Corner of Wapping basin. It was also built between 1803 and 1805; in fact an oak column, which is one of a series 12 feet high with an 11 \times 11 inch cross-section, has been engraved by the carpenters with a few words commemorating the victory at Trafalgar. The roof trusses of this warehouse contain 10 \times 10 inch softwood beams, which are 54 feet long without any trace of a scarf joint.

The other warehouse which made wide use of home-grown softwood is known as the Skin Floor Warehouse, although it is now used for storing plywood and hardboard. It lies between Eastern Dock and Western Dock to the north of the Tobacco dock and it covers about two acres. It contains rather elaborate roof trusses borne on cast iron columns. The beams are 54 feet long, but have been generally made from two pieces of 8 \times 8 inch timber, joined together by a staggered scarf, above and below which steel plates have been bolted for added strength. The other timbers in use included 5 \times 2 $\frac{1}{2}$ inch rafters, 5 \times 7 inch struts and 5 \times 7 inch queen posts. It was erected in 1813.

It is understood that many of the piles on which the wharfs of London Docks were built were also made from native softwood; many of these too are still in use today, but they are below the water level and cannot readily be examined.

When the structures of all seven warehouses were examined in January 1958, the question arose, what species of softwood was used? In order to throw some light on this, borings from some of the timber structures were examined and it turned out to be a species of pine, almost certainly *Pinus sylvestris*. This is interesting, because even if it were grown on the most favourable sites available in South-West England, the trees would have to have reached an age of about 80 years to produce the 54 foot beams used in the Old Tobacco Warehouse. This implies that Scots pine must have been planted in that part of the country in the early 18th century or possibly even before.

The quality of the timber also calls for comment. No serious defects were seen. However, there were surface checks $\frac{5}{8}$ inch wide and a few yards long. Large cross-sections of softwood timber such as 8 × 10 inch almost invariably include the heart and this means that there is considerable tangential shrinkage at the surface, resulting in checks of this type. Knots were infrequent. No dead knots exceeding one inch in diameter, or live knots exceeding 2 inches in diameter, were found. Wane was completely absent. The number of rings per inch in the wood was well in excess of the eight annual rings per inch specified in British Standard No. 1186 (1952), "Quality of Timber and Workmanship in Joinery". This of course is to be expected when it is remembered that even our fastest grown softwoods generally settle down to such a rate of growth by the time they are fifty years old.

The timber was reasonably sound, although after many years of use decay had occurred at the ends of some of the beams where they are let into the walls and also in the wall plates. These had recently been repaired using ekki (*Lophira alata*), a highly durable West African hardwood. Beetle damage had not so far occurred, and it is perhaps possible that the regular coatings of whitewash, which is applied to the beams as well as the rest of the interior of the warehouse in order to comply with the Factory Acts, had acted as a deterrent to the furniture beetle; in some places the whitewash was nearly one-sixteenth of an inch thick. Another possible reason for the resistance of the timbers to attack by wood-destroying fungi and beetles, is that the specifications at the time of construction insisted that the timber be thoroughly "sapped". This implies that most of the less durable sapwood has been removed, and it certainly accounts for the complete absence of wane already referred to.

A service record of this kind is of particular value when one recalls the type of misleading criticism to which home-grown softwoods are subjected. For example not long ago a periodical asserted "Home-grown softwood is not as good as imported and never will be . . ." It is to be doubted whether imported softwood would have served any better than the West of England pine, which is still supporting some of the warehouses of the largest port in the world.

Acknowledgment

The Forestry Commission gratefully acknowledges the help given by the engineer's department of the Port of London Authority who have supplied most of the information on which this article is based.

DIVIDER AS A MEASURING DEVICE IN THE FIELD IN FORESTRY

By V. BLANKENBURGS

Clerk of Works, North-East England

The measuring divider (see Plate 21, Central Inset), also called measuring stick and measuring triangle, is old established and widely used equipment in Latvian and some other continental forests. As far as I know, this measuring device was introduced into British forestry only ten years ago in Kielder Forest. In spite of important advantages as compared with the conventional chain, the use of measuring dividers has not spread outside the Border area. This can be simply explained in that no publicity has been given to it in forestry literature at all and therefore very few people in the Forestry Commission have heard of it and even fewer have seen the device in use.

Therefore in this article I will attempt to give a fair picture of all the advantages and disadvantages of the measuring divider, based on some 25 years' practical experience using dividers and other measuring devices in various forestry survey work.

The measuring divider is used in the same way as one measures distances on a map with small dividers or compasses, only the legs of the divider are longer. In the Border Forest two sizes of divider have been used. In silvi-cultural work, where measurement is usually taken in chains, a divider having a distance of 0.1 chains, i.e. 10 dividers to a chain, is used. But in Engineering work a two-yard divider is favoured.

To compare with a 66 foot chain—orthodox Forestry Commission equipment at present—the divider has these (1) advantages and (2) disadvantages.

(1) Advantages

- (a) One man only is needed, instead of the two required when using chain or tape.
- (b) The measuring speed (miles per hour) is much higher.
- (c) The divider (at 2½ lb. to 3 lb.) weighs only about half as much as a chain or 200 ft. steel tape (including arrows) and can be folded to use as a walking stick when not being used for measurement.
- (d) It can be brought more quickly into use and back again for transport. Only 10 to 15 seconds are needed instead of 1 to 2 minutes when a chain or tape is used.
- (e) Properly painted or varnished the divider does not need any maintenance after use on wet ground or in wet weather. After using a chain or steel tape in such conditions the equipment must be dried, cleaned and oiled, an operation taking some 5 to 15 minutes.
- (f) Unless accidentally broken, dividers can be used for years but chains, through wear and corrosion of the links, especially if not carefully maintained, will stretch quickly, thus losing accuracy.
- (g) In taking readings gross errors occur less often using dividers than using a chain or tape.

(2) Disadvantages

- (a) The accuracy of a divider is less than that of an *accurate* chain.
- (b) It is difficult, if not impossible to use the divider on lines covered with obstacles, felled trees, deep drains, streams and rocks. It is also more

difficult to measure (less than 3 yards wide) lines through thick forest. If measurement should be possible in such conditions the accuracy and speed of the divider will always be less than on hard and even ground.

- (c) To obtain the highest possible speed and accuracy in work with a divider, some experience is needed.
- (d) The divider cannot, at the time of writing, be bought in this country, and to build it at home, some knowledge, as well as wood and metal working tools are required. Plans are of course needed for making it, but I can supply these, if required.

Conclusions

My own conclusions, after an exhaustive test are:

- (i) The accuracy of a measuring divider as a measuring device in field work is sufficient in most cases in practical forestry, compartment surveying and other mapping included.
- (ii) The actual measuring speed with a divider is approximately twice that with a chain or tape, but, because one man only is needed, two-thirds to three-quarters of the working hours spent in actual measurement can be saved by using the divider instead of chain or tape.
- (iii) In my view, it would be in Forestry Commission interest to introduce the divider in appropriate work in forestry as quickly and as widely as possible. To achieve this, the Commission should supply the local administration—foresters, foremen, gangers, Clerks of Works and Surveyors, when requested, with a measuring divider of approved construction.

ECONOMICS IN FORESTRY

by A. J. GRAYSON

District Officer, Research Branch

My aim in this article is to try to show very briefly what application the science of economics has to forestry.

What is the nature of economics?

To follow one famous economist's definition of the extent of the subject and say that 'economics is what economists *do*' does not lead us very far, even though it may indicate the difficulty of description. In the first place let it be quite clear that economics is concerned with human welfare, to the extent that welfare can be brought into relation with the measuring rod of money. Thus an economic approach to forestry is concerned with the way trees and forests may be manipulated to satisfy human desires: we are not primarily concerned with the trees' well-being except in so far as their condition affects the degree to which those desires are satisfied. Secondly economics is a science, studying facts and seeking to arrange them in such ways as allow logical conclusions to be drawn from them. There is, it is true, the view that if you give a set of facts to six economists you will certainly get six different interpretations—if not 7!

But the science has certain peculiarities of which the most striking may be that one can never run controlled experiments—people, unlike most inanimate objects, have an awkward capacity for remembering—while the subject is inherently complex because hardly one event of economic importance or significance fails to have repercussions on other aspects of economic life. (In this

respect an analogy may be drawn with meteorology). A succinct, though rather limited description may be helpful: 'economics is the science of the administration of scarce means, having alternative uses, for the satisfaction of human desires' (Benham). Many economists would not agree however that Benham's definition covers the most central question of economics. They might argue that technical progress, full employment and income distribution questions are more important, and because of the degree of State intervention which the policies to meet these objectives necessitate, the result may worsen the allocation of resources—the price mechanism does this job best if left to itself. It is as well to remember, indeed, that 'economics does not furnish a body of settled conclusions immediately applicable to policy' (Keynes).

What can economics achieve?

It is universally agreed that the policies that arose out of Keynes' treatment of the economy as a whole have meant throughout the world a very considerable reduction in the menace to economic health represented by business cycles (booms and their attendant slumps) which characterized the lives of industrial nations up to pre-War times. In war particularly, and in peacetime too, Government intervention in the economic activities of individuals and firms has grown markedly (taxation, subsidies, employment policy, trade agreements, and so on). Or again, economics has been applied widely in the management of firms, market research is now undertaken on a large scale, we have appraisals of production possibilities (based on technological research work study and cost accountancy), and also wage and price policies, investment plans, etc., all of which represent, in part at least, the application of economic thinking to everyday problems of life and business management.

The Need for Forest Economics

Where however in the practice of forestry do we perceive the working out of policies based on economics? Economics is, like politics, very much the art of the possible. An industry, a country, or any lesser or greater community we care to envisage, possesses a limited quantity of human and material resources which may be directed to various ends. Economics, working within the compass of technological possibility, politics and the social framework, can indicate the choices open to the community which are likely to achieve certain ends. In the light of the newly stated objectives of the Commission, of which the first two are: (a) to achieve an orderly expansion of timber production by extending the area of forest at a steady rate through new planting and by managing all Forestry Commission forests in accordance with the principles of sustained yield and (b) to manage the estate as a commercial enterprise and, within the limits set by the other policy objectives, to earn the highest possible return on the capital invested, we may turn to the questions which economics asks of foresters. Given our objectives, how are we to meet them in a way which yields greatest benefit to the Nation? Firstly we have to assess the resources which are available for us to use, and to consider in what ways they may be deployed. Secondly we have to see what products (both goods and services) are demanded of us. And thirdly we have to present in our synthesis plans which most closely match the objects laid down, while making the most economic use of our factors of production.

Economic Peculiarities of Forestry

I think it is worthwhile before proceeding further to consider the features of forestry which serve to distinguish it so clearly from other fields of human enterprise. (a) Forestry is a long-term undertaking. So long, in fact, that

Marx (*Das Kapital*. Book II. Chapter 13) held that it made forestry an industry of little attraction to private and therefore capitalist enterprise! This view would still obtain if owners were mainly concerned with the maximisation of short-term profits. What does the length of the production period really imply? Most important is the fact that forest investment involves a committal of factors of production over a long term of years in a way which cannot easily be varied. (Keynes' dictum that 'in the long-run we are all dead' has special significance for foresters.) Not only may the products of investment be demanded with quite different emphases at the end of the production period (*vide* the case of the oak woods established for the provision of ship-building timber), but also the form that the investment takes, e.g. its geographical location, management regime and silvicultural system, may mean that the costs of production turn out to be rather different from those initially foreseen. Differential evolution in the rewards paid to factors (wages in the case of labour, rent in that of land, capital cost and fuel in that of machinery, and so on) and technological innovations such as new thinning grades, regeneration methods, application of genetics and protection research, are likely to be potent influences affecting costs. Allied to the long production process are the circumstances of a high ratio of fixed capital in the form of growing-stock to annual turnover, and the wide scattering of inputs and returns through time.

(b) Second, there is the curious physical arrangement found in forests whereby capital and product are indistinguishable, so that in consequence the yield from close stands may take the form of removal of the very individuals which, together with their neighbours, constitute the capital on which new growth is laid. This feature is quite unparalleled in other enterprises, and forms the basis of the accepted policy of conservation through the adoption and application of sustained yield management, since the total available supply of wood cannot be harvested without destroying the forest's ability to produce wood for a certain period in the future.

(c) Third—and here forestry is similar to the fishing industry and agriculture—the asset may, with only a small amount of human intervention, be self-reproducing.

(d) Fourth, in its use of land, forestry may offer the *only* technically feasible productive use of this resource. (Whether forestry is economically practicable on marginal land or not is another matter.)

(e) Fifth, beside wood production many direct and indirect benefits may flow from the forest, e.g. provision of grazing, shelter and amenity, watershed protection, recreation. It is surely the social content of these benefits which cause forests more than any other natural resources to excite the interest of the conservationist with his concern for methods of assessing these 'imponderable' benefits, both now and in the future, which place high values on the perpetual provision of these services. Thus one of the most obvious ways of ensuring this high valuation is to employ low rates of discount in comparing present and future worth; for example, an asset reckoned to be worth £100 in 50 years is equivalent to only £9 at the present time if we discount at 5 per cent, but £37 if we discount at 2 per cent. Economic arguments of some subtlety—and dubiety—are involved in the justification for such treatment, which in part stems from the view that the benefits are either irreplaceable or priceless or both. While it is true that the valuation of these imponderable benefits may be impossible, it remains a fact that we can usually (as, for example, in the case of the provision of rural employment) make a good shot at assessing their cost.

The Approach to Forest Planning from the Side of Demand

In my view there is a great deal to be said for the approach to planning in

forestry which starts from the question: what products are required by the community? rather than from the opposed question of what, and how many, factors of production do we want to see employed in what way? Admittedly our instinct may be to deplore any forbearance with waste, whether of land, plants, growing stands or working skills and knowledge, and to work towards some sort of undefined 'silvicultural' ideal. But technical waste is not the same as economic waste, and on the strictest economic grounds the use of factors cannot be justified in a forestry enterprise unless the returns on investment are at least as great as those accruing from other investments which might be undertaken by the authority concerned. Clearly, economics cannot resolve questions primarily involving non-economic considerations (such as the aesthetics of afforesting barren moorland), but it can, as mentioned above, count the cost and point out the economic consequences of any policy which may be proposed. In general however economic welfare is served by meeting consumers' requirements and not to any important extent by making forest managers happy (much though this may seem desirable to them as a section of the community).

Let us very briefly see what the size of Great Britain's demand for wood and wood products has been in recent years. In terms of under bark equivalent the annual consumption of round, hewn and sawn timber has been running at about 700 million true cubic feet, of plywood and veneers about 50 million, and of pulp and paper derived from wood about 500 million. Imports, which account for such a very large proportion of our supply of wood and wood products, added up to a total value of more than £350 million in 1957 for all timber (round, hewn and sawn) plus manufactured wood articles plus pulp and paper, this sum representing about 8 per cent of our total import bill. Now the surprising thing about these figures is that we understand very little of the reasons just why these are the quantities consumed, how they depend upon such factors of economic importance as price, the availabilities and prices of substitute materials, the level of economic activity in the country, technical qualities, tradition, taste and so on. A great deal of what is called demand analysis, in the broadest sense, obviously requires to be done, and this work is of undoubted importance to the formulation of rational objects of management in our forests. The necessary studies proceed from the consumer's end and for purposes of forest management (i.e. in order to enable decisions as to treatment to be made) they must relate to tree types and sizes. It is true that we can be fairly sure that anything we produce can be used (given a positive approach to salesmanship) somewhere and somehow in our economy, but the question of vital concern is the price at which the goods can be sold. Obviously we want to ensure that by following soundly based yet flexible production policies we come out with the best reward possible for our efforts: if we do not our overseas competitors will beat us. In view of all the uncertainties, the manifold possibilities in the way of new invention, etc., the problem of forecasting is quite incapable of exact solution, but it is clear that any well-considered conclusions we may come to are better than none at all, and in this important field of research the developing tools of econometrics (statistics applied to the work of formulating economic models) will certainly be of great value.

The Supply Side

The reader who has come this far with me will no doubt be asking himself when we are going to get down to brass tacks and talk about the economics of forest management, silviculture, extraction and such matters. I want to emphasise however that it is most desirable—even obligatory if we are to act responsibly—in the first place to decide what we are aiming to grow, harvest and market. Of course it has to be recognised that the supply and demand

sides can never be kept wholly apart (just as one cannot say whether a mother or a father is more important in producing a baby) but it is my view that a more demand-centred approach is essential if we are not to lose sight of our main function.

Now, in very general terms, our final choice of growing technique will be amongst those courses which yield the greatest difference between sale price and cost of production. Some aspects of silvicultural technique and of exploitation require little economic expertise to show on the basis of work study results, cost accountancy and the like, the most rewarding method of organising and carrying out operations. On the cost side econometrics again can be expected to shed much light on the reasons for variations in direct operational costs, and the findings will be of immediate and practical importance to management. When we consider aspects of timber production involving future trends in costs and prices and the physical responses to treatments we are in deeper water. Costs of growing can be minimised by (a) reducing waste in the use of factors of production, e.g. making fuller use of the land resource by draining, etc., using trees and forms of stand of greater vigour and higher resistance to damaging influences, and a variety of other measures; and (b) reducing the waiting period, i.e. increasing the rate at which crops are capable of yielding produce (higher growth rate, heavier thinning). Let us for the moment ignore the repercussions that altered treatments are bound to have on the value of the wood produced, and consider at greater length what economic basis exists for certain technical practices. With the passage of time some ideas of what is a desirable specification for a particular operation have become quite settled and firm. For instance within a wide range of *physical* conditions we talk in terms of spacings of 5 or 5½ feet for Norway spruce, of D grade thinnings in larch, of 8 miles of road per square mile of forest and so on. It is often forgotten that *economic* conditions vary as widely as factors of the environment, and a desirable technical specification in one set of economic circumstances can be quite inappropriate in another. The resolution of the resulting difficulty involves a critical appraisal of technical *and* economic points jointly. In the wide variety of conditions encountered in this country it is hardly surprising that the optimal results for individual forests vary greatly, and in particular it seems that we need to revise our ideas on the ranges of rotation length to be adopted and of the roading intensity laid out.

Profitability and All That

One of the troubles that arise from the fact that items of expenditure and receipt are separated in time in forestry, is that it is difficult to decide on what basis we should assess the profit of any operation. To assess the return on capital (here used in the business sense of all outgoings on land, plants, labour, machinery and materials) we use the concept of financial yield. This is the rate of interest which, when used to discount items of expenditure incurred at definite times in the life of the crop, gives a total equal to the sum of the receipts discounted in like manner. Similarly, if any of the individual factors of production is accounted of special importance it is possible to gauge the return to that specific factor (e.g. land or labour). Whether one deals with the sum of factors (measured in money terms) or with separate factors (measured relative to the physical input as per acre of land, for example, or to the money spent on the factor) it is always the case that input of a factor or set of factors is separated in time from the return which results. This is as true of selection forest as it is of even-aged stands. Thus the indicator of net annual income per acre (equal to gross annual income minus expenditure per acre in the all-aged forest, or in the case of an even-aged stand, to the cash sum per acre of receipts through the

rotation minus total cash disbursements divided by the number of years in the rotation) is hardly a valid measure of the return to the land resource, since its computation takes no account of the inescapable fact that any regeneration or tending operation produces its return in the future and we must therefore make provision for the cost of waiting.

A stand may be defined as *financially mature* when the annual increase in the value of the growing stock plus any returns in the year (from thinnings, sporting rent, etc.) is no longer greater than the cost of retaining the stand. This cost is not wholly an actual moneycharge disbursed by the owner, but represents in addition the opportunity lost by not converting the growing stock into cash, investing it, and thereby earning simple interest on the capital sum. The appropriate rate of interest (the alternative rate of return) by which we judge, may be taken as the maximum which we can earn on the site in question, or it may be the rate obtainable in other forestry investment, or investment outside forestry. What will be the results of working to the principle of financial maturity? The rotation so determined will not be the *financial rotation* (i.e. that at which the financial yield culminates) unless the alternative rate exactly equals the financial yield of the crop in question. If the rate is lower, then the rotation should be extended to the point when financial yield equals the alternative rate. If the rate is set higher than the maximum financial yield of the crop then the rotation which loses least money (a) will be shorter than the financial rotation, and (b) should be reduced further as the gap between the two rates widens. It is impossible here to discuss the question of the figure at which the alternative rate should be set, the level chosen will depend on a variety of factors which will condition its relationship with the market rate of interest for long-term investments. In the case of state forests, the community may decide that a low rate should be adopted as a means to a particular end which the nation believes will serve society best. In practice if the thinning grade is a light one, and the alternative rate is put at a high figure, the most attractive rotation financially is often shorter than foresters profess to like. However unless sound arguments and well-justified fears of lowered future yield can be invoked, personal likes cannot be allowed to cut much ice—the issues at stake are too important. As a matter of fact so long as the prices for produce rise with size, heavier thinnings make *longer* rotations attractive. Another point is that a financially desirable rotation, especially if combined with a really heavy grade of thinning which implies a mean annual (volume) increment lower than that possible on the site, may be felt to be a 'waste' of the land. In spite of the fact that low prices characterize forest land in this country, the land resource is considered a precious asset of which the fullest possible use should be made. (It may be noted in passing that net annual income serves as some sort of indicator in this connection). But are we right to pay so much attention to one particular factor of production? It can be argued that a 'truer' (upward) valuation on land would be effective to some extent in making us more careful in its use, but apart from this why not have greater regard to our use of, for instance, labour, a factor which accounts for between one-third and a half of all cash disbursements in forestry work? In the absence of a proper pricing of the land resource it is difficult to come to any firm conclusion about the allocation of factors (in circumstances where market forces have free play the resulting prices of factors of production and their use in enterprises tend to levels where £1 spent on any one factor yields the same increase in the product) and we may well be forced to reply on value judgments in deciding when land is not being as fully exploited as is desirable.

Bearing in mind some of the qualifications made above, the essence of the profitability problem may be summed up thus: we are able in a free enterprise

economy to assess the value the community places on wood by observing the price arrived at in free exchange, and if we broadly accept the desirability of maximising our gains, we are left with the job of allocating our resources so that each component is as fully and productively employed as any other down to a level of marginal reward where we consider further application of resources is not justified by the ensuing increase in yield.

Conclusion

Such a brief review as the foregoing covering a subject which is as wide as forestry itself cannot help but sacrifice some precision in its statements of problems and methods which are in themselves so complex. The biological processes operating in the forest are complicated enough in all conscience, and the interweaving of economic variables involving the many uncertainties of human behaviour which we cannot avoid taking note of in management, should be accepted as a challenge by all of us in seeking to make the best possible use of the natural and man-made resources with which we work.

WORKING PLAN FOR TENTSMUIR FOREST, FIFE

By D. A. WOODBURN

District Officer, East Scotland

A Working Plan designed to adjust the age class distribution of the growing stock and to create a Normal Forest with a sustained annual yield was approved in 1955 for Tentsmuir Forest, one of the older forests in the East Conservancy of Scotland.

With all available ground planted and no prospect of subsequent acquisitions to complicate future plans, this forest was a suitable choice for planting for sustained yield within one forest, as opposed to grouping forests in the same neighbourhood to form a single felling series. The forest comprises a compact block, of 3,350 acres of pine plantations, planted on an undulating stretch of littoral sand. There is no fear of shifting sand dunes developing in this area, since open ground is rapidly colonised by grass. The elevation varies between 30 to 50 feet above sea level, and exposure is apparent only around the forest edge. Rainfall is about 20 inches per annum. The water table is several feet below the surface, fluctuating with the seasons, and competition for moisture is the principal factor affecting tree growth. The site therefore is markedly uniform.

Most of the planting was done in large annual plantings between 1922 and 1933, followed by smaller areas at irregular intervals until 1953. The areas and percentages of species planted are:

	<i>Scots pine</i>	<i>Corsican pine</i>	<i>Lodgepole pine</i>	<i>Norway spruce</i>	<i>Sitka spruce</i>	<i>Other species</i>	<i>Total</i>
Area Acres	2,323	861.5	33.5	60	68	15	3,350
Percentage	69%	25.5%	1%	2%	2%	.5%	100%

The age class distribution by 10 year age-classes, taking the position as at F.Y. 55, shows the abnormal age-class structure typical of state forests.

Age Class	1—10	11—20	21—30	31—40
Area Acres	440	510	1,540	860

Since Selection Forestry was ruled out by order, the choice of method was narrowed to the formation of an even-aged high forest, by conversion of the existing age-classes to a more normal distribution, by some form of clear felling. The rate of conversion is a matter of choice but it must be controlled by a specified rotation. With only some slight evidence from a small local stand of mature Scots pine as a guide the rotation was fixed at 80 years.

The Scots pine at Tentsmuir maintains Quality Class II growth up to 35 years, and Corsican pine Quality Class III. Based on the small mature stand of Scots pine, it was thought that growth of this species would fall off with age, whereas, judging by a row of old shelterstrip Corsican pine, this species would maintain its quality class to the end of the rotation. Accordingly a growth curve was drawn for Scots pine assuming the decline in growth from Quality Class II at 35 years to III at 75 years, and the corresponding main crop volumes for each age class read off the graph. Thinning increment is expected to be 50 hoppus feet per acre per annum between 20 and 80 years.

Using these yield figures for the whole forest and calculating as in the paper by Hummel and Grayson (1), a normal forest at Tentsmuir, on an 80 year rotation with seven 10 year age-classes of 420 acres and one 10 year age-class of 410 acres, would have a standing volume of 6,600,000 hoppus feet (average 1,970 hoppus feet per acre) and a corresponding increment of 275,000 hoppus feet per annum, i.e. 4.2 per cent of the growing stock. Delaying conversion until the present oldest age-class reaches rotation age would mean that the standing volume would increase to 10,500,000 hoppus feet with a corresponding increment of 273,000 hoppus feet per annum, i.e. 2.6 per cent of the growing stock. The disadvantages of delay in conversion have been fully described in Hummel and Grayson's paper.

The method of conversion originally planned, proved to be similar to Method V (Hummel and Grayson) i.e. 80 year rotation: Fellings to begin immediately at the rate of 420 acres in each 10 year period and they are distributed so as to leave the requisite number of acres (420) in each age-class to carry on to the end of the rotation. (One age-class will be fractionally different viz. 410 acres.)

The felling key, Fig. 68, illustrates the progression of fellings in the several age-classes and the distribution by age-classes at 10 year intervals, normality being reached after 40 years, the shortest conversion period possible, but entailing considerable fellings in immature stands. By this conversion method:—

The periodic annual increment would fall steadily from 350,000 hoppus feet at the start to 275,000 hoppus feet (the normal increment) after 40 years. The annual yield from fellings and thinnings would rise from 220,000 hoppus feet at 10 years to 275,000 hoppus feet at 40 years.

The standing volume would rise from 4,000,000 hoppus feet to the normal growing stock of 6,600,000 hoppus feet after 40 years.

The Technical Committee, before the plan was put into operation, approved a first decade's cutting of 200 acres only, but the main provision of the plan

remained unaltered, since it is possible that in the second and succeeding decades, cutting will be increased, the actual amounts being decided at each 10 year revision of the plan. This decision might entail a slower conversion regime but does not nullify the principal object of management of attaining a sustained yield. The other objects of management were to achieve the highest production of timber of species suited to the locality, by replanting with Scots and Corsican pines of good provenance, and to maintain, and if possible improve, the fertility of the soil by replanting a small proportion of broadleaved species.

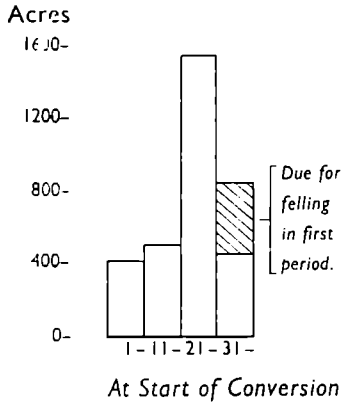

**TENTSMUIR FOREST
FELLING KEY**

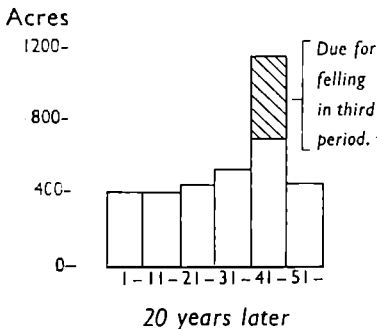
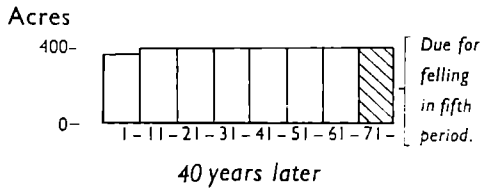
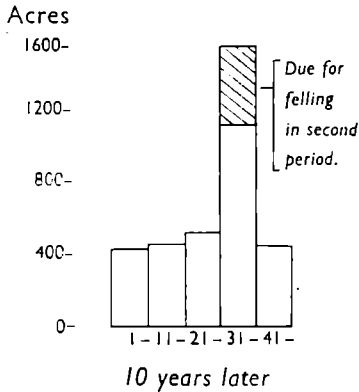
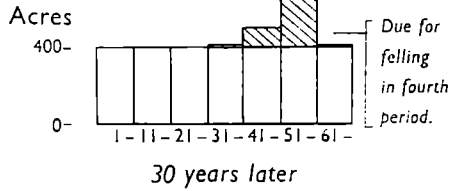

Age Classes and Areas of Felling

Period	Age Class	Area, acres
First ten years	31 - 40	420
Second	31 - 40	420
Third	41 - 50	420
Fourth ..	61 - 70	20
	51 - 60	280
	41 - 50	90
	31 - 40	20
Fifth ..	71 - 80	420

Fig. 68. Felling Plan for Tentsmuir Forest, Fife.

Although eight periodic blocks would eventually be constituted within the forest by the original plan, and possibly more by the amended conversion, only the first block needs to be designated for the present. Since the stocking and form of Scots pine at Tentsmuir varies widely in the oldest age-class, eight compartments containing the poorest stands of Scots pine were selected for the first decade's felling.

To reduce the possible dessication of the soil by sun and wind and to provide local shelter to the replanted crop, the annual coupe of 20 acres was sub-divided into 8 narrow felling strips, one in each Compartment, each the complete breadth of the Compartment, advancing annually from the north to south, the annual rate of advance being one-tenth of the length of each Compartment. The depth of the strips varies between 44 and 60 yards.

Although thinning yields were calculated for each decade, it is intended that the silvicultural needs of the stands should determine the degree of thinning. The yield predictions ought to be confirmed as soon as possible by increment measurements such as would be provided by the new management indicator plots. If the prescriptions of the plan were extended to indicate, even if only provisionally, those areas due for conversion in the second or third decade, a heavier thinning to stimulate girth increment could be carried out in such areas, to provide a larger size of timber at felling. In fact, heavy thinnings, begun with this object in those stands due for felling in the second half of the first decade, but abandoned when a dense mat of grass invaded the forest floor, showed that these must not be so heavy that crown development cannot keep pace with the sudden increase in growing space.

The plan prescribed annual felling in the autumn, followed by complete burning of lop and top, ploughing at 5 ft. intervals for reduction of weed competition and planting in the succeeding spring, and has now been in operation for three years.

Stump creosoting of fellings and thinnings was started in 1957, as for the East Conservancy in general, since *Fomes amosus* has killed small groups of trees in some older stands on the east side of the forest, where there has been some previous history of tillage.

The laborious, dangerous and costly work (£10 per acre) of burning the brushwood, was abandoned in favour of piling the brushwood in strips, which do not occupy much space, one plant row out of ten, and subside and decay rapidly; this costs considerably less (£2 10s. per acre). The present intention is to plant rows of hardwoods within the brushwood when it decays still further, to take advantage of the local protection and shelter.

Successful establishment of pines and rapid growth had been achieved in recent plantings in P.52 and 53, by shallow ploughing and planting in the furrow bottom, the success being attributed to freedom from grass root competition and the consequent greater availability of moisture for the trees. Ploughing in the stump-covered replanting sites presented more difficulty. In 1955 a twin-spring loaded disc plough was very successful, but put too much strain on the main frame of the tractor. Since then traditional mould board digging ploughs, the Cuthbertson tine and the Newlands, have been tried.

To minimise weevil damage, the Entomologist recommended the use of Didimac, a D.D.T. insecticide, in liquid form, 1 gallon to 4 gallons of water, the upper half of the tree being dipped in the solution down to the root collar before planting. So far the weevil population has not increased tremendously probably because the tree stumps dry out very quickly in this sandy locality. Sturdy 3-year pine transplants can survive weevil damage, but smaller 2-year transplants often succumb. The local experience is that the insecticide dip

delays flushing by several weeks, but research branch trials do not support this view.

The plan did not state specifically the proportion of Corsican and Scots pines to be replanted. The greater volume production would favour a higher proportion of the former, but Dr. Hummel, after inspection in 1955, thought that the absence of natural regeneration and the relatively thin crowns of this species, indicated the need for caution and its proportion should be kept to the present 25 per cent. The staff at present select Corsican pine for any slightly elevated dry ground and Scots pine for moister depressions.

Vermin are not a serious risk now. Disease virtually wiped out the rabbit in 1955 and roe deer have been reduced to a very low population.

There being no satisfactory Scots pine seed stands in the coastal zone of East Scotland as a suitable provenance source, the Geneticist selected a very vigorous stand within the forest, of moderately good form, and this stand will be thinned to promote crown development of selected trees within it as the future source of seed.

Control forms to regulate the cutting areas, to record yields and revenue, costs of felling and cultural operations, and replanting data, are maintained annually. This plan is not a complete working plan in the full sense, since some aspects of forest management such as protection, utilisation, marketing, communications, buildings, staff and labour have not been incorporated into the plan. These are largely covered by existing departmental arrangements, which have acted as substitutes for working plans in the past, but could be included later if thought desirable.

Reference

Hummel and Grayson (1957) The Achievement of sustained yield by varying thinning treatment and rotation. *Forestry*. Vol. XXX No. 2.

MEASUREMENT OF PERIODIC INCREMENT OF YOUNG CONIFER TREES

By J. L. G. HORNE
Divisional Officer, East Scotland

It is important that we make local increment studies. We are now establishing Management Indicator Stands, but it will be many years before we have enough of them to provide the information we require, and in any event it will be some years before we can measure increments on the areas we are now establishing. Apparently the Yield Tables are not applicable to many of our stands—those that are in a low Productivity Class, because of a slow start, but which are now growing quickly. Nor is it thought that the Tables will be easily applied to mixed conifer crops, though the trick of lumping a variety of mixtures into one species box is an ingenious expedient. Some simple and cheap method of assessing periodic annual increment would be a great boon to foresters.

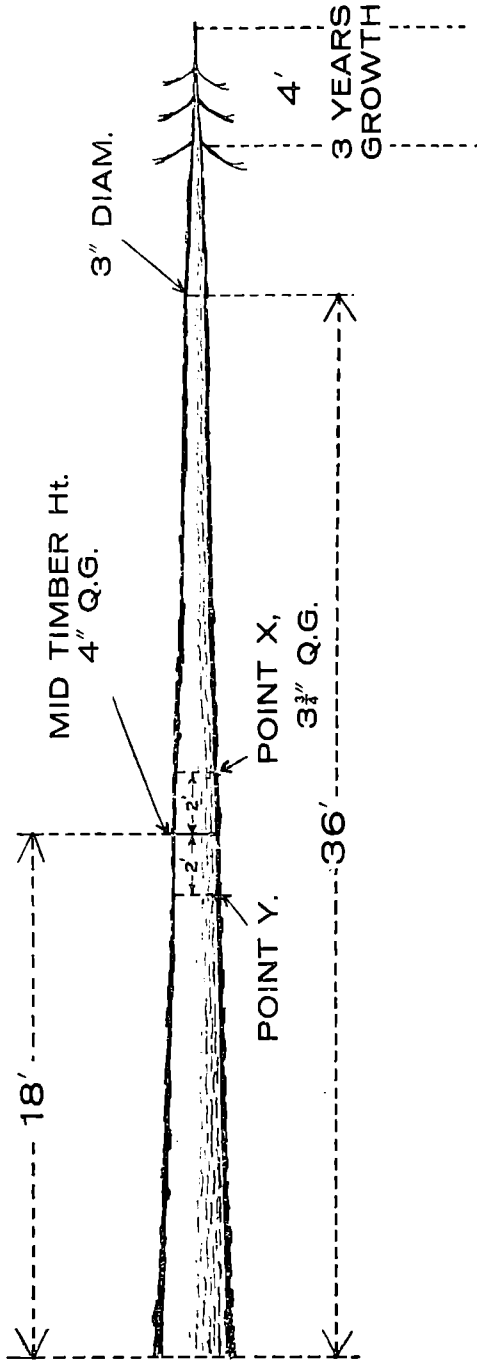

Fig. 69. Estimating the Periodic Increment of a Young Conifer.

The object of this preamble is to introduce such a method. The volume increment for a selected period of years of a young tree (i.e. a tree with a young top) can be found by four simple measurements:—

1. Height of the tree, to 3 inches diameter.
2. Quarter Girth at Mid-Height (to 3 inches diameter).
3. The height growth for the selected period of years.
4. The quarter girth of the tree at a point *half of the length* of the period's growth *above* the present mid-timber height (Point X in diagram). For example the tree illustrated in Figure 69 has the following measurements:

Measured Height to 3 inches diameter: 36 feet	}	Present	: 4 hoppus feet
Measured Mid Quarter Girth (at 18 feet up): 4 inches		Volume by hoppus tables.	
Measured Length of last 3 year's growth=		4 feet	
Estimated Height to 3 inches diameter, 3 years ago: 32 feet	}	Estimated	: 3.13 hoppus feet
Estimated Mid Quarter Girth at Point X: 3¾ inches		Volume 3 years ago by hoppus tables	
Therefore Estimated Increment for three years=		.87 hoppus feet	
		(=4—3.13)	
		or a percentage increment (on the original volume) of: 27.8%	

The assumption is that a tree is a cone, and in fact it is not; but at the part of a tree where the Quarter-Girth measurements are taken the tree is normally of regular taper.

Test of Results

The writer has not had the opportunity to cut up a sufficient number of trees to support fully the assertion, but on a limited number of trees the following measurements were taken:

- (a) Diameters at Point X, under bark.
- (b) Diameters at Point Y, *after a count back of 3 rings.*

Note: Point Y is *half of the length* of the selected period's growth *below* the present mid-timber height.

The mean of the measurements at (a) was found to be very nearly the same as the mean of the measurements at (b).

While no one will question the estimated *total height* of the tree in Figure 69 as it was three years ago. It is quite possible that the height *to 3 inches top* three years ago, was *not* 32 feet. For this reason it may be necessary to use *total heights* and *total volumes*. However we do measure many thinnings to 3 inches diameter, and how very convenient it would be if we could find their volume a number of years ago by two additional simple measurements.

The suggested practical application of this method is that a number of felled thinnings be measured (e.g. the sample trees in a tariff table measurement) and the current annual increment be expressed as a percentage of the total volume.

This percentage could then be applied to the standing volume which can easily be found.

BIBLIOGRAPHY ON WINDBLOW PREPARED IN JANUARY, 1958

By G. D. KITCHINGMAN

Librarian

- MACDONALD, J. 1928. Storm damage in Sample plots.
J. For. Comm. 7 (1928) 75-77.
(Observations on the damage done in the 77 effective sample plots (F.C.) in Scotland by the storm of 28th Jan. 1927. Storm worst in Tay valley and lower Deeside.)
- WATKINS, S. 1938. Storm damage.
J. For. Comm. London. 17 (1938) 137.
(A very short note saying that in pure spruce woods the roots interlock which leads to disaster in a windstorm. If the spruce is mixed with Scots pine the spruce may come to grief and the lone pine will be seen standing erect.)
- PETRIE, S. M. 1951. Gale warning: windblow in western spruce plantations.
J. For. Comm. 22. (1951) 81-90.
(A good article, discussing windblow and the spruce forests of the West Highland district.)
- EGGLETON, G. C. 1938. Damage to young plantations by wind.
J. For. Comm. London. 14 (1938) 117-18.
(Observations on the damage done, by a W.N.W. gale to Vaughan (Coed y Brenin) forest in Wales in May, 1937. Plantations affected were between 200 ft. and 1,000 ft. in elevation and aged 5-10 yrs.)
- ANDERSEN, K. F. 1954. Gales and gale damage to forests, with special reference to the effects of the storm of 31st January, 1953, in the north-east of Scotland.
Forestry 27 (2), 1954 (97-121 + 1 plate) 57 refs.
For. Abs. 16-579.
- STEVEN, H. M. 1953. Wind and the forest.
(Reprint from) *Weather*, London. 8 (1953) 169-74 + anemogram.
(An account of the storm of 31st January, 1953 and the damage done by it.)
- STEVEN, H. M. 1953. Storm damage to woodlands in Scotland on January 31st, 1953.
(Reprint from) *Nature*, London. 171. (1953) 454 (14.3.53).
- LINES, R. 1953. The Scottish gale damage.
Irish For. 10 (1), 1953 (3-15) 6 refs. 3 photos.
(Gives meteorological data, extent of damage, factors affecting the damage, and damage by species.)
- FEAVER, B. R. 1953. The Gale Damage of 31.1.53. A Preliminary Note.
Scot. For. 7 (2), 1953 (48-50).
General statement of damage and problems to be faced.
- LINES, R. 1952/53.54. Investigations into damage by the gale of January 31st, 1953.
Rep. For. Res. For. Comm. London. 1952/53, 1954 (47-9).
For. Abs. 16-1850.

- LAUGHTON, C. & HEDDON, V. 1927. *Great Storms*. Allan, London. 1927. 10/6.
- ANON. 1955. Letter from N. McGregor entitled Effects of the Great Gale. *Scot. For.* 9 (4), 1955 (181).
- STEWART, H. Sir 1913. Some lessons from recent gales. *Trans. R. Scot. Arb. Soc.*, 27 (1913) 172-4. (Mainly about marketing.)
- MACKAY, W. 1938. Wind Damage. *J. For. Comm.* London. 17 (1938) 152-3.
- ALLAN, T. 1935. Windthrow. *J. For. Comm.* London. 14 (1935) 130-1.
- DAY, W. R. The soil conditions which determine wind-throw in forests. *Forestry* 23 (2) 1950 (90-5) 3 refs. *For. Abs.* 12—3343.
- MUNGER, T.T. Windfall in relation to cutting. *For. Res. Notes. Pac. Northwest For. Range Exp. Sta. No. 34.* 1946 (11-12). (Observations on windthrow in relation to road clearings and clear cutting in dense stands of Douglas fir, spruce and hemlock.) *For. Abs.* 9—1246.
- HEINRICH FAUST, DR. Investigations into forestry damage with regard to the nature of the wind in a gust. *Meteorologische Rundschau* 1 (9/10), 1948 (290-297). Translation (17 pages of typescript) in F.C. Library. *For. Abs.* 12-675.
- CURTIS, J. D. 1943. Some observations on wind damage. *J. For.* 41 (1943) 877-82. *For. Abs.* 5, page 273.
- MACDONALD, J. M. 1952. Wind damage in middle-aged crops of Sitka spruce and its prevention. *Scot. For.*, 6/3/. 1952 (82-5). *For. Abs.* 14-391.
- ROBERTSON, D. 1952-54. Observations on windblow in young plantations. *J. For. Comm.* 23 (1952-4) 67-9. (Effect of the different grades of thinning on resistance to windblow.)
- ANON. 1943/50, & 53. Damage to Scots pine on exposed sites. *Rep. Minist. Lands, Eire, on Forestry 1943/50, 1953 (24).* *For. Abs.* 15—1461.
- ARNOLD-Forester, W. 1951. Wind shelter and wind tolerance. *J. R. Hort. Soc.* 76 (10) 1951 (341-7) 6 photos. (Notes on some wind tolerant shrubs and trees in the U.K.)
- ACKERS *Practical British Forestry.* p. 162-66. Deals excellently with Wind damage.

BIBLIOGRAPHY OF EFFECT OF SEA SPRAY ON TREES AND SEA-SIDE TREE PLANTING

By G. D. KITCHINGMAN

Librarian

- ANON. Chap. XII of Grigor's *Arboriculture* (2nd ed. 1881) is titled 'on sea-side planting' (see pages 93-116).
- BRETT, I.
1954. Observations on the damage caused by sea water to plantations in Norfolk and Suffolk.
Quart. J. For. 48 (1954) 217-8.
(Seawater flooding.)
For. Abs. 16-594.
- EDLIN, H. L.
1943. A salt storm on the south coast.
Quart. J. For. 37. 1943 (24-6).
For. Abs. vol. 4, page 245 (a good abstract).
- GILCHRIST, W.
1870. On the various kinds of trees and underwood best suited for planting within the influence of the sea-breeze on sea coasts or islands.
Trans. Scot. Arb. Soc., 5 (1870) 143-149.
- MICHIE, C. Y.
1870. On the various kinds of trees and underwood best suited for planting within the influence of the sea-breeze on sea coasts and islands.
Trans. Scot. Arb. Soc., 5 (1870) 150-154.
- EDLIN, H. L.
1957. Saltburn following a summer gale in south-east England.
Quart. J. For. 51 (1), 1957 (46-50).
On 29th July, 1956, a south-westerly gale of unusual violence swept Britain, and its effects on trees in the S.E. are here discussed.
For. Abs. 18-2965.
- ANON. *Archiv. f. Bot.* 11 No. 12. 1912.
See Lundegardh *Klima und Boden* p. 228 3rd ed.
- MITSCHERLICH, G.
1942. The influence of sea wind on the growth of pine, spruce, beech, birch and alder.
Thar. forstl. jb. 93 (1942) 345-73 ((G.g.))
For. Abs. 4, p. 186 (good).
- ROSTRUP, E.
1906. Saltvands Indvirkning paa Naaetraeer (Effect of sea water on conifers).
Tidsskrift. for Skovvaesen 18 (1906) 136-9 ((Dan.))
- ANDERLAND, Prof.
1912. Forest conditions in Abbazia district of Istria.
Allg. Forst. u. Jagdzeitung 88 (1912) 236-9.
The author observes that broadleaves suffer more from salt-spray than conifers, and particularly sessile and turkey oak. The elm appeared to be the most resistant.
- KASUYA, Y.
Damage to plants due to saline winds of typhoon in the southern part of Boso peninsular.
Misc. Inform. Tokyo. Univ. For. No. 10 (1955) 7-14.
((Jap.e.))
(Generally the evergreen broadleaved trees were more salt-tolerant than the deciduous. Some 32 timber species discussed.)
For. Abs. 16-4185.

- AMORY, C.
1956. Seaside plants defy the elements.
Plants and Gdns. 12 (4), 1956 (297-9).
(Lists species that have been grown successfully on an island off Cape Cod exposed to salt spray. Garden situated half a mile from shore Nr. Boston, Mass. Good evergreens: *Ilex opaca*, *Pinus thunbergi*, *Juniperus chinensis keteleeri*, Black Hills and Colorado spruces, pines. Neutral or negative position are: Tiger-tail, Serbian, dragon, oriental and Himalayan spruces, white, red and lace-bark pines and white firs. *Cryptomeria* is an enigma. One flourished on Cuttyhunk Island, which is almost devoid of trees.)
For. Abs. 18-4090.
- MOSS, A. E.
1940. Effect on trees of wind-driven salt water.
J. For. 38 (1940) 421-5.
For. Abs. 2, page 118.
(Investigations following the New England hurricane of 1938.)
- BEELER, M.
1957. Salt spray injury along the Jersey coast.
Shade Tree 30 (7), 1957 (2).
(Description of damage by a sea fog and salt-spray.)
For. Abs. 19-541.
- WYMAN, D.
1939. Saltwater injury of woody plants resulting from the hurricane of September 21, 1938.
Bull. Arnold Arbor., Ser. 4, 7, 1939 (45-52).
For. Abs. 2, page 118a.
(Observations on the effect of salt water damage in Massachusetts and Rhode Island.)
- WALLACE, R. H. &
MOSS, A. E.
1939. Salt spray damage from recent New England hurricane.
Proc. nat. Shade Tree Conf. 15, 1939 (112-9).
For. Abs. 2, page 191a.
- GAUT, A.
1907. *Seaside planting of trees and shrubs.*
Country Life, London, 1907. pps. 101.
(An interesting little book discussing the problems of growing shelter-belts on the coasts of Yorkshire.)
- BOODLE, L. A.
1920. The scorching of foliage by sea winds.
J. Min. Agric. 27 (1920) 479-86.
(Concludes that damage is mainly due to drying effect of wind. Many references to foreign work on the subject.)
- ADKIN, B. W.
1912. The Monterey Pine (*Pinus insignis*) in Britain.
Quart. J. For. 6 (1912) 13-20.
(Detailed description of the Monterey pine which the author considers the best tree to plant on the south-west coasts of England, Wales and Ireland.)
- JONES, B.
1948. Hurricane damage to pine and scale insects.
J. For. 46 (1948) 262.
P. mugo unaffected by salt spray.
For. Abs. 10-661.

- BUXTON, A.
1942. Norfolk sea floods. General effects of the February 1938 flood seen in 1942.
Trans. of the Norfolk and Norwich Naturalists' Soc., Norwich 15 (1942) 332-41.
For. Abs. 10-2535.
(This abstract gives a long list of trees in order of resistance to salt.)
- WEBSTER, A. D.
1918. *Seaside Planting*.
Fisher Unwin—London—1918. pps. 156.
(Chapters 4 and 5 of this book discuss trees and shrubs suitable for planting, in gardens generally, near the sea.)
- ANON.
1910. Forestry in Lancashire—(Report of Judges on plantations and home nurseries).
Quart. J. For. 4 (1910) 254-6.
(Winter winds come heavily laden with salt spray from the Irish sea. Special damage on Walney Island and Barrow peninsula. Mr. Albert Wilson in the *Met. mag.* for Jan. 1895 and in his *Flora of West Lancashire* discusses deposits made by the gale of Dec. 22nd, 1894 seven miles from the sea.)
- ANON.
1940. *The Imperial Forestry Institute, University of Oxford. Sixteenth annual report, 1939-40.*
Imperial Forestry Institute, Oxford. 1940 p. 11.
For. Abs. 3, page 71 (a).
(European larch, sycamore, ash, beech and oak are all susceptible to leaf scorch if sprayed with sea-water.)
- BARTHOLOMEW, C. R.
1955. Effect of an agricultural spray on forest trees.
Quart. J. For. vol. 49 (2), 1955 (139-40+1 photo).
For. Abs. 16-4186.
- EDITORIAL
1764. Trees and shrubs which will thrive near the sea.
Museum Rusticum et Commerciale 1 (1764) 16-17.
(Mulberry trees doing well—Scots pine being killed by small 'animalcula' that nestle in the buds.)
- COWAN, B.
1886. Trees and shrubs suitable for the seaside and when Alkali and other gases are present.
Trans. Eng. Arb. Soc., 1 (3), 1886 (15-22).
- MAJOR, J.
1847. Seaside planting (near Scarborough).
Gard. Chron. 7 (1847) 716-7 & 766.
- HEPBURN, I.
1943. A study of the vegetation of sea cliffs in North Cornwall.
J. Ecol. 31 (1943) 30-39.
- RUTGER, T.
1833. The evergreen oak compared with the cluster pine, as a nurse for plantations on the sea coasts.
Gard. Mag. vol. 9 (1833) pp. 543-7.
- HUTCHISON, R.
1880. Trees best adopted for planting as shelter in the Islands of Scotland.
J. For. Est. Man. 4 (1880) 261-4.
(Reprinted from *Trans. Scot. Arb. Soc.* vol. 9, pages 140-4.)
- HUTCHISON, R.
1881. On the varieties of trees best adapted for planting as shelter in the Islands of Scotland.
Trans. Scot. Arb. Soc., 9 (1881) 140-4.

- GRIGOR, J.
1849. On planting within the influence of the sea, or on exposed barren tracts.
Trans. Highl. agric. Soc. Scot. Ser. III, Vol. 3 (1849) pp. 183-92.
- BROWN, G. E.
1879. Seaside plantations (in County Down).
J. For. Est. Man. 3 (1879) 165-8.
(Notes on how various trees have fared.)
- SCOTT, D. S.
1880. Planting for shelter on the sea coast (on the west coast of Ireland).
J. For. Est. Man. 4 (1880) 250-1.
(Farmers' screens were composed of poplar, willow, alder, elder, etc.)
- RUTGER, T.
1834. Raising plantations near the sea.
Gard. Mag. vol. 10, (1834) pp. 495-9.
(Experience in Dorset and Cornwall.)
- ANON.
1861. Seaside planting.
Gard. Chron. (1861) 1026. 1116 and 1136.
- EDITORIAL
1899. Sea-side planting.
Gard. Chron. 25 (1899) 369.
(Contains useful experiences on successes and failures.)
- BAYNE, L.
1876. Planting in exposed and maritime situations.
Trans. Highl. agric. Soc. Scot. Ser. IV, Vol. 8 (1876) pp. 66-79.
(In North Wales.)
- HEPBURN, I.
1952. *Flowers of the Coast.*
Collins, London. 1952 (New Naturalists Series).
- EDITORIAL
1858. Trees and shrubs for situations exposed to the sea.
Gard. Chron. 1858 716, 720 and 796.
- CRAYON
1853. The evergreen oak as a sea-side plant.
Gard. Chron. 13 (1853) 260.
(Observations on trees doing very well by the sea-side in Guernsey.)
- WEBSTER, A. D.
1918. *Seaside planting.*
Fisher Unwin—London—1918.
- KIDSON, C.
1957. Problems of Coastal Conservation.
Chartered Surveyor 89 (1), 1957 (369-373).
- CLARKE, W. B.
1833. A notice of the effects of wind on trees growing on the coast near Poole, Dorset.
Gard. Mag. vol. 9 (1833) pp. 547-9.
- HILLIER, E. L.
1943. Notes on the future of conifers with hardwoods in the British landscape.
1943 p.p. 8.
For. Abs. 7—19.
(Suitable species for maritime districts are suggested.)

TELLING THE FORESTRY STORY

By DENNIS HEALEY

Information Officer

When I joined the Forestry Commission the veil that had concealed our activities had been partially raised by Mr. Wynne Jones who, in a comparatively short time before leaving for the New Forest as Deputy Surveyor, made a most efficient and strenuous effort to awaken public interest in forestry. His must have been an arduous task, for his work was done towards the close of an era in which the Commission had perhaps tended to shun the spotlight of publicity, no doubt understandably through unfamiliarity. Some very early files make interesting reading for they reveal, for example, that in 1924 the Commission had Treasury authority to spend money on exhibits at agricultural shows, but only up to a sum not exceeding £100 in a year; and that the space allotted to the Forestry Commission for the Royal Show, 1932, was 45 feet by 3 feet—compared, for example, with the 70,000 square feet or more which we occupied at this show in 1958!

Certainly times have changed, but before referring in some detail to the scope of the Commission's current publicity work some reference to the history and aims of the Government Information Services might well be made.

Need for an Informed Public

The Government has, in fact, maintained Information Services in one form or another since before the first world war. Their size has varied with circumstances but their purpose remains the same—to meet a need on the part of the public for information and explanation about government, coinciding with an increased need by government itself for the intelligent co-operation of the public in the administration of public services. Probably the first deliberate use of an information service was in 1912, after the passing of the National Insurance Act, when Mr. Lloyd George organised a team of lecturers to tour the length and breadth of Britain and explain the new legislation to employers and employees. Since then there has been an almost continuous flow of legislation affecting the population and as the public need for official information has grown, so have the means of making it available. Newspapers and periodicals have expanded steadily, matched by the growing influence of the film and radio and, latterly, television, all excellent media for the purposes of dissemination.

In the 1914-18 war, the Department of Enemy Propaganda was the leading exponent and protagonist of Britain's cause, while the War Propaganda Bureau and the Press offices of the various Ministries all played an important part in presenting the British case in Allied and neutral countries. Then, in 1917, a War Aims Committee carried out propaganda at home, and in the last year of the war a Ministry of Information was formed under Lord Beaverbrook. After the war some of the functions of the Ministry of Information, which was to be disbanded, were transferred to other Departments. The Air Ministry had a Press officer from its inception in 1919 and a Housing Information Department was set up by the Ministry of Health at about the same time. The well remembered Empire Marketing Board came into being in 1926 and remained until 1933, spending part of its £1 million a year on publicity films, posters and exhibitions. By 1937 there were Public Relations Divisions in almost all the Social Service Departments and at 10, Downing Street. In 1939, on the outbreak of the second world war, a Ministry of Information was again set up, primarily for the issue of war news and comment and for censorship purposes; not long after the end of hostilities the Ministry was abolished and there was

established the present Central Office of Information, with its important responsibilities for helping in the dissemination of information at home and securing publicity for Britain abroad, and with its virile Regional organisation which has on many occasions helped the Commission develop its associations with the provincial Press.

Promoting a Forest Sense

So much, then, for the background of public relations against which the Commission's Information Service was introduced little more than a decade ago. This, as in some other Departments, is subject to restrictions through limitations in staff and money, but we hope it may be claimed that some useful progress towards establishing a public forest sense has been made—a virtue that was certainly almost, if not completely, lacking when our entry into the field of public relations took place. Publicity (or information or public relations, the terms are synonymous) is a nebulous undertaking and without embarking on an expensive social survey it is difficult to assess just how much more aware the public has become in recent years of the benefits that forestry can bring to the nation. We can only judge this by the increasing number of unsolicited requests that are being received from educational and other organisations for information about forestry and for visual teaching aids on the subject, from the number of approaches for information from a wide variety of public and voluntary organisations, and perhaps from the degree of authenticity which marks the public utterances and writings of persons not normally connected with forestry, but nevertheless having occasion to discourse on countryside affairs. All these must surely add up to what is no more or less than the snowball effect of our information work at Headquarters and as practised by our Officers in one way or another in the field. Certainly if one recalls the position in Wales of a few years ago and compares it with that now prevailing, there is cause for some gratification, though by no means complacency. Not so long past it was manifestly a case of "No more forestry for Wales at any price", where public opinion was concerned. Now the attitude has changed to one whereby the Welshman might well be quoted as saying "We know we must have forestry because it is good for our economy. But get the other man's land planted first if you can!" Not entirely satisfactory, of course, but significant, to say the least.

Then there is the all-important matter of fire protection. No amount of publicity will entirely eradicate fire risk since the biggest percentage of fires is caused by sparks from railway engines and, presumably, the day is still some distance ahead when steam will have given way completely to the electric train or diesel-electric locomotive. But fires caused by public agencies can undoubtedly be reduced in number by properly applied campaigning, and statistics point to an encouraging measure of success; I am informed that since the Information Section commenced its operations the number of fires from causes over which we ought to have some control has declined, in relation to the acreage at risk, by 40 per cent. The causes in question are the general public or unknown causes, which may also imply human agency and may include the courting couple who seek the solace of the woods as well as that of their own companionship and, though resisting (we hope) all other temptations nevertheless succumb to the cigarette.

Two other contentious subjects remain with us—the general question of amenity, linked as it is with the planting of conifers in great quantity and reduction in the amount of hardwoods being grown; and the ill-informed charge that, darkly, the Commission plots to acquire all the best land to the detriment of agriculture. Our publicity has always taken account of these problems and it is fair to say that the complaints have lost some of their virulence.

The Forests Speak For Themselves

The staff engaged on forestry publicity is small and the amount of money available is likewise, in relation to the £18 million to be spent on the Government Information Services in the current year, with about £3,250,000 of this going to the Home Information Services. But despite restrictions, the cause of forestry must be furthered and publicity may, indeed, be more important than ever now that timber for defence purposes no longer ranks as the major reason for the justification of large scale forestry. Certainly the remaining issues—the economic and social values of the industry—are sufficiently important to warrant their being brought home to the public to the greatest possible extent.

Fortunately many of our forests are now speaking more and more for themselves and few indeed are one's acquaintances who, in these days of increased and extensive travel, have not encountered visual evidence of the Commission's work. It is these people in particular whom one finds quite amazingly anxious for further enlightenment about the Commission's operations and this, together with the education of the less knowledgeable, can effectively be achieved with the aid of the Press. It is for this reason that field officers have been asked to help by inviting parties of Press representatives to look over the forests. There is indeed much to see and those economic and social features which can be emphasised during visits need hardly be elaborated upon here. Rather, perhaps, might one take the opportunity to give a few hints for the benefit of escorting officers who may be entering the sphere of publicity for the first time—our officers with longer service are already well aware of the means of "putting over the story" in an interesting and understandable way and have, indeed, shown an astonishing aptitude for this and other publicity work.

For newcomers, then:

Send out your invitations to your local Press in good time and address them to the News Editor in each case. Remember that a Tuesday is probably the best day for a Press visit to a forest; it suits the daily paper and ensures that the local weekly reporter, usually a man with numerous other diary engagements, has time before publication day to do justice to his story and secure for it the maximum available space. Remember that some reporters may not have had an earlier opportunity to acquire any background forestry knowledge, and see that a simple and short explanatory "handout" is available and includes, for accuracy's sake, the salient figures. DON'T describe species in the handout, or verbally when on tour, as, for example, S.P., C.P. or J.L. and so on. Give the trees their full names in English, otherwise the reporter may not have a clue to what you are talking about. The same goes for such cryptic references as "P.28" or "Prep. ground", both of which mean a lot to you but absolutely nothing to the visitor.

Concentrate on showing the major features of the forest; if you give an acreage, it is always "newsy" to give an astronomical number of trees planted or to be planted. Don't keep the Press too long on the job—some reporters may have other engagements later the same day, so that a start at, say, 11.30 a.m. with termination of the tour at 3.30 p.m. is usually adequate. Don't treat your guests as "professional" hikers; I remember a threat by a Forester to a party of Pressmen that he intended after lunch to march up over the hill for four miles, to obtain the "finest views from any forest". Needless to say, there was alarm and despondency, removed only by contrition on the Forester's part and the use of a Land-Rover. Always start the tour with a little elucidation of what is to be seen and its importance, and take advantage of the lunch break to give a resume of what has gone before, and to invite questions.

The importance of the help we obtain from the provincial and local Press, particularly in putting amenity matters into perspective and where fire publicity is concerned, cannot be overstressed. There is no space here in which to list the various tours that have been held of late; all, even the smallest attended, were of value. One might perhaps mention one of the more ambitious, which was held early in 1958 in the Border National Forest Park and coincided with the publication of the new Guide to the area. Much space was given to the event and 1,500 copies of the Guide were sold in the first seven weeks of its appearance.

Newspaper Articles: Broadcasting

A number of Officers are adept at producing articles for which a useful "home" can be found in local newspapers. These will always be welcomed, for they usefully supplement the flow of material which emanates from Headquarters. Such articles should not exceed 1,000 words, and the more references that are included to local forests and name-places the better, for this will assure the interest of a number of different local papers with varying circulation areas.

From time to time our Officers are asked to broadcast, either in the sound programmes or on television, and the skill shown in this direction has been quite striking. In one B.B.C. Region the Conservator broadcasts on forestry aspects regularly each month in a popular "round-up" feature, while other officers have in the last year or so taken part in discussions or special countryside programmes. There is, unfortunately, little that can be said for the guidance of the potential broadcaster, for so much depends on the nature of the programme. Whatever is said he will, of course, suffer from "microphone nerves" but while these may be apparent to the broadcaster, rarely indeed are they visible to the audience. There is comfort in the fact that B.B.C. and I.T.V. producers have an amazing facility, born of long experience, for making the "victim" feel at home.

One might mention here the benefits that arise from the B.B.C.'s more recent policy of giving local news bulletins each evening, for they are an excellent medium for forest news; in arranging the Press tours already referred to it is worth while including the Regional B.B.C. News Editor in the list of invitees. He won't come himself, of course, but in most instances he will send a representative or arrange for one of the local newspaper reporters to send him some "copy". Similarly, Independent Television News could also be included—if any difficulty arises in ascertaining the names of the right broadcasting people to approach I shall be only too pleased to advise, on request.

With the growth in ownership of T.V. sets it is inevitable that we should hope for more opportunities to use this powerful publicity medium. True, we have been able to secure the inclusion of forestry on a number of occasions and three times to date have we provided a feature for the B.B.C. T.V. Farming Programme—from Radnor Forest, where the association of agriculture and forestry was demonstrated; from South-West England to show how best farm woods can be treated; and Ponterwyd and elsewhere in mid-Wales to demonstrate the benefits of shelter on the farm when the trees are also planted for timber production. Nevertheless, a real problem arises in trying to obtain more T.V. time for forestry. Competition is so fierce that no Information Officer in any Department can lay hand on heart and say he is yet content, by any means. In one aspect, in my opinion, the advent of commercial television has perhaps not been entirely desirable for it has meant by its very competitive nature that the B.B.C. must enter the fields of variety and entertainment and popular quiz, largely to the exclusion of educational features. We can but continue to crusade.

Showing the Flag at Agricultural Shows

Other publicity work to which field officers make a most valuable contribution is the staging of exhibits at agricultural shows, often in conditions made somewhat difficult by limitation of expenditure. It must, however, gratefully be placed on record that, despite problems, our show programme has steadily expanded, while the quality of the exhibits arranged by the Conservancies—and indeed, we think, the travelling exhibit—has been such as to win high praise from the show organisers and the general public. There is no doubt whatever that Conservancy efforts have brought great credit to the Commission as well as achieving their object, which is to educate the woodland owner and the potential planter of trees and to interest and enlighten the general public. It is impossible, without special equipment, accurately to record the number of visitors to the Commission's displays at shows, but the travelling display alone is thought to be seen by a quarter of a million people each year.

Lectures offer a useful opportunity for spreading the forestry gospel and here our Forest Officers are helping considerably, speaking at several hundred meetings each year. The association and co-operation with local schools, too, is undoubtedly paying dividends, judging by the number of schools which are undertaking forestry projects of one kind or another, albeit often of an elementary character. Some schools have taken over portions of Commission forests for educational purposes and it is hoped that this sort of thing will develop still further. Trees given by the Commission where surplus to our requirements, have been issued by the thousand for planting in school grounds as long-lasting reminders of the industry practised by the donors. At the time of writing I am busy producing a pamphlet, supplementary to "Starting a School Forest", which will offer guidance to the school which, having neither regular access for geographical reasons to a Commission forest, and without any land of its own in which to plant trees, may yet wish to study forestry. It is to be entitled "Forestry and the Town School".

Students from Teachers' Training Colleges have been going regularly to the forests under the escort of our Officers and obtaining a useful look at forestry, a glimpse which will no doubt serve to inspire them, when in post, to instruct the younger generation in the importance of trees.

An Acknowledgment

Press, broadcasting, shows, exhibitions, liaison with schools and educationalists, the giving of lectures and the showing of films, no matter what the media, have in the past offered an opportunity to the Forest Officer to "display his wares". Indeed, without his assistance the work of the Commission would be much less widely known than it is today and I would place on record my thanks for the generous support that is always so readily forthcoming from the field.

LET US SEE IT IN PRINT

By H. C. CRAWFORD

Clerical Officer, Publications Branch

Yes, and why not let us see those thoughts, those ideas, those experiences of yours in print? It may be that you have something to tell that others would like to know about. Perhaps it is a new ploughing technique which you have been practising, or an idea you have on planting methods or forest management. Perhaps you have constructive views on thinning, felling, fencing, forest office

procedure; anything that you would like to tell to a larger audience than your own small circle of colleagues. Often, your colleagues have not the time or the inclination to listen to your ideas, but *we* have; in the Publications Branch we read anything and everything. As long as it is down on paper and sent to us we will read it and if the material is good; publish it. That is our job; we are always on the look-out for "copy" which will subsequently become printed and useful to forestry in general. "Publications" is an auxiliary of "Research" and it is the business of this branch to publish, not only the findings of the Research Forest Officer, but also the findings of anybody connected with forestry, so long as it serves the promotion of forestry.

You may think that what you have to say isn't sufficient material to be worth printing. Are you sure it is not worth printing? You might be wrong in thinking that. Although your contribution may not be of so technical a nature as to warrant publication as a "Forest Record" it might be of such general interest for publication in our "Journal". Very few contributions accepted by the *Journal of the Forestry Commission* are lengthy manuscripts and rarely exceed 2,000 words in length, most of them are less than a thousand. This article, for instance, consists of 800 words.

We know that within the Commission there must be practices—I don't mean illegal practices, we would rather not know about those—but practices which are useful and which if others knew of them would make for greater efficiency. As for ideas that have formulated in the minds of many of our forest fraternity, these must run into thousands, but, unfortunately, we do not get to hear of them, so they just stay unheard of and untold to the general forester at large.

Recently someone walked into our office to enquire of our Editor, who by the way, has written many books on forestry practice and is most qualified and willing to make an article out of any matter sent in, so long as it has substance worth telling—as I was saying, this person walked into our office and asked the opinion of the Editor concerning the uses of different types of bill-hooks. The enquirer wanted the information to assist him in his studies into the prevalence of accidents within the Commission and their causes. He said that accidents on duty involved the Commission in thousands of pounds in payment of compensation and that he was making a survey with the intention of putting forward suggestions for lowering the accident rate. It seemed to us that here was material for an article in the *Forestry Commission Journal*, so he was asked to find us some notes suitable for publication (see pages 110 - 115).

In what way do we want you to express your ideas or your particular knowledge so as to be readable? Do we want your article to be a perfect piece of prose, with thoughts set out in logical sequence paragraph by paragraph to end with a concise summing up? No, not necessarily. We do, of course, like to receive such material, but from our experience articles very rarely come to us without needing a good deal of editing. What we want, is material with some substance, something of which we can say, "Here are some ideas"! "Here are some facts"! "Here are some experiences"! All worth reporting and therefore something for us to work on, something we can put into shape if it is necessary. As long as your notes—you may call them that if you wish—have something to tell us and which would be worth telling to others, then the Editor will see that those notes go to press in good order and will turn out presentable to others when they are finally read in print. It is these articles that make our "Journal", and the more varied they are, the more popular it will become. So let us see what you have to say. Send us the thoughts you have been pondering for so long and *let us see it in print*.

**LIST OF FINDS FROM STAPLE HOWE,
SCARDALE FOREST, SENT TO THE BRITISH MUSEUM**

Contributed by T. C. H. BREWSTER

In the *Journal* for 1958, we published a full account of the excavations at the important prehistoric site of Staple Howe, in Scardale Forest, Yorkshire. To complete the story, we give below a list of "finds" that have now been sent to the British Museum in London.

LIST OF STAPLE HOWE FINDS, BRITISH MUSEUM

Bronze objects

- 1 single looped razor.
- 1 double looped razor.
- 1 fragmentary bronze razor.
- 1 chisel with tang.
- 1 broken chisel tang.
- 1 pair of tweezers.
- 1 small ferrule.
- 1 awl (large).
- 1 awl (small).
- Several fragments of sheeting, pins, etc.

Weaving equipment

- 18 complete spindle-whorls of pottery.
- 20 fragments of clay spindle-whorls.
- 1 spindle-whorl of chalk.
- 5 clay loom-weights which can be reconstructed and fragments of many others.

Stone Objects

- 7 stone pounders and remains of others.
- 6 stone "rubbers".
- Remains of several hones including example with squared corners.
- 6 tools and implements of flint.
- Remains of stone celt used as a "rubber".

Bone objects

- 4 gorges.
- 3 complete netting shuttles and remains of another.
- 7 pins, or awls, and many fragments of similar finds.
- 1 scoop.
- 1 decorated scoop.
- 2 antler "picks" or levers.

Jet objects

- 1 pendant.
- 2 beads.
- 3 nearly complete rings and parts of several more.
- 8 fragments of bangles.
- 2 "buttons" or beads, rectangular in shape.
- Several worked pieces of jet and small fragments of ornaments.

Marine shells, etc.

Several mussel, winkle, limpet and cockle shells.
1 shark's tooth.

Grain

Several hundred grains of carbonised wheat.

Wood

Samples of carbonised wood from the hearths and palisades.

Bones

Many thousands of bones of horses, dogs, sheep, pigs, oxen and beaver, etc.
Human skull from palisade.

Pottery (excluding weaving equipment)

750 rim and feature (sherds?).

Many thousands of pot (sherds?). The "count" is not yet completed, possibly 100,000 to a million fragments.

1 pottery spoon or scoop.

1 95 per cent complete oval vessel, possibly a lamp.

1 50 per cent complete oval lamp.

Several vessels should be reconstructed from the fragments recovered.

FIRETOWER AT EMERY DOWN, NEW FOREST

By R. H. PACKWOOD

Acting Chief Engineer

The photograph shows a fire-observation tower, recently completed in the New Forest. It is unusual in that it is triangular in plan, the three legs being of Douglas fir obtained in the forest close at hand, and creosoted by a specialist firm in nearby Southampton. (Plate 10, Central Inset.)

The height is 70 feet from ground level to cabin floor, that being the desirable minimum at the site for radio communication, as well as clear observation over the treetops.

This tower replaces one of similar height which also was constructed from local timber, and was triangular in plan. Two of its three legs rotted internally through the ingress of water creeping along horizontal bolt-holes, and special precautions have been taken to prevent this happening with the new tower.

Another feature of the new tower is that the legs stand on (not in) concrete pedestals, and therefore all their length is above ground level. They are secured to pairs of steel joists embedded in the concrete and projecting about 2 feet 6 inches above the surface. Should poles rot at the point of contact, repairs can be simply and cheaply effected. (Plate 9, Central Inset.)

The legs are stiffened by heavy bracers, aided by substantial timber landings. The work of erection was carried out by the engineers of South-West Conservancy, to the designs of the Deputy Chief Engineer, for England, Col. R. Packwood. Work was seriously impeded by heavy rain, but the tower was ready for service for the 1959 fire season.

This tower exemplifies the fact that up to 70 feet, and possibly even 80 feet, there is seldom need to use steel. On the contrary, from several points of view including comfort of the users, cost and harmonious appearance, there is everything to commend the use of timber, especially when it can be derived from the Commission's own forests.

POSTSCRIPT TO THE SCOTTISH WOODLANDS CENSUS, 1947-49

By A. M. MACKENZIE
District Officer, Research Branch

We have traversed the woodlands of Caledon
From Cape Wrath to the Solway shore
We have measured the sites where the remnants stand
And the wastes which were forest before.

We have followed the trail o'er the Caithness Ord
Through the Ross-shire glens to Kyle
Along the haughs of the Dee and the Spey
To Rannoch, then down Argyll.

We have come from the woods of the Western Isles
By the carse of Gowrie and Clyde
Through the Kingdom of Fife, and the Lothians three
To Ayr moors and the Machars beside.

Then onwards through Peebles, Selkirk, Dumfries
Till from merse and dale convened
At the Cheviots and Tweed our labour was stayed
With a million acres gleaned.

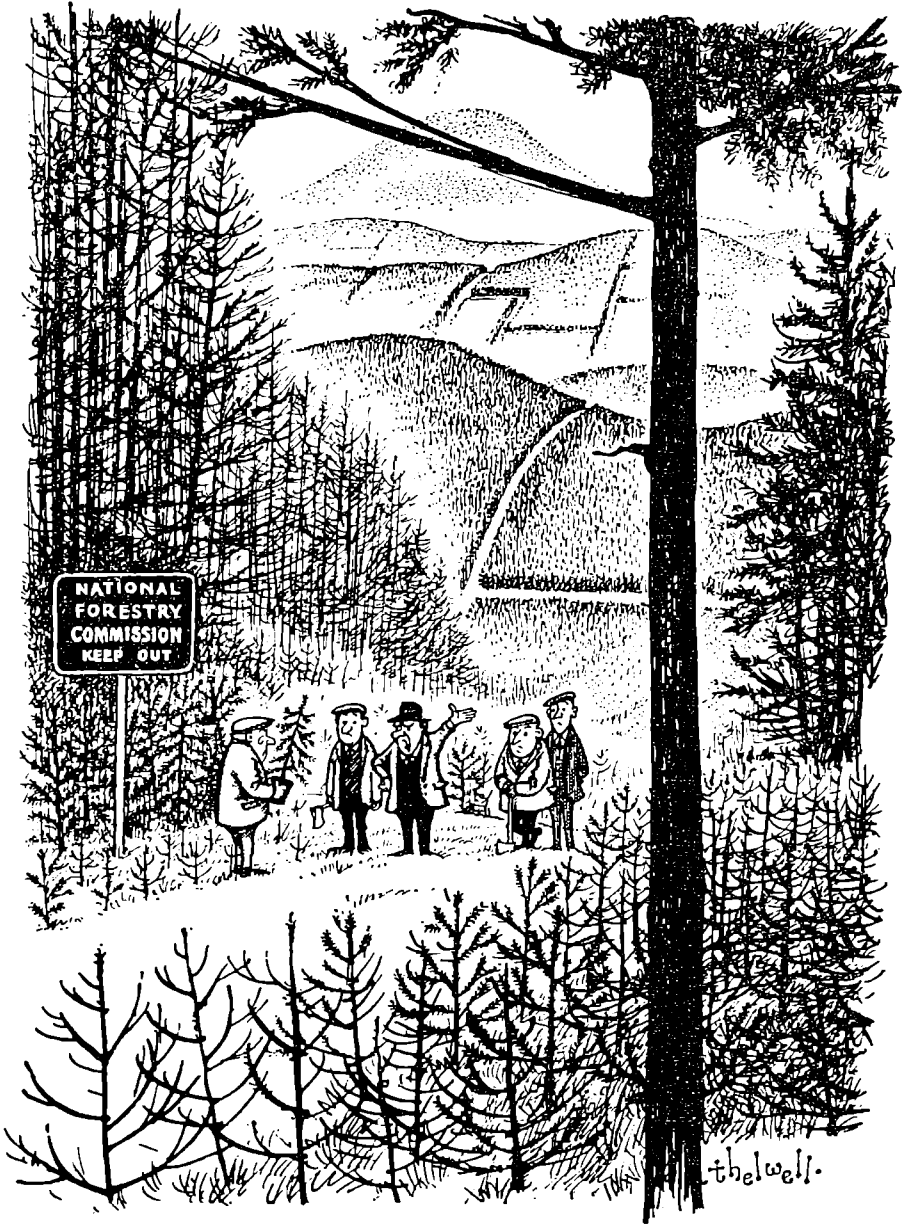

Fig. 70. "Bringing it back isn't the point! Supposing we'd *all* decided to borrow one for Christmas. *Then* what?"

Reproduced by kind permission of Thelwell and the News Chronicle.

FORESTRY COMMISSION STAFF

At 1st January, 1959

Notes: The stations of individual officers are shown only where they are different to that of their main office. This list should not be read as a seniority list; it has been compiled from returns submitted by the various offices to the Establishment Section.

HEADQUARTERS: 25 SAVILE ROW, LONDON, W.1

TELEPHONE: REGENT 0221

CHAIRMAN:	The Earl of Radnor, K.C.V.O.
DIRECTOR-GENERAL:	Sir Arthur Gosling, K.B.E., C.B.
DEPUTY DIRECTOR-GENERAL:	Sir Henry Beresford-Peirse, Bt., C.B.
SECRETARY:	H. A. Turner
CHIEF ENGINEER:	W. S. Catlow
CONSERVATOR:	Mackenzie, G. I.
DIVISIONAL OFFICER:	Zehetmayr, J. W. L., Edinburgh (Work Studies)
DISTRICT OFFICER I:	Forrester, S. (Machynlleth) " "
DISTRICT OFFICERS II:	Crowther, R. E. (Newcastleton) " " Dannatt, N. (Coed y Brenin) " "
FORESTER:	Kirkland, C. P. (Newcastleton) " "
ASSISTANT FORESTERS:	Davenport, J. G. (Gwydyr) " " Toulmin-Rothe, L. P. (Coed y Brenin), " "
PRINCIPALS:	Coggins, W. E., O.B.E.; David, M. L.
CONTROLLER OF FINANCE:	Cormack, W. M.
SENIOR CHIEF EXECUTIVE OFFICER:	Shanks, E. C.
CHIEF EXECUTIVE OFFICERS:	Charters, H., M.B.E.; Lewis, Cmdr. E. R., V.R.D. Minter, A. F.
PRINCIPAL INFORMATION OFFICER:	Healey, D.
SENIOR EXECUTIVE OFFICERS:	Butcher, J., M.B.E.; Hyem, H. G.; Shepcott, M. P.; Wharam, J. B. (Gwydyr) (Work Studies).
HIGHER EXECUTIVE OFFICERS:	Alison, Mrs. M. E.; Brown, F. J.; Carvosso, L. A.; Doherty, W. R.; Evans, W.; Flowers, H. R.; Grinter, L. C.; De Groote, A. M.; Harper, J.; Hermon, P. F.; Mills, B. V.; Overy, J. S. V.; Preston, J.; Summers, J. J. V.; Westcott, A. B.; Wright, S. T.
WELFARE OFFICER:	Gower, E. (H.E.O.).

EXECUTIVE OFFICERS

Beard, G. C.; Bell, R. J. (Edinburgh); Breslin, C.; Brewer, A. E.; Brook, P. W.; Cartwright, Miss I. E.; Chapman, A. B.; Cruden, S.; Drew, Miss P. M.; Eden, Miss M. J.; Frost, Miss D. M.; Grinsted, L. H.; Hinds, E. S. J.; Johnson, Miss E.; Mattock, A. C. S. (Alice Holt); Mogford, J. W. M.; Norton, J. F.; Pearson, W. E.; Pettitt, A. G.; Pritchard, J. G.; Simmonds, C. W. (Newcastleton); Smith, A.; Stutter, N. E.; Terry, Miss J. F.; Turner, C. L.; Wagg, H. O.; Wilbraham, H. P.; Wittering, W. O. (Edinburgh); Wotton, R.

DIRECTORATE FOR ENGLAND

Office of Director: 1 Princes Gate,
London, S.W.7.

Telephone: Kensington 9691

DIRECTOR:	G. B. Ryle.
CONSERVATORS:	C. A. J. Barrington; S. W. Edwards (Estate).
DIVISIONAL OFFICERS:	Kennedy, J. B. (Sales); Stocks, J. B.
DIRECTORATE ENGINEER:	Packwood, R. H.
MECHANICAL ENGINEERS:	Fitzpatrick, G. (Lightmoor, Dean Forest); Richardson, M. C.
WORKSHOP MANAGER:	Gawn, S. (Lightmoor, Dean Forest)
SENIOR CHIEF EXECUTIVE OFFICER:	Palmer, A. D.
SENIOR EXECUTIVE OFFICER:	Barter, L. G.
SENIOR PROFESSIONAL ACCOUNTANT:	Wharton, K.
HIGHER EXECUTIVE OFFICERS:	Baldwin, F. C. (Estate); Brimmer, S. H.; Buck, A.; Horsham, Miss J.; Manicom, Miss M. E.; Morley, R. M.
GAME WARDEN:	Fooks, H. A. (Grizedale).
DRAUGHTSMAN (HIGHER GRADE):	Axtell, R. A.

EXECUTIVE OFFICERS

Brown, E.; Carter, K. W.; Crerar, Miss E.; Grove, R. C. S.; Henry, H.;
Loverock, E. G. (Lightmoor); McRitchie, J.; Mitchell, Miss A. S.;
O'Shaughnessy, Miss S. E. M.; Peal, Miss M.; Pidgeon, Miss A. M.; Powell, E. S.;
Round, G. L.; Trist, J. D.; Worthington, Mrs. E. E.; Yates, Miss M. D.

ENGLAND, NORTH-WEST CONSERVANCY

Upton Grange,
Upton Heath, Chester,
Cheshire.

Telephone: Chester 24006-7-8

CONSERVATOR:	J. S. R. Chard.
DIVISIONAL OFFICERS:	Conder, E. M.; Grant, D.; Raven, W. J. (Estate).
DISTRICT OFFICERS I:	Coulson, T. W. G. (Lichfield); Crosland, J. V. (Kendal); Flynn, A. E. C.; Jackson, W. V. (Mansfield); Roberts, W. G. (Shifnal).
DISTRICT OFFICERS II:	Fletcher, J. R. (Bakewell); Leslie, J. E.; Malcolm, D.C. (Craven Arms); Michie, E. J. S. (Carlisle); Mitchell, T. C.; Orrom, M. H. (Kendal); Raban-Williams, R. (Estate); Winchester, P. L. (Cockermouth).
CONSERVANCY ENGINEER:	Phillips, W. M.
MECHANICAL ENGINEER:	Haynes, W. S.
ASSISTANT ENGINEERS:	Hughes, R. E. (Kendal); Tennant, G. V. (Carlisle).
CLERKS OF WORKS:	Adams, C. (Ennerdale); Bayne, D. L. (Kershope); Clark, J. (Thornthwaite); Cotterell, C. J. (Mortimer); Goodwin, W. A. (Clipstone) (Estate); Manning, P. H., (Ambleside) (Estate).
SENIOR EXECUTIVE OFFICER:	Steele, J.
HIGHER EXECUTIVE OFFICER:	Scarle, A. J.

EXECUTIVE OFFICERS

Ainsworth, S.; Armstrong, J. G.; Butt, A. A.; Dominey, C. H.; Lloyd, H.; Simpson, W. V.;
Watts, J. E.

HEAD FORESTERS

Adams, I., Mortimer; Daghish, T. E., Sherwood; Walton, W., Thornthwaite.

FORESTERS

Allcock, M. S., Hardknott; Anderson, R. D., Greystoke; Atkinson, I. D., Miterdale; Attenborough, T. J., Long Mynd; Axtell, D. W., Cannock; Barraclough, J. W., Matlock; Bennett, H., Delamere; Bignell, R. A., Launde; Brandon, J. W., Mortimer; Brooke, B. L., Kinver; Brown, D., Kershope; Close, F., Grizedale; Coates, W. E., Grizedale; Davis, P. P., Arden; Day, J., Charnwood; Francis, E. R., Cartnel, Foulshaw, Lyth; Fuller, H., Blengdale; Garner, W., Sherwood; Grant, W., Thornthwaite; Guthrie, F. H., Kershope; Gwilliam, G. T. S., Beeston; Hall, D., Cannock; Hall, W., Sherwood; Harvey, D. R., Sherwood; Harvey, K. B., Longtown; Jenkins, T. L., Delamere; Jones, E., Inglewood; Keens, D. W., Dalton; Macdonald, R., Mortimer; MacKenzie, J. H., Causeway Wood; MacMillan, J. R., Swynnerton; Morgan, L. G., Cannock; Morley, D. S., Grizedale; Morrill, W. H., Hope; Morris, J., Mortimer; Murray, M., Bowland; Nelson, D., Ennerdale; Pemberton, F., Spadeadam; Power, R. J., Thornthwaite; Rees, T. J. R., Walcot; Rowlands, I. G., Sherwood; Sarsby, O. R., Sherwood; Shelley, W. R., Mortimer; Stickland, H. F., Sherwood; Stokoe, J., Habberley; Thomas, D. R., Sherwood; Tucker, E. J., Corvedale; Walsh, D. H., Thornthwaite; White, S. L., Sherwood; Wilson, W. J., Bagot; Wood, P., Oakamoor; Woollard, R. P. C., Bawtry.

ASSISTANT FORESTERS

Aspinall, E., Delamere; Bartholomew, W., Grizedale; Birch, F. C., Mortimer; Bollard, W. A., Cartmel; Brunton, J., Dalton; Colling, J. B., Bowland; Collings, P. J. B., Cannock; Dean, B. G., Swynnerton; Edwards, K. T., Thornthwaite; Hall, J. R., Kershope; Harpin, J. W., Sherwood; Hawkes, D. M., Kershope; Hobbs, A. B., Sherwood; Hobson, K. A., Kershope; Hutchinson, P., Mortimer; McKay, H., Kershope; Moore, T. B., Mortimer; Morris, R., Packington; Newsom, G. B., Gisburn; Patten, B. D., Kershope; Parker, J. A., Walcot; Simpkin, J. R., Mortimer; Thick, F. W., Cotgrave; Thompson, B. S., Greystoke; Tisdall, J. C., Foremark; Tyler, W. H. S., Sherwood; Ward, A. A., Sherwood; Williamson, F. L., Thornthwaite; Windle, D., Dalton; Wood, D., Grizedale; Yates, H., Ennerdale.

FOREMEN

Bowes, A., Kershope; Coates, F. H., Sherwood; Flint, W. H., Cannock.

ENGLAND, NORTH-EAST CONSERVANCY

Briar House,
Fulford Road,
York

Telephone: York 24684

CONSERVATOR: G. J. L. Batters
 DIVISIONAL OFFICERS: Dent, T. V.; Portlock, W. J. J. (Estate); Smith, W. T., Hexham.
 DISTRICT OFFICERS I: Langley, P. J., Hexham; Maund, J. E.; Piper, R. J. (Estate); Rowan, A. A., Rothbury; Selby, B. C.; Semple, R. M. G., Kielder.
 DISTRICT OFFICERS II: Barrett, F. D.; Bell, H. W., Pickering; Curwen, J. G., Kielder; Hurst, R. T., Helmsley; Laurie-Muir, J., Kielder; MacDonald, I. A. D.; Marshall, I. R. B.; Rix, A., Durham; Thallon, K. P., Helmsley; Voysey, J. C., Wakefield.
 CONSERVANCY ENGINEER: Preston, G. W.
 MECHANICAL ENGINEER: Wortley, A.
 ASSISTANT ENGINEERS: Allan, C. S., Bellingham; Basse, T., Bellingham; Bromley, A. R.

CLERKS OF WORKS:

Blankenburgs, V., Kielder; Buller, H. B., Wark; Cuthbert, T., Falstone; Kelly, J. H., Redesdale; Kirby, C., Allerston (Estate); Knott, C. E., Allerston; Lees, W. R., Kielder (Estate); Morgan, J. F., Helmsley; Symonds, A. J., Kielder.

SURVEYORS:

Grant, V., Widehaugh; Jackson, G. S., Pickering.

SENIOR EXECUTIVE OFFICER:

Chaplin, L. A.

HIGHER EXECUTIVE OFFICER:

Blott, J. C.

EXECUTIVE OFFICERS

Henry, W.; Hickleton, G. A.; Palmer, R.; Roscoe, K.; Taylor, K. H. C.; Walker, J. A.; Wallis, Miss B. E.

HEAD FORESTERS

Gough, W. R., Allerston; McCavish, W. L., Redesdale; Sharp, G. A.; Snowdon, L., Allerston; Stoddart, W. F., Rothbury.

FORESTERS

Adams, G., Cleveland; Ainsworth, P. H., Holmfirth; Baird, R. L., Markington; Bartlett, R. F. E., Allerston; Bewick, T., Slaley; Bolam, T. W., Rievaulx; Bowns, A., Hambleton; Brown, W. C., Wark; Charlton, E., Widehaugh; Chisholm, J. D., Langdale; Collier, T. E., Wark; Cumming, J., Jervaulx; Fawcett, E., Londesborough; Featherstone, C., Ampleforth; Fowler, N. L., Ray; Fox, T. F., Kielder; France, J., Wharnccliffe; Gilson, R. B., Harrogate; Gledson, J. G., Rothbury; Harbin, W. B., Wynyard; Hird, J., Arkengarthdale; Hislop, J. J., Harwood; Johnstone, T., Hambleton; Judge, J. N., Redesdale; Marsh, E. W., Redesdale; Marshall, J. A., Hamsterley; Martindale, J. M., Helmsley; Mennell, J., Langdale; Metcalfe, J. E., Plashetts; Parker, G. W., Chopwell; Phelps, S. E., Selby; Salmond, M. P., Doncaster; Scott, G. H., Cropton; Scott, J. J. O., Kielder; Simpson, C. N., Kielder; Stanley, W. E., Langdale; Stephenson, F., Ampleforth; Stokoe, G., Slaley; Straughan, J. G., Wark; Tait, J., Kielder; Taylor, C. E., Cleveland; Telford, J. W., Chillingham; Terry, T. N., Rosedale; Thompson, L. T. J., Kielder; Turnbull, M. T., Kielder; Wheeler, R. T., Rothbury; Woodcock, F. A., Kidland; Woodward, F. G. Scardale; Young, J. P., Widehaugh; Young, R. E., Kielder.

ASSISTANT FORESTERS

Allen, M. J. J., Allerston; Bardy, D. A., Harwood; Barry, G. N., Chopwell; Clark, P. F., Langdale; Clarke, J., Wark; Conduit, J. S., Kielder; Craig, J. M.; Davison, A., Knaresborough; Dawson, K. J., Allerston; Edes, D. S., Harwood; Featherstone, P., Redesdale; Fisher, H., Allerston; Hammond, D., Pundershaw; Hartley, A.; Haw, G., Rosedale; Heaven, S. F.; Hodgson, M., Ampleforth; Holden, R. L., Kidland; Lancaster, R. A., Allerston; Lewis, D. I., Wynyard; Long, T. W., Hamsterley; Manning, N. L. B., Knaresborough; Marchant, R. E., Jervaulx; Maughan, B., Rothbury; Miles, M. B., Wynyard; Mills, K., Londesborough; Mobbs, I. D., Kielder; Moules, T. R., Rosedale; Richardson, I., Chirdon; Robinson, P. D., Hamsterley; Scott, T. I., Redesdale; Simpson, G., Rosedale; Stonehouse, F., Langdale; Straughan, W., Redesdale; Webster, F., Cawthorne; Weir, A. H., Kielder; Wilbert, G. M., Kielder; Williams, R. D., Allerston.

FOREMEN

Atkinson, J., Rosedale; England, T., Ampleforth; Ruston, R. N., Allerston.

ENGLAND, EAST CONSERVANCY

Brooklands Avenue,
Cambridge
Telephone: Cambridge 54495

CONSERVATOR:	G. W. Backhouse
DIVISIONAL OFFICERS:	Ballance, G. F.; Good, F. G. (Estate); Payne, S. R.
DISTRICT OFFICERS I:	Chapman, E. S. B., Hitchin; Chard, R.; Davidson, J. L., Princes Risborough; Halton, K.; Harker, M. G.; Kennedy, K. N., Ipswich; Mackay, D., Aylsham.
DISTRICT OFFICERS II:	Derrick, R. G., Grantham; Kirton, I. W., Thetford; Lapage, C. J. (Estate); Pryce, T.; Small, D., Thetford; Searle, H., Lincoln; Stoakley, J. T., Princes Risborough; Tilney-Bassett, H. A. E., Aylsham; Walker, A. D., Halstead; Wildash, J. T., Northampton.
CONSERVANCY ENGINEER:	Cook, G. O.
CLERKS OF WORKS:	Foote J., Rockingham (Estate); Holmes, W., Thetford (Estate); Raisborough, R., Tunstall (Estate).
FOREMAN SURVEYOR:	Elliott, H., Thetford.
SENIOR EXECUTIVE OFFICER:	Clark, G. H.
HIGHER EXECUTIVE OFFICER:	Affleck, R. J.

EXECUTIVE OFFICERS

Carter, W. A.; Damerell, A. F.; Folkes, K. A. B.; Merker, P. A.; Threadgill, J. S.; Wild, A. H.; Wood, J. H.

HEAD FORESTERS

Anderson, J. T., Thetford; Button, G. H., Swanton; Heavener, C., Princes Risborough; Redford, C. W., Thetford; Wellington, C. R., Rendlesham; Wyatt, L., Hazelborough; Williams, J., Rockingham.

FORESTERS

Acott, E. J., Rockingham; Adams, H., Elveden; Axten, G. B., Thetford; Beard, B. W., Ampthill; Birkitt, A., Rendlesham; Bloor, C. A., Yardley; Booth, E. M., Whaddon Chase; Burnie, H. W., Thetford; Clark, J. F., Rockingham; Deal, W., Holt; Dover, A. C., Chilterns; Faddy, A. C., Salcey; Field, H. C., Thetford; Gracie, A., Thetford; Hall, V. B., Wigsley; Harker, A., Rockingham; Hardy, R. B., Kesteven; Hendrie, J. A., Thetford; Hinton, F. I., Bramfield; Hutchings, D. R., Honeywood; Ingram, L. D., Thetford; Irons, E. R., Ditton; Johnson, H., Chilterns; Jones, F. B., The King's Forest; Jones, G., Bardney; Keeler, B., Bernwood; King, S. G., Thetford; Law, S. J., Thetford; Lawson, G. E., Thetford; Leutscher, E. H., Thetford; Ling, J., Laughton; Liddington, G., Hazelborough; Marshall, D. F., Willingham; Marston, W. H., Thetford; Mitchell, A. L., Kesteven; Morris, A. M., Rockingham; Moulden, D. J., Walden; Muggleton, H. G., Swanton; McLeod, E., Gaywood; Parker, J. W., Dunwich; Parlett, H. F., Hevingham; Pritchard, R., Swaffham; Pywell, A. C., Burwell; Roberts, G., Thetford; Robinson, D. A., Thetford; Salisbury, E. J., Thetford; Schofield, R., Chilterns; Shinn, F., Thetford; Smith, W. P., Shouldham; Steel, W. H., Tunstall; Stott, W. S., Walsham; Trussell, J., Chilterns; White, J. B., Lavenham; Williams, J. H., Thetford; Woodrow, R. B., Thetford; Yeomans, F. W. J., Thetford.

ASSISTANT FORESTERS

Arbon, A. A., Walden; Banks, P. A., Harling; Belton, G. C., Thetford; Beverley, E., Bardney; Boughton, M. J., Fermyn; Butcher, A. J., Wigsley; Carter, D. E., Apethorpe; Cavell, E. W., Honeywood; Chandler, R. H., Pytchley; Dampney, C. F., Tunstall; Ellis, D. E., Amphill; Fulcher, D. E., Apethorpe; Gordon, B. S., Swaffham; Hampstead, E. V., Hevingham; Hobbs, G., Bardney; Howarth, J., The King's Forest; Hunt, L., Lavenham; Kew, F. M., Tunstall; Kirby, P. D., Holt; Lane, P. B., Gaywood; Marsh, P., Swanton; Mitchell, W. P., Waveney; Nichols, A., Yardley; Nicholson, J. H., Rockingham; Patterson, D. T., Kesteven; Payne, W. G., Amphill; Platt, B. F. W., Marlow; Roebuck, B. A., Willingham; Rogers, E. V., Huntingdon; Rouse, R. S., Bernwood; Shaw, J. K., Roundham; Snowden, J. D., Thetford; Southgate, G. J., Hazelborough; Sturges, B. W., Kesteven; Wainwright, J. D. F., Elveden; Ward, J. A., Chilterns; Waters, C. G., Dunwich; Wilson, A. L., Waveney and Brooks Woods; Wilson, B., Kesteven; Wiseman, J., Rendlesham; Wood, P., Didlington; Woods, A. J., Bramfield.

FOREMEN

Basham, T. F., Thetford; Brown, C. S., Rendlesham; Manels, R. W., Thetford; Marsh, L. E., Thetford; Pickwell, H., Laughton; Rutterford, D., Thetford.

ENGLAND, SOUTH-EAST CONSERVANCY

"Danesfield",
Grange Road,
Woking
Telephone: Woking 2270-1-2

CONSERVATOR: R. H. Smith.
DIVISIONAL OFFICERS: Dixon, E. E.; Garthwaite, P. F.
DISTRICT OFFICERS I: Burton, E. S. V., Winchester; Keen, J. E. A., Reading; Mithen, D. A., Ashford; Snook, K. R. (Estate); Sutton, A. R., Chichester; Troup, L. C., Guildford; Weston, F., Winchester; Wilson, J. F. (Acquisition).
DISTRICT OFFICERS II: Boyd, D. B., Reading; Cooper, D. J., Sevenoaks; Cuthbert, A. A., Ashford; Gradwell, J. W. (Estate); Joslin, A.; Kipling, T. H., Chichester; Perry, D. J., Reading; Spencer, A. J., Uckfield; Verey, J. G. H., Uckfield.
CONSERVANCY ENGINEER: Crawford, P. C. R.
CLERK OF WORKS: Arnold, J. M.
SENIOR EXECUTIVE OFFICER: Gulliver, H. W.
HIGHER EXECUTIVE OFFICER: Bowman, L. W.

EXECUTIVE OFFICERS

Channon, E. T.; Godfrey, Mrs. D. M.; Hall, Mrs. A. M.; Hansford, E. G.; Hill, G. J.; Rolfe, A. W.; Walker, S.

HEAD FORESTERS

Brook, J. W., Slindon; Davies, D. J., Hemsted; King, B. H., Hursley; Lingwood, N. J., Bramshill.

FORESTERS

Arnott, W., Andover; Aston, T. H., Challock; Cooper, J. H., Bedgebury; Cross, L. G. F., Alice Holt; Davy, J. H., Rogate; Francis, R. E., Chiddingfold; Hyett, S., Shipbourne; Laney, H., Queen Elizabeth Forest; Middleton, W. F. C., Arundel; Watkins, S., Lyminge; Awberry, P. P., Southwater; Barden, J. T., St. Leonards; Barling, F. C., Vinehall; Bashall, J. R. C., Orlestone; Brinsley, D. A., Bramshill; Catchpole, R. A., Micheldever; Cooper, J., Marden; Cordery, E. B., Maresfield; Drake, F. H., Alton; Forrest, A. H., Witley; Freeth, A. J., Bishopstoke; Hann, F. G., Abinger; Henderson, J. R., Brightling; Holter, G. E., Friston; McNamara, N. A. G., Bramshill; Moseley, J., Hemsted; Pyman, A. G., Micheldever; Spiller, G. D., Lyminge; Taylor, A. F., Bramshill; Trodd, K. H. C., Gravetye; Twallin, R. W., Shere; Usher, F., Havant; Vickery, F. J., Mildmay; Watkinson, R. V., Bucklebury; Watts, F. C., Bere; Woods, W., Basing.

ASSISTANT FORESTERS

Batt, C. J., Lyminge; Bignell, R. A., Bere; Budgen, E., Brightling; Cale, G. F., Queen Elizabeth Forest; Choules, C., Friston; Davies, W. J., Bedgebury; Davys, J. P., Andover; Devine, R., Badbury; Dineen, P. J., Bramshill; Green, G. G., Alice Holt; Griggs, B., Hursley; Harding, D., Alton; Hinds, C. H., Rochester; Hoblyn, R. A., Alice Holt; Howell, W. R., Hemsted; Kennard, J. T., Effingham; Langford, D., Charlton; Lawes, R. F., Bere; Marples, D., Abinger; Meek, W. T., Challock; Monk, R. F., Orlestone; Newland, R. L., Bramshill; Oakes, R., Charlton; Parnall, D. L., St. Leonards; Pearce, P. H., Micheldever; Percy, D. M., Hursley; Perkins, R. M., Mildmay; Rickards, S. W., Slindon; Russell, M. J., Bucklebury; Stemmmons, S. W., Mildmay; Smith, H. J., Arundel; Sutton, B. E., Hursley; Tyers, J. D. A., Brightling; Vine, S. V., Bedgebury; Vines, R. C. B., Challock; Wainwright, R., Vinehall; Wood, I. E., Chiddingfold.

FOREMAN

Butcher, H. C., Crawley.

ENGLAND, SOUTH-WEST CONSERVANCY

Flowers Hill,
Brislington,
Bristol, 4

Telephone: Bristol 78041-5

CONSERVATOR: C. A. Connell
 DIVISIONAL OFFICERS: Penistan, M. J.; Rouse, G. D.
 DISTRICT OFFICERS I: Carnell, R.; Cotter-Craig, T. D., Tavistock; MacIver, I. F., Malvern; Purser, F. B. K., Salisbury; Rogers, S. W., Exeter; White, A. H. (Estate).
 DISTRICT OFFICERS II: Banister, N., Taunton; Blatchford, O. N., Dorchester; Clothier, C. R. G.; Kellie, J., Bodmin; Moir, D. D., (Estate); Oram, A. K., Launceston; Scott, A. H. A., Dorchester; Shirley, M. C., Gloucester.
 CONSERVANCY ENGINEER: Perkins, J. S.
 MECHANICAL ENGINEER: Inglis, E. J.
 ASSISTANT ENGINEERS: Martin, D. R., Taunton; Orton, G. R., Launceston; Shillito, P. E.
 CLERKS OF WORKS: Boundy, L. D., Exeter (Estate); Coon, W. J., Launceston; Inglis, R. E., Haldon; Labram, W. J., Brendon.
 SENIOR EXECUTIVE OFFICER: Coote, R.
 HIGHER EXECUTIVE OFFICER: Tinson, E. F. J.

EXECUTIVE OFFICERS

Carter, L. W.; Child, Miss A. V.; Cutcliffe, B. W. J.; Lane, E. C.; Maher, Mrs. B. M.; Musto, A. F.; Redd, F. C.

HEAD FORESTERS

Beasley, G. F., Okehampton; Cameron, A. H., Herodsfoot;
Gunter, A. T. G., Hereford; Hollis, G. W., Tiverton; Parsons, F. G., Wareham;
Smith, J. J., Haldon.

FORESTERS

Barber, E. G., Gardiner; Beard, A. C., Dymock; Bowdler, T. C., Haldon;
Bowman, P., Bodmin; Braine, R. G., Wareham; Bruce, J. M., Eggesford;
Bultitude, R., Hartland; Chapman, S., Brendon; Clarke, H. F., Molton Woods;
Coles, L. H., Collingbourne; Cox, D. J., Charmouth; Dyer, H. C., West Woods;
Everitt, E. C. W., Stanway, Cowley; Everitt, F. W., Puddletown; Fairman, E., Mendip;
Fife, R. G., Dartmoor, Fernworthy; Fowler, J., Neroche, Sedgemoor; Fulford, A. G., Glynn;
Green, W. J., Blandford; Hammond, B. R. G., Moccas, Aconbury;
Hockaday, C., St. Clement; Humphries, W. J., Bowerchalk, Salisbury;
Jane, T. A., Bruton, Shepton; Jenkinson, G. A., Quantocks; Law, H. G., Wyre;
Lewis, C. J., Savernake; Linder, R., Radio duties; Link, H. H., Dymock;
McIntyre, N. E., Bentley; Mills, E. W., Savernake; Parker, J., Brendon;
Parsons, P. H., Dartmoor; Poll, E. A., Haldon; Scammell, R. L., Honiton;
Sherrell, D. A., Halwill; Skinner, F. C., Haugh; Spencer, A. H., Stokeleigh;
Strong, T. G., Herodsfoot; Tackney, A. J., Wareham; Walsh, J. E., Halwill;
Walton, R., Purbeck; Whale, R. S., Plym, Erme; Williams, L. H., Taunton;
Wills, K. G., Bradon; Wilson, M. J., Middlemarsh.

ASSISTANT FORESTERS

Anderson, J. E., Wareham; Ayers, D., Bentley; Barton, E. N., Mendip;
Bibby, W. B., Pershore; Budden, R. C., Halwill; Chalmers, J. G., Dartmoor;
Devine, T. D., Wareham; Douglas, G. S., Eggesford; Dyer, W. F., Halford;
Flagg, G. D. St. J. B., Stanway; Fox, F. G., Bruton; Gould, J., Wyre;
Grenfell, R. G. P., Wilsey Down; Grosfils, L. F., Lydford; Hall, M. P., Bradon;
Hambly, J. R., Glynn; Hibberd, E. C., Neroche; Houghton, M. A., Hartland;
Humphrey, A. W., Honiton; James, M. E. H., Neroche; King, R. J., Pershore;
Lansdown, P. W., Blandford; Lewis, W. P., Poorstock; Miles, R. B., Quantocks;
Millman, M. R., Honiton; Morrish, F. C., Blandford; Murphy, B. M., Haldon;
Pound, H. L., Brendon; Rayner, G. L., Bampton; Scaife, R. G., Bodmin;
Simkins, G., Bradon; Snell, D. G., Haldon; Snellgrove, D. S., Mendip;
Sturgess, W. F., Savernake; Taylor, G., Plym; Thurlow, F. G., Quantocks;
Tilley, J. W., Wyre; Trotter, W., Plym; Whitlock, M. D., Savernake; Scott, M. J., Quantocks.

FOREMEN

Bowles, W. J., Fernworthy; Gale, A., Wareham.

ENGLAND, NEW FOREST

The Queen's House,
Lyndhurst,
Hants.

Telephone: Lyndhurst 300

DEPUTY SURVEYOR:

E. Wynne-Jones

DISTRICT OFFICERS I:

Simmonds, S. A. (Estate); Winterflood, E. G.

DISTRICT OFFICERS II:

Harrison, J. C.; Munro, N. S., Ringwood; Pullinger,
R. A.

CLERK OF WORKS:

Partridge, A. G. (Estate).

HIGHER EXECUTIVE OFFICER:

Watson, W. G.

EXECUTIVE OFFICERS

Foard, W. H.; Ingram, Miss W. H.; Kennedy, D. A.; Parker, E. G.

HEAD FORESTERS

Adams, J. H.; Liddell, J.; McNab, C., Ringwood; Parry, A. A., Isle of Wight; Young, H. C.

FORESTERS

Campbell, I. R., Shalfleet; Cuff, E. W.; Fletcher, R.; Green, F. J.; Holloway, A. T.; Hindley, N. H., Brighstone; Hodgson, R. S., Ringwood; James, A. L.; James, H. B. S.; Meech, R., Ferndown; Perkins, D. E. S., Ferndown; Reece, A. V.; Roe, W. T.; Sainsbury, B. H., Hurn; Stirrat, J. B., Ringwood; Thomas, T. J. H.; Wood, J. F. B.; Yerbury, E. S., Parkhurst.

ASSISTANT FORESTERS

Allison, C. E.; Christmas, S. E. V.; Coutts, A. A.; Dunning, A. R.; Evans, W. C., Brighstone; Everard, J. E., Hurn; Fox, K. W., Combley; Goodson, P. B.; House, D. H.; Howard, D. J., Ringwood; Moore, W.; Stone, P. L.

HEAD KEEPERS

Breakspear, A.; Humby, J.; Smith, B. B.

ENGLAND, FOREST OF DEAN

Whitemead Park,
Parkend,
Nr. Lydney, Glos.

Telephone: Whitecroft 305-6

DEPUTY SURVEYOR:	R. G. Sanzen-Baker
DEPUTY GAVELLER, MINES:	Herdman, H. P.
DISTRICT OFFICERS II:	Cameron, J. D.; Hewitt, R. M.; Jardine, J. (Estate); Wardle, P. A.
CLERKS OF WORKS:	Bradbeer, F. G.; Yemm, C. F. (Estate).
SURVEY CLERK:	Hill, J. F. (Estate).
EXECUTIVE OFFICERS:	Gubby, M. A. E. (Chief Clerk); Whiting, E. F.

HEAD FORESTERS

Jennings, J.; Watson, F.

FORESTERS

Daniels, P. R.; Davies, C. H.; Davis, S.; Dick, C. R.; Falconer, I. A.; Freeman, J. E. D.; Jones, H.; Lee, J. J.; Lewis, A. E.; Middleton, J. W.; North, S. J.; Parry, H. M.; Roberts, G.; Russell, C. F.

ASSISTANT FORESTERS

Garry, A. C.; Brain, J. S.; Dunn, M. J.; Heathcote, J. F.; McCreath, N. F.; Pugh, T. C.; Ricketts, G. A.; Sharp, H. O.; Taylor, G. E.; Venner, B. G.; Westacott, W. D.

DIRECTORATE FOR SCOTLAND

Office of Director: 25 Drumsheugh Gardens,
Edinburgh, 3

Telephone: Edinburgh Caledonian 4782

DIRECTOR :	A. Watt
CONSERVATORS :	J. P. Mackie Whyte (Estate); Maxwell, H. A.
DIVISIONAL OFFICER :	Innes, P. A.
DISTRICT OFFICERS I :	Graham-Campbell, D.; Legard, P. H.; Seal, D. T.
DISTRICT OFFICERS II :	Forbes, D. F. C.; Jackson, R. d'O. P.
DIRECTORATE ENGINEER :	Beaton, D. M.
MECHANICAL ENGINEER :	Blane, J. W.
ASSISTANT ENGINEER :	Anderson, W. C.
SENIOR CHIEF EXECUTIVE OFFICER :	McGeorge, T. H.
SENIOR EXECUTIVE OFFICER :	MacKenzie, M. E. W.
HIGHER EXECUTIVE OFFICERS :	Bisset, J. T.; Burnett, A. G.; Geekie, Miss J.; Jones, N. R.; Sticks, Miss J.

EXECUTIVE OFFICERS

Armstrong, A. T.; Brown, H. M.; Carstairs, J. D.; Davis, J. W.; Eadie, T. L.; Hogarth, J.; Massie, J. M.; Mitchell, Miss J. P.; Pringle, D. P.; Stevenson, G. F. K.; Swinburn, K.; Wightman, Miss J. L. H.; Wilson, Miss I. J.

DRAUGHTSMAN (HIGHER GRADE): Williams, V. H.

SCOTLAND, NORTH CONSERVANCY

60 Church Street,
Inverness

Telephone: Inverness 223, 608-9

CONSERVATOR :	J. A. Dickson.
DIVISIONAL OFFICERS :	Chrystall, J.; Crawford, A. R.; Gascoigne, C. A. H. (Estate); Innes, R. A.
DISTRICT OFFICERS I :	Fraser, A. M.; Mackay, A. F., Dingwall; Macleod, D., Dingwall.
DISTRICT OFFICERS II :	Cassels, K. A. H. (Estate); Drummond, J. A., Fort Augustus; Grant, I. A. D., Dornoch; Macrae, F. M., Leanachan; Massey, J. E., Glenurquhart; Morrison, A., (Acquisition); Ogilvie, J. Y., Leanachan; Paterson, D. B.; Ray, A., Fort Augustus; Savage, G. F., Fort Augustus; Taylor, G. G. M., Dingwall.
CONSERVANCY ENGINEER :	MacKillop, E. R.
MECHANICAL ENGINEER :	Ross, R. B.
ASSISTANT ENGINEERS :	Davidson, K. T., Fort Augustus; Thompson, G. M., Dingwall.
CLERKS OF WORKS :	Baxter, W.; Dargie, J. H., Dingwall; Fraser, G., Inverness (Estate); MacLennan, A., Inchnacardoch; Noble, A., South Laggan; Ward, A. A., Glen Affric; Whitby, W. B., Inverinate.
SURVEYOR :	Urquhart, T.
SENIOR EXECUTIVE OFFICER :	Nicolson, M.
HIGHER EXECUTIVE OFFICER :	MacBeath, T. S. B.

EXECUTIVE OFFICERS

Birrell, A. J.; Collins, V. M.; Edward, C.; Ettles, W.; Fyfe, J.; Henderson, F. S.; Oswald, A.

HEAD FORESTERS

Macdonald, C., Isle of Skye; Macdonald, D., Inchnacardoch;
Mackay, A., Glen Affric, Guisachan; Mackenzie, J., Sunart, Glen Cripesdale, Glen Hurich;
Maclean, A., Ardrross; Macleod, D. J., Dornoch;
Macrae, D. J., Balblair, Craigs, Oykel, Shin; Murray, W., Black Isle.

FORESTERS

Beattie, W. R., Battan; Brown, R. S., North Strome; Cameron, W. J., Glen Loy;
Campbell, R. W., Leanachan; Carmichael, D., Fiunary; Crawford, A., Oykel;
Dyce, W. J. P., Clach Liath; Fell, J. B., Urray; Fraser, T., Creag nan Eun;
Frater, J. R. A., Glen Righ; Galt, T. J., Slattadale; Gordon, J., Ferness, Laiken;
Grant, J. D., Glen Garry; Laird, D. M., Clunes; Lawson, W. M., Balblair;
Lockhart, W. H., Glen Hurich; Macallan, F., South Strome; McClymont, W., Strath Conon;
MacIntosh, W., Borgie, Strathy; MacKay, H., Craigs;
MacKay, J., Achnashellach, Achnasheen; MacKay, J. A., Salen;
MacKay, W., Culloden, Craig Phadrig; MacKenzie, A., Assich; Maclean, A. R., Shin;
Maclean, K. A., Naver; Macpherson, W., Glen Affric; Macrae, H., Lael;
Morris, H. D., Nevis; Morison, A. W., Kessock; Munro, G., Glen Urquhart;
Murray, A. R., Aigas; Murray, R., South Laggan; Nicolson, W. J., Findon;
Officer, A. W., Port Clair; Phipps, N., Strath Nairn; Riddell, J. M., Farigaig;
Robertson, D. D. C., The Queen's Forest; Ross, D., Millbuie; Scott, J., Rumster, Dunnet;
Scott, M. P., Inverinate; Small, G., Morangie; Smith, D. R., Ratagan, Glen Shiel;
Stobie, F. D., Torrachilty, Longart; Sutherland, D. R., Strath Dearn;
Sutherland, R. W., Strath Mashie; Taylor, C. A., Kilcoy; Thom, A. B., Inshriach;
Watson, J. C., Ceannacroc.

ASSISTANT FORESTERS

Auld, J. B., Glen Urquhart; Baird, T. L., Glen Brittle; Beaton, D. A., Millbuie;
Boustead, J., Dornoch; Cameron, T., Sunart; Campbell, D., Glen Righ;
Chree, J. W., Eilanreach; Denholm, J., South Strome; Douglas, R., Salen;
Evans, R., Farigaig; Forsyth, A., Port Clair; Fraser, L. A., Findon; Gibson, A., Torrachilty;
Gordon, J., Kilcoy; Graham, G., Kilcoy; Grant, D., Healaval; Grant, W. M., Leanachan;
Henderson, A. A., Glen Garry; Howard, R. L., Oykel; Hunter, W., Shin;
Kay, E. R. M., Morangie; Macdonald, J., Strath Conon; MacDougall, D. A., Glen Hurich;
MacInnes, A., Sunart; MacInnes, D. F., South Laggan; McIntosh, D. C., Leanachan;
MacKay, J. W., Boblainy; MacKinnon, J., Culloden; Mackintosh, J. A., Glen Loy;
Mackintosh, L. W., Salen; MacIennan, D., Slattadale; Macleod, J., Inshriach;
Millar, J., Ceannacroc; Morrison, I. C., Fiunary; Munro, A., Millbuie;
Murdoch, R. K., Strath Mashie; Nicol, A., Salen; Patience, J. J., The Queen's Forest;
Patience, W. M., Glen Affric; Reid, G. W. M., Guisachan; Reid, H. R., Ardrross;
Richardson, J. G., Ardrross; Saunders, E., Inchnacardoch; Taylor, J. W., Ratagan;
Thom, H., Inchnacardoch; Thomson, R., Glen Urquhart.

FOREMEN

Cameron, W. G., Inshriach; Campbell, J. Raasay; Elder, J. C., Leanachan;
Fraser, S., Craig Phadrig; Macbeth, H., Strath Dearn; Macleod, W., Lael;
Macpherson, C., Achnashellach; Macrae, M., Ratagan; Mann, W., Millbuie;
Stuart, R., Culloden.

SCOTLAND, EAST CONSERVANCY

6 Queen's Gate,
Aberdeen
Telephone: Aberdeen 33361

CONSERVATOR:	F. W. A. Oliver
DIVISIONAL OFFICERS:	Bennett, A. P. (Estate); Dier, H. V. S.; Horne, R. J. G.; Petrie, S. M.
DISTRICT OFFICERS I:	Chrystall, J. G., Brechin; Donald, F. J., Fochabers; Fergusson, J. L. F., Perth; Haldane, W. D., Brechin; Kennedy, J. A. M., Forres; Watt, I. S., Perth; Wood- burn, D. A., Dunkeld.
DISTRICT OFFICERS II:	Bearhop, A., Perth (Estate); Cathie, R. G., Fochabers; French, W. F., Kemnay; Jeffrey, W. G., Brechin; Larsen, R. T. F., Dunkeld; McIntyre, P. F., Dinnet; Whayman, A.
CONSERVANCY ENGINEER:	Blenkinsop, R. I. C.
ASSISTANT ENGINEERS:	Chapman, F. G., Perth; Walker, P. H. F.
CLERKS OF WORKS:	Clark, J. D., Roseisle; Forbes, C., Bin; Logan, G. McF., Perth; Rothnie, W., Drumtochty.
SENIOR EXECUTIVE OFFICER:	Lenman, J. P.
HIGHER EXECUTIVE OFFICER:	Reid, J. L.

EXECUTIVE OFFICERS

Albiston, I. A.; Angus, J.; Cowan, A. A.; Dunford, J. A.; Furneaux, D.; Hendry, D. L.;
Stoddart, Miss E. N.

HEAD FORESTERS

Allison, R. A., Speymouth; Corbett, J., Craig Vinean; Gilbert, G., Durris;
Kennedy, J. M., Drummond Hill; McDonald, W., Drumtochty; Milne, W. G., Culbin;
Murray, G. J. A. M., Glen Livet; Urquhart, D. J., The Bin; Watt, D. M., Monaughty.

FORESTERS

Allan, J., Edensmuir; Anderson, D., Clashindarroch; Anderson, F., Benachie;
Biggar, A. W., Elchies; Christie, J. H., Glen Livet; Douglas, W. S., Whitehaugh;
Ellen, R. M., Blairadam; Ewen, B. A., Kemnay; Fraser, J. R., Clashindarroch;
Garrow, P. J., Rannoch; Grigor, E., Glenisla; Grubb, J. A., Newton;
Guild, J., Montreathmont; Harwood, A. E., Blairadam; Hyslop, R. M., Kirkhill;
Hepburn, N. R., Hallyburton; Innes, G. C., Midmar; McBain, G. L., Fetteresso;
McDowall, C., Pitfichie; Mackay, W., Inglismaldie; McIntosh, W. J., Tornashean;
Mackintosh, C. O., Speymouth; McLeod, E., Roseisle; McRae, J., Scootmore;
Marnoch, D., Alltcaillach; Masson, V., Blackcraig; Maxtone, J. R., Rosarie;
Mitchell, F. M., Carden; Murray, G. M. W., Drummond Hill; Pennet, H., Rosarie;
Reid, J., Tentsmuir; Reid, J. G. M., Fochabers; Reid, J. K., Fonab; Rose, A., Ledmore;
Russel, J. C., Kinfauns; Scaife, C. L., Lossie; Seaton, J. A., Teindland;
Skene, W. F., Dalgaty; Stewart, G., Speymouth; Stewart, S. W. R., Keillour;
Stuart, P., Newtyle; Thomson, R. B., Craig Vinean; Thow, G. B., Glendoll;
Thow, J. B., Forest of Deer; Watt, W. J., Allan; Webster, J. O., Blackhall;
Wilson, J. F., Pitmedden.

ASSISTANT FORESTERS

Adam, R., Hallyburton; Aitken, R. G., Monaughty; Amer, D. J., Culbin;
Anderson, W. B., Newton; Armstrong, P., Bin; Bain, J., Rannoch; Bowie, A. G., Bin;
Davidson, A. L., Monaughty; Elliott, D. M., Inglismaldie; Gordon, W. J., Blackhall;
Greenless, C. V., Drummond Hill; Johnston, W., Drumtochty; Jolly, J. Mc., Glenerrochty;
Kemp, W. T., Cushnie; Kingham, H. A., Clashindarroch; MacCallum, L. C., Speymouth;
McConnachie, K., Glen Livet; McLean, J. P., Ledmore; Macmillan, T. W., Drumtochty;
MacPhee, H. A., Fetteresso; Menzies, J. D., Rannoch; Rose, J., Alltcaillach;
Thirde, G. S., Glenisla; Tracy, C. R., Drumtochty.

FOREMEN

Anderson, R. M., Tentsmuir; Anderson, S. C., Keillour; Brown, R., Craig Vinean; Grant, A. M., Elchies; McCann, W. G., Drummond Hill; McDonald, J., Culbin; Salmean, C., Glendevon; Soppit, J., Montreathmont.

SCOTLAND, SOUTH CONSERVANCY

Greystone Park,
Moffat Road,
Dumfries

Telephone: Dumfries 2425-6-7

CONSERVATOR:	J. A. B. Macdonald.
DIVISIONAL OFFICERS:	Fossey, R. E.; Gibson, W. N.; Donald, R. R.
DISTRICT OFFICERS I:	Brown, N. M., Peebles; Golding, R. A., Barr; Johnson, W. A. J. (Estate); Long, M., Moffat; MacNab, J. D., Newton Stewart; Stirling, J., Moffat; Wilson, K. W., Dalry.
DISTRICT OFFICERS II:	Fergusson, W. S., Dalbeattie; Findlay, T. S. L., Newton Stewart (Estate); Neustein, S. A., Moffat; Robertson, S. U., Gatehouse of Fleet; Steel, R. P., Longniddry; Williams, M. R. W., Jedburgh.
CONSERVANCY ENGINEER:	MacMahon, C. D.
ASSISTANT ENGINEERS:	Clarkson, W. H.; McNulty, E. P., Jedburgh; Ruthven, G., Newton Stewart.
CLERKS OF WORKS:	Carmichael, J. H., Bonchester Bridge; Dalgleish, T., New Galloway; Fergusson, J. M., Kirkcudbright; Johnston, F. (Estate); Muir, W., Newton Stewart; Shaw, A.; Smith, W. B., Straiton.
SURVEYOR:	McMillan, J. G.
SENIOR EXECUTIVE OFFICER:	Farmer, T.
HIGHER EXECUTIVE OFFICER:	Elliott, J. W.

EXECUTIVE OFFICERS

Byth, J. G.; Griffin, J.; Halliday, Miss A.; Jackson, G. K.; Laidlaw, J. C.; Morley, G. J.; Roberts, E. G.

HEAD FORESTERS

Cameron, D. M., Dundough; Graham, A., Mabie; Mackay, W. H., Fleet; MacMillan, H., Kirroughtree; MacRae, A. D., Glen Trool; Parley, C. W., Cairn Edward; Reid, J. M., Ae; Watson, J., Dalbeattie.

FORESTERS

Anderson, M., Wauchope; Armstrong, H. O., Bareagle; Broll, J. L., Yair Hill; Campbell, D., Cairn Edward; Carruthers, J., Fleet; Carruthers, M. F., Dreva; Chisholm, M. R., Carrick; Cochrane, A. S., Dalmacallan; Davidson, J. R., Duns; Drysdale, N., Carrick; Duncan, D., Wauchope; Edward, R. M., Brownmoor; Gallacher, J. M., Clauchrie; Gallacher, P., Glen Trool; Goodlet, G. A., Newcastleton; Gutch, J. H. M., Stenton; Harvey, T. S., Ae; Harkness, J. R., Castle O'er; Hart, R. B., Kilgrammie; Hunter, J., Greskine; Jamieson, R. A., Newcastleton; Kirk, D. M., Kirroughtree; Leishman, A., Changue; Lloyd, S., Laurieston; McDonald, J. D., Glentress; McGeorge, R., Ae; McGivern, W., Edgarhope; McNicol, F., Wauchope; McNaught, D. J., Arecleoch; Melville, J., Selm Muir; Murray, W., Glengap; Park, H. C. B., Glen Trool; Parker, J., Glen Trool; Parkinson, J. W., Auchenroddan; Patterson, B., Garcrogo; Peddie, A. S., Cardrona; Rae, W. R., Mabie; Robertson, D., Kilsture; Robertson, W. J., Clydesdale; Scott, J. F., Craik; Slater, J., Saltoun; Swan, R., Watermeetings; Thomson, A., Dalbeattie; Thomson, J., Penninghame; Towns, K. W., Cairn Edward; Urquhart, G., Elibank and Traquair.

ASSISTANT FORESTERS

Bagnall, J. A., Ae; Bagot, W., Changue; Beaton, J., Kirroughtree;
 Bowdler, A. C. F., Cairn Edward; Brooks, C., Penninghame; Burgess, W., Mabie;
 Burgon, F. W., Cairn Edward; Cooper, B., Ae; Cooper, J. A. M., Glen Trool;
 Dinsdale, E., Ae; Edwards, O. N., The Garraries; Fligg, P., Carrick;
 Fraser, J. McD., Wauchope; Graham, P. Carrick; Grieve, W. J., Fleet;
 Hogg, J. L., Kirroughtree; Hope, T. C., Fleet; Jordan, R. D., Dundough;
 Lawson, J., Elibank; Liddell, A. T., Glentress and Eddleston; McArthur, A., Carrick;
 McBurnie, A., Ae; McIntyre, C., Dalbeattie; McClelland, P. W., Glen Trool;
 MacKenzie, P., Corriedoo; MacNeill, J. B., Glen Trool; Mowat, P., Newcastleton;
 Murray, D. M., Bareagle; Murray, T. M., Cairn Edward; Nelson, T., Glengap;
 O'Brien, G. D., Carrick; O'Mara, J. P., Greskine; Paterson, W. G., Ae;
 Pearce, J. S., Kirroughtree; Pickthall, H., Cairn Edward; Priestley, P. E. B., Wauchope;
 Ramsay, K. J., Castle O'er; Reid, J. M., Dalbeattie; Semple, W. K. L., Dundough;
 Taylor, J. W., Glen Trool; Thomas, A. F., Cairn Edward; Veitch, T. H., Newcastleton;
 Walsham, J. A., Laurieston; Watson, A., Upper Nithsdale; Waugh, D. E., Craik;
 Wood, R. A. L., Kirroughtree.

FOREMEN

Harris, R. C., Glengap; Maxwell, N., Cairn Edward; Wilbur, G., Dalbeattie;
 McCleary, A., Cairn Edward.

SCOTLAND, WEST CONSERVANCY

20 Renfrew Street,
 Glasgow, C.2

Telephone: Douglas 7261-2-3-4

CONSERVATOR: J. E. James
 DIVISIONAL OFFICERS: Davies, E. J. M.; Robbie, T. A.
 DISTRICT OFFICERS I: Gillespie, I., Cairnbaan; Macpherson, M., Barcaldine;
 Murray, G. K.; Stewart, I. J.; Sutherland, W. B.,
 Benmore; Thomson, W. P., Stirling; Townsend, K. N. V.,
 Knapdale.
 DISTRICT OFFICERS II: Dey, G. A., Cairnbaan; Goodlet, J. A., Benmore;
 Gwyn, J. M., Cairnbaan, Knapdale; Illingworth, R. P.,
 Benmore; McGarva, J. F., Benmore; Macnair, A. S.,
 Aberfoyle; McNeill, I., Stirling.
 CONSERVANCY ENGINEER: Green, A. M.
 MECHANICAL ENGINEER: Atkins, F. C.
 ASSISTANT ENGINEERS: Gibson, W., Aberfoyle; McLachlan, R. W., Benmore;
 Nisbet, J. D., Cairnbaan, Knapdale.
 CLERKS OF WORKS: Auld, J. M., Glenbranter; Bennett, D., Aberfoyle;
 Lamb, J. S., Benmore (Estate); McDougall, H., Barcaldine
 (Estate); McKellar, D. L., Cairnbaan (Estate);
 McLay, J. D., Aberfoyle (Estate); Meek, I. G. N.,
 Benmore; Miller, R., Ardgartan; Robertson, J. R.,
 Barcaldine; Stark, W., Cairnbaan.
 SURVEYOR: Sturrock, W. G., Cairnbaan.
 SENIOR EXECUTIVE OFFICER: Kinnaird, B.
 HIGHER EXECUTIVE OFFICER: McMillan, W.

EXECUTIVE OFFICERS

Brown, R. G.; Brunton, I. A.; Clelland, Mrs. I.; Liddell, A.; Macniven, Miss B.;
 Sifton, J. G. F.; Stewart, W.

HEAD FORESTERS

Calder, J. M., Carron Valley; Cameron, A., Strathyre; Crozier, R., Inverliever;
Fairbairn, W., Devilla; Fraser, E. D., Loch Ard; Kennedy, J., Minard;
Mackay, A., Barcaldine; MacKinnon, H., Knapdale; Murray, R. G., Glenbranter.

FORESTERS

Allan, J. S., Strathyre; Angus, R. S., Glenfinart; Beaton, K. A., Torrie;
Campbell, W. W., Loch Ard; Cramb, J., Glenduror; Cunningham, A. J., Leapmoor;
Dye, W. E., Ardfin; Francey, C. S., Ardgartan; Fraser, T. S., Rowardennan;
Gilles, A., Glenbranter; Gilmour, W., Inverliever; Hamilton, J., Benmore;
Harland, J., Benmore; Henderson, W., Loch Ard; Irving, R. H., Aberfoyle;
Jackson, J., Benmore; Johnston, C. R., Garelochhead; Keiller, W., Carron Valley;
Lawson, D. W., Tulliallan; MacCallum, D., Achaglachgach; MacCaskill, D. A., Lennox;
MacFadyen, D., Inverliever; McGeachie, R., Strathyre; MacGregor, D. R., Ardgartan;
MacKay, D. J., Asknish; MacKay, J. F., Glenfinart; McKeand, J. W., Inverliever;
Mackenzie, I., Inverinan; McLarty, H. C., St. Fillans; McLean, A., Kilmichael (South);
McLean, R., Kilmory; McMillan, A., Devilla; McMillan, J., Minard;
McNicol, I., Barcaldine; McNicol, P., Inverinan; MacPhee, C. J., Fearnoch;
MacRae, D. J., Ardgartan; McRorie, J. P., Glenrickard; Martin, W. C., Creran;
Morrison, A., Carradale; Morrison, N., Corlarach; Munro, D., Carradale;
Polwart, A., Strathyre; Rattray, W. D., Garadhban; Robertson, D. A., Knapdale;
Robertson, N., Tighnabruaich; Rodger, J., Inverinan; Ross, D. H., Loch Ard;
Ross, I., Kilmichael (North); Simpson, A. A. C., Carradale; Sinclair, L., Glenduror;
Stout, H. C., Glendaruel; Stuart, A. M., Loch Eck; Young, A., Strathlachlan.

ASSISTANT FORESTERS

Beaton, J., Loch Ard; Blake, G. W., Glenduror; Cairns, J. M., Loch Ard;
Calder, A. M., Loch Ard; Campbell, M. M., Loch Ard; Carr, I., Garadhban;
Cowie, F. R., Ardgartan; Cruickshank, A., Strathyre; Elgar, W., Garelochhead;
Ferguson, P. D., Glenbranter; Fraser, J. M., Glenduror; Fryer, K., Glenbranter;
Gelder, J. S., Benmore; Graham, A. W., Lock Eck; Graham, H., Knapdale;
Hart, C. W., Inverliever; Harvey, R., Benmore; Lyon, J. H. M., Tulliallan;
MacCallum, D., Kilmichael; MacDuff, R. J. A., Barcaldine; McDonald, W., Inverliever;
McGavin, J. N., Glenfinart; McIntosh, A., Strathyre; McKenzie, J. S., Saddell;
McLaughlin, R. S., Loch Ard; McLeod, N., Loch Eck; McNair, J., Knapdale;
MacRae, D. J., Glenduror; Main, D., Inverinan; Maule, S. G., Glenbranter;
Morrison, I., Inverliever; Murray, J. T. H., Asknish; Oliphant, R., Glenfinart;
Proctor, W. A., Strathyre, Devilla; Proudfoot, L. O., Devilla; Queen, T. S., Glenduror;
Robertson, J. D., Loch Ard; Ross, D. A., Kilmichael; Sallie, J. L. T., Achaglachgach;
Sanders, P. R. W., Garshelloch; Shaw, N., Rowardennan; Sinclair, D., Inverliever;
Smellie, A., Knapdale; Solway, D. F., Glenfinart; Turner, A. S., Glenbranter.

FOREMEN

McEachern, J., Achaglachgach; Rose, W., Strathyre.

DIRECTORATE FOR WALES

Office of Director: Victoria House,
Marine Terrace,
Aberystwyth

Telephone: Aberystwyth 367

DIRECTOR:	J. R. Thom
CONSERVATOR:	Forrest, G.
DIVISIONAL OFFICER:	Cadman, W. A.
DISTRICT OFFICERS I:	Holtam, B. W., Ruthin; Morgan, P. W.; Peaty, C. E., Llandrindod Wells.
DISTRICT OFFICERS II:	Grabaskey, B. P., Narberth; Robertson, D. Y. M., Cardiff; Wallace, D. H.
DIRECTORATE ENGINEER:	Mullowney, V. L.
CHIEF EXECUTIVE OFFICER:	Taylor, G. F.
HIGHER EXECUTIVE OFFICERS:	Edwards, F. L. G.; Pope, H. J. (Estate); Salaman, D. O. J.

EXECUTIVE OFFICERS

Baldwin, K.; Barcham, F. C.; Fisher, D. C.; Hunt, T. G.; Latham, F. C. B.; Owen, E. G.; Pruce, K. E.

WALES, NORTH CONSERVANCY

15 Belmont,
Shrewsbury
Telephone: Shrewsbury 4071-2

CONSERVATOR: F. C. Best.
 DIVISIONAL OFFICERS: Arends, A. W. (Estate); Godwin, G. E.; Hampson, J. R.
 DISTRICT OFFICERS I: Hughes, B. D., Llandrindod Wells; Keighley, G. D.,
Oswestry; Lindsay-Smith, W. A., Gwydyr; Osmaston,
J. F., Dolgelley; Spencer, J. A., Ruthin.
 DISTRICT OFFICERS II: Guile, A. W. L., Bangor; Herbert, R. B., Ruthin;
Hooper, H. J. (Estate); Hughes, D. M., Oswestry;
Overell, P. A. W., Llandrindod Wells; Pinchin, R. D.,
Bala; Saunders, H. J.; Skinner, J. R., Aberystwyth;
Stern, R. C., Dovey; Walbank, B., Welshpool; Webb,
F. H., Aberystwyth.
 CONSERVANCY ENGINEER: Philbrick, G. E. H.
 MECHANICAL ENGINEER: Low, W. L.
 ASSISTANT ENGINEERS: Baylis, D. O., Aberystwyth; Egerton, F. C., Gwydyr;
Yates, R. W. P., Cemmaes.
 CLERKS OF WORKS: Bollans, L., Gwydyr (Estate); Dummett, E. J., Gwydyr;
Griffiths, W. E., Dovey (Estate); Redford, H., Hafren;
Vincent, P. E., Dovey; Woodier, C., Ystwyth (Estate).
 SURVEYORS: Price, C. C., Gwydyr; Williams, L. V., Dovey.
 SENIOR EXECUTIVE OFFICER: Mayhew, K.
 HIGHER EXECUTIVE OFFICER: Bowers, G. H.

EXECUTIVE OFFICERS

Clay, J.; Fisher, R. H.; Frost, H. S.; Hamilton, B. A.; Smith, H. G.; Tudor, Miss M. C.; Winter, K. W.

HEAD FORESTERS

Davies, A. I., Clocaenog; Evans, J. E., Taliesin; Harrison, P., Gwydyr;
Hughes, A., Coed y Brenin; Jones, A., Beddgelert; Jones, E. T., Ystwyth; Jones, J. T., Hafren;
Lomas, J., Lake Vyrnwy; Yapp, P. W. C., Radnor.

FORESTERS

Bell, H. C., Dovey; Bowen, J. F., Elwy; Butterworth, P., Radnor; Carlaw, R. S., Dovey;
Claydon, G. W., Breidden; Daniel, C. E., Gwydyr; Davies, P. G., Halcyn;
Edwards, R., Coed y Brenin; Evans, A. C. W., Kerry; Evans, J. F., Llŷn; Farrelly, F., Clwyd;
Gardner, E. C. C., Coed y Brenin; Griffiths, E., Myherin; Griffiths, I. L., Dovey;
Griffiths, O. G., Coed y Brenin; Griffiths, R. W., Môn; Harrison, P. G., Penllyn and Glanllyn;
Hopkins, C. J., Carno and Bechan; Hughes, J. W., Rheidol; Hughes, L. E., Gwydyr;
Hytch, F. A. L., Llangollen; James, J. E., Goror; Jenkins, H. M., Dovey; Jones, A., Dovey;
Jones, A. A. S., Dovey; Jones, D. M., Ystwyth; Jones, H. G., Dovey; Jones, L., Aeron;
Jones, M., Coed Sarnau and Edw; Jones, O., Aberhiraunt; Jones, T. G. M., Coed y Brenin;
Jones, W. H., Kerry; Kelly, C. L., Lake Vyrnwy; Lane, E. H. W., Radnor;
Little, T. E., Llambod; Lloyd, I., Dovey; Maxwell, A., Gwydyr; Morris, O. I., Gwydyr;
Owen, G. M., Môn; Pierce, G. J., Hafren; Price, G., Ystwyth; Rees, E., Hafren;
Roberts, R. H., Gwydyr; Roberts, R. I., Gwydyr; Roberts, T., Clocaenog;
Ross, J. L., Clocaenog; Royle, J. H., Cynwyd; Shaw, D. L., Ystwyth;
Stockwell, L. A., Tarenig; Storer, E. H., Ceiriog; Tarran, J., Coed Sarnau and Edw;
Tear, D., Dovey; Thomas, R. O. L., Tanat; Thomas, T. W., Dovey;
Vionnee, J. A., Lake Vyrnwy; Wainwright, R., Mathrafal; Waters, R. W., Dyfnant;
Watson, J., Clocaenog; Watson, L. C., Clocaenog; Williams, F., Deudraeth;
Williams, J. D., Clocaenog; Williams, R. J., Dovey; Wood, J. A., Maelor.

ASSISTANT FORESTERS

Ambler, C. R., Coed y Brenin; Beveridge, C. T. W., Tarenig; Brown, R. H., Coed Sarnau; Brown, R. I., Mathrafal; Callan, D., Rheidol; Carter, T. A., Taliesin; Davies, C. C., Radnor; Davies, C. M., Coed y Brenin; Davies, D. D. G., Dovey; Davies, R. D., Dovey; Edwards, B. F., Deudraeth; Evans, I. T., Myherin; Evans, P., Môn; Fletcher, K. W. Radnor; Furnell, K. T., Mathrafal; Goodbody, D., Coed Sarnau; Grayson, J., Dovey; Griffiths, C., Penllyn; Hamilton, J. P., Aeron; Hindle, H. J., Radnor; Hughes, P. M., Deudraeth; Humphreys, H. J., Ystwyth; Isaac, G. M., Ystwyth; Ivison, G. H., Clocaenog; Jones, D. J., Gwydyr; Jones, E. W., Coed y Brenin; Jones, G. W., Rheidol; Jones, J. E., Dovey; Jones, R. T., Glanllyn; Large, A. L., Carno; Legge, D. A., Clocaenog; McLean, A. F., Tarenig; Morris, D. J., Rheidol; Osmond, V. J., Dovey; Pritchard, I. W., Coed y Brenin; Read, J. L., Aeron; Richards, L. G., Halcyn; Roberts, O. J., Kerry; Roberts, R., Maelor; Roberts, T., Dyfnant; Sandy, J. N., Coed y Brenin; Taylor, F. L., Beddgelert; Taylor, W., Coed y Brenin; Waite, E. J. W., Kerry; Webster, J., Elwy; Westlake, M. J. H., Hafren; Wiblin, J. M., Taliesin; Williams, B. H., Dyfnant; Williams, B. L., Aberhiraent; Williams, D. J., Llyn; Williams, J. M., Gwydyr.

FOREMEN

Adams, C., Hafren; Evans, I. J., Ystwyth; Harker, G., Gwydyr; Harker, J., Gwydyr; Lane, F. W., Dovey; Thomas, H., Hafren; Westley, P. C., Carno; Wright, W. A., Dovey.

WALES, SOUTH CONSERVANCY

Block 1, Government Buildings,
St. Agnes Road, Gabalfa,
Cardiff

Telephone: Cardiff 33051

CONSERVATOR: J. Q. Williamson
 DIVISIONAL OFFICERS: Drummond, R. O.; Fitzherbert, J. T. L.
 DISTRICT OFFICERS I: Currie, J. H., Brecon; Jones, E., Llandovery; Pallett, R. E., Carmarthen; Stumbles, R. E.; West, S. J. C., Chepstow; White, J., Neath; Williams, G. O. (Estate); Williams, L. H. (Estate).
 DISTRICT OFFICERS II: Bell, T. I. W., Brecon; Burd, C. J. S., Chepstow; Cram, A. R.; Davis, F. G. (Estate); Harris, E. H. M.; Henderson, J. W., Neath; Marnie, R. J. R., Neath; Miller, A. D., Llandovery; Teasdale, J. B., Carmarthen; Thompson, T. S.; Verel, J. F., Carmarthen.
 CONSERVANCY ENGINEER: Webbe, W. F. G.
 MECHANICAL ENGINEER: Percival, A. S.
 ASSISTANT ENGINEERS: Hoyle, H. N., Neath; Martin, J.; Mills, A., Llandovery.
 CLERKS OF WORKS: Edwards, E. J., Brechfa; Evans, W. J., Llandovery; Godfrey, A. G., Rêsolven (Estate); James, W. B., Crychan; Pennell, J. R., Margam; Price, V. D., Goytre (Estate); Vest, R. E., Wentwood.
 SENIOR EXECUTIVE OFFICER: Bradford, E. H.
 HIGHER EXECUTIVE OFFICER: Morris, T. D. H.

EXECUTIVE OFFICERS

Aitken, D. A.; Blundell, E. D.; Chapman, W. L.; Davies, R. R.; Leaker, R. S.; Tarrant, J. W. A.; Thomas, J. L.

HEAD FORESTERS

Carr, C. P., Crychan; Edwards, L. T., Brechfa; Jenkins, W. T., Ebbw; McNulty, M. E., Tair Onen; Morris, T., Tintern; Smith, N., Coed Morgannwg.

FORESTERS

Baillie, N. S. R., Talybont; Barker, G. J., Coed Morgannwg; Bayliss, L. A., Tintern; Brown, A. H., Tintern; Brown, E., Bannau; Browne, T. N., Bannau; Burnett, R. M., Ebbw; Butter, L., Talybont; Colson, M. H., Coed Morgannwg; Cox, K. E., Ebbw; Eckton, J. A., Coed Morgannwg; Evans, E. O., Cilgwyn; Evans, I. O., Towy; Evans, W. A., Coed Morgannwg; Farrance, D. H., Goytre; Farrelly, P. P., Coed Morgannwg; Gray, J., Llandeilo; Hamilton, A., Coed Morgannwg; Hinds, C. B., St. Gwynno; Hobbs, J. E., Ebbw; Hollowell, E. G., Wentwood; Howson, J., Brechfa; Hughes, B., Teifi; James, D. J. A., Irfon; John, A. G., Penllergaer; Jones, W. E., Crychan; Kerfoot, L. R., Hay; Lewis, D. T., Caeo; Lewis, R. S., Tintern; Lewis, T. H., Mynydd Ddu; Lloyd, J. E. W., Coed Morgannwg; Mackie, C. J., Tair Onen; McMillan, G. H., Brecon; Maddocks, M. R., Crychan; Milson, W. D., Llantrisant; Mitchell, V., Coed y Rhaiadr; Morgan, D. M., Coed Morgannwg; Morgan, W. E., Tair Onen; Nicholls, H., Coed Morgannwg; Powell, N. S., Pembrey; Powell, W. E., Coed Morgannwg; Pyper, A. H. D., Wentwood; Rees, E. G., Gamrhiw; Rees, W. T. O., Coed Caerdydd; Reid, R. J., Gower; Roderick, W. J., Glasfynedd; Saunders, T. G., Monmouth; Slatter, F. A., Slebech; Stevens, W. J., Brechfa; Studley, J. T., Llanddwrfor; Watson, J. D., Giedd; Waygood, G. E., Chepstow; Wheel, P. J., Brechfa; Williams, F. J., Draethen; Williams, W. H., Preseli; Wishart, R. D., Brechfa.

ASSISTANT FORESTERS

Ballard, B. H., Ebbw; Chambers, J. F., Mynydd Ddu; Charlesworth, P., Bannau; Cledwyn-Davies, D. L., Draethen; Davies, G., Pembrey; Davies, M., St. Gwynno; Dean, R., Caeo; Denman, R., Brechfa; Dymond, D. M., Chepstow; England, J. W., Coed Morgannwg; Evans, J. E., St. Gwynno; Fildes, F. G., Wentwood; Fitzgerald, T., Bannau; Fryer, T. G., Talybont; Gifford, H. H., Glasfynedd; Gillett, J., Preseli; Goodhead, A. A., Crychan; Griffiths, D., Coed Morgannwg; Griffiths, H. J., Slebech; Griffiths, W. T., Chepstow; Hall, E. R., Tintern; Hilton, H. C., Brechfa; Hobbs, M., Coed Morgannwg; Holloway, R. J., Slebech; James, T. A. C., Coed Morgannwg; Jenkin, A. M., Tintern; Jones, A. L., Coed Morgannwg; Jones, D., Coed Morgannwg; Jones, J., Towy; Jones, R. S., Tintern; Kenvyn, K., Brecon; Langdon, J. A. T., Brechfa; Lawson, M. D., Towy; Lloyd, D. A., Pembrey; Mackinnon, J. C., Monmouth; Meechan, J., Mynydd Ddu; Morris, G. M., Coed Morgannwg; Needham, A., Goytre; Otto, C. F., Crychan; Phillips, M. W., Coed Morgannwg; Philpotts, K. R. G., Ebbw; Powell, R. W., Coed Morgannwg; Price, R. O., Hay; Reeve, J. A., Gower; Roberts, C. J., Crychan; Roberts, H., Tintern; Sherwood, M. M., Coed Morgannwg; Shuker, K. G., (Tariffing Duties); Taylor, L. S., Glasfynedd; Thomas, R. K., Slebech; Toibin, D., Slebech; Treweeks, E. C., Brechfa; Troughton, R., Brechfa; Walker, P., Coed Morgannwg; Walton, M. J. C., Coed Morgannwg; West, V., Tair Onen; Wilde, C. G., Coed Morgannwg; Williams, S., Crychan; Williams, W. K., Coed Morgannwg.

FOREMEN

Davies, W. R., Caeo; Jones, E. J., Teifi; Jones, I., Coed Morgannwg; Nickels, J. S., Coed Morgannwg; Taylor, W. J., Brecon.

DIRECTORATE OF RESEARCH AND EDUCATION

Office of Director: 25 Savile Row,
London, W.1

Telephone: Regent 0221

DIRECTOR:	James Macdonald
DIVISIONAL OFFICER:	Richards, E. G.
MACHINERY RESEARCH OFFICER:	Shaw, Col. R. G.
DISTRICT OFFICERS I:	Begley, C. D.; Edlin, H. L.
DISTRICT OFFICER II:	Aaron, J. R.
ASSISTANT ENGINEER:	West, R. W. (Alice Holt).
ASSISTANT FORESTER:	Colley, M. A. (Alice Holt).
SENIOR EXECUTIVE OFFICER:	Brooks, Miss A.
EXECUTIVE OFFICERS:	Armstrong, Miss M.; Edwards, E. S.

RESEARCH

Office of Chief Research Officer: Forest Research Station,
Alice Holt Lodge, Wrecclesham, Farnham, Surrey
Telephone: Bentley 2255

Office for Scotland and North England:
Government Building, Bankhead Avenue, Sighthill, Edinburgh, 11
Telephone: Craiglockhart 4010

CHIEF RESEARCH OFFICER:	M. V. Laurie (Conservator).
DIVISIONAL OFFICERS:	Edwards, M. V., Edinburgh; Hummel, F. C.; Peace, T. R.; Wood, R. F.
DISTRICT OFFICERS I:	Bevan, D.; Brown, J. M. B.; Crooke, M.; Cruickshank, H.; Faulkner, R., Edinburgh; Holmes, G. D.; Johnston, D. R.; Mackenzie, A. M., Edinburgh; Matthews, J. D.; Murray, J. S.; Nimmo, M.; Stewart, G. G., Edinburgh.
DISTRICT OFFICERS II:	Aldhous, J. R.; Grayson, A. J.; Henman, D. W., Edinburgh; Jobling, J.; Kitchingman, G. D.; Lines, R., Edinburgh; Locke, G. M. L.; Mitchell, A. F.
SENIOR SCIENTIFIC OFFICERS:	Hinson, W. H.; Jeffers, J. N. R.
SCIENTIFIC OFFICERS:	Howell, R. S., Edinburgh; Taylor, K. D., Tolworth.
EXPERIMENTAL OFFICERS:	Batko, S.; Buszewicz, G. M.
ASSISTANT EXPERIMENTAL OFFICER:	Davies, Miss J.
PRINCIPAL PHOTOGRAPHER:	Anderson, I. A.
PHOTOGRAPHER:	Wood, Miss T. K.
ILLUSTRATOR:	Coram, A. W.
HIGHER EXECUTIVE OFFICER:	Rendle, R.
EXECUTIVE OFFICERS:	Hunter, P., Edinburgh; Nicholas, P. E.; Ridley, C.

HEAD FORESTERS

Farquhar, J., Tulliallan; Gray, W. G., Oxford; Hendrie, R.; Macdonald, A., Fort Augustus; Weatherell, J., Allerston.

FORESTERS

Baker, K. F., Dean; Bartlett, G., Morangie; Brown, R. M.; Campbell, J. A., Edinburgh; Christy, J. M.; Coates, A. E., Exeter; Cooke, A. W., Kennington; Courtier, F. A.; Cousins, D. A.; Dawson, I. J. M., Grizedale; Earl, D. E., Bangor; Fancy, E. E., Wareham; Forbes, G. S., Kielder; Fourt, D. F.; Fraser, D. K., Bush Nursery; Genever, R. W.; Haggett, G. M.; Hall, I. G.; Howe, L. A., Wareham; Howell, E. A.; Howland, B. G., Kennington; Kirkland, R. C.; Leyshon, E., Westonbirt; Macdonald, M. K., Mabie; McLean, C., Bush Nursery; Mair, A. R., Benmore; Moffatt, R., Drumtochty; Ogilvie, J. A., Fort Augustus; Pringle, G., Betws y Coed; Coutts, D. C., Inchnacardoch; Styles, J. H.; Thompson, F., Dean; Thomson, J. H., Newton; Thorne, C. A.; Tugwell, D. G., Thetford; Ure, R. M., Knighton; Waller, A. J.; Waters, W. T., Hinxton; Westall, A. W., Bedgebury; Wilkinson, E. J. D.

ASSISTANT FORESTERS

Armstrong, J., Edinburgh; Bacon, A., Betws y Coed; Baldwin, E., Newton; Balfour, R. B.; Bartle, J., Kielder; Blackmore, I. H., Tulliallan; Blair, W. J., Ae; Booth, T. C., Wykeham; Brown, A. F., Edinburgh; Caird, D. G., Edinburgh; Carter, J.; Collins, R. B.; Coult, D. C., Inchnacardoch; Crofts, E. A., Benmore; Cruickshank, C., Wykeham; Daborn, P. W. W.; Farrimond, G. H., Thetford; Fletcher, E. J.; Gabriel, K. A. S., Wykeham; Gardiner, A. S.; Gardiner, J. B. H.; Gladman, R. S.; Gledhill, H.; Green, A. A., Ae; Gregory, P. A., Knighton; Hoddle, C. R., Exeter; Horn, A. F., Princes Risborough; Johnson, J. M.; Keenleyside, J. C., Morangie; Keir, R. M., Ffosydd Orles; Lewis, R. E. A., Bedgebury; Lightly, A. A., Grizedale; Lock, M., Thetford; Low, J. D.; Macdonald, A. M., Mabie; Maisey, A. J., Princes Risborough; Paterson, J. W., Dean; Pearce, M. L., Monmouth; Phillips, M. T. T., Newton; Rawlinson, A. S., Edinburgh; Reid, A. H., Drumtochty; Rice, D. J., Westonbirt; Simpson, L. M., Aberdeen; Smith, J. B., Edinburgh; Stevens, F. R. W., Kennington; Straiton, J., Edinburgh; Tee, L. A.; Tunks, A. R.; Walker, I.; Webb, M. H.; Webber, C. W., Kennington; Williams, V.; Wray, S. R. P., Inchnacardoch; Young, M. J.; Young, C. W. T.

FOREMEN

Lewis, M. C., Wareham; Lewis, P. G., Dean.

EDUCATION

OFFICE ADDRESS: 25 SAVILE ROW, LONDON, W.1

Telephone: Regent 0221

CHIEF EDUCATION OFFICER: J. H. James (Divisional Officer).
 DISTRICT OFFICERS I: Goodwin, J. F., Dean; Gough, P. C., Benmore; Tulloch, N. W., Faskally.
 DISTRICT OFFICERS II: Dickenson, M. E. S., Dean; Francis, G. J., Gwydyr; Hughes, A. J. G., Gwydyr; MacDonald, R., Benmore.
 HIGHER EXECUTIVE OFFICER: Harper, E. C.
 EXECUTIVE OFFICERS: Chapman, J.; Frost, Miss M. A. E.; Niven, Miss E. B. D.

FORESTERS

Betterton, S. J., Dean; Black, D. F., Faskally; Gale, B., Northerwood; Garrioch, I. M., Faskally; Kemp, R. A. F., Gwydyr; McLaren, A. R., Benmore; Mitchell, R. F., Benmore; Powell, A., Gwydyr; Waddelove, E., Gwydyr.

ASSISTANT FORESTER

Webster, J. T., Dean.

MANAGER, NORTHERWOOD HOUSE

Brown, G.

