

## **SAFE FITTING of BANDTRACKS to HARVESTING MACHINERY**

Recent observations by the Forestry Commission, Forest Operations Training Centre indicate that the current method of fitting bandtracks is potentially an unsafe operation. The current method of fitting bandtracks involves two tensioning chains to connect the tracks and when the chains are under tension the force exerted can bend the chain hooks and in some cases cause chain breakage.

### **Bandtrack Description**

Bandtracks are linked sections of profiled track plates (generally metal) that are fitted over the double wheels of forestry machines. They are used to improve machine flotation, minimise soil damage and provide extra traction, grip and machine stability on difficult terrain. Bandtracks should last between 3000 and 8000 hours depending on the site conditions and, if tyre pressures are maintained, tyre damage is minimised and the tyres should outlast the life of the bandtrack as the tyres are fully protected by the track.

There is a large range of different bandtrack sizes available that are engineered to fit a range of tyre size and tyre lug patterns. Within a specific bandtrack for a specific tyre there are two classifications of bandtrack the 'Lite Link system' tracks and 'Side Link system' tracks.

Both the Lite link and Side link system tracks are available with two sizes of track plate master joining link. The two sizes are 95 mm or 160 mm long with an option for 18 mm or 22 mm diameter connecting pins for both lengths.

### **Matching Bandtracks to Tyres**

It should be noted that a new bandtrack is designed to fit to a new tyre, made by a specific manufacturer and with a specific lug pattern. For example, side link system tracks are not suitable to use with 'Tractor Special' tyres due to the aggressive tractor tread pattern on these tyres, as the track will not fit around the tread profile. However, Lite link system tracks will fit Tractor Special tyres due to the flatter profile of the track plates. When ordering bandtracks it is important to make sure that the track ordered will fit the tread profile of the manufacturer's tyre used on the machine and that the four tyres fitted to a specific bogie are the same.

Tyres for the use of bandtracks should have a non aggressive tread pattern and must be of crossply construction as radial tyres are unsuitable for use with bandtracks.

### **Tyre Pressures**

Tyre manufacturers recommend a minimum and maximum operating pressure for their tyres. It is recommended that the tyre pressure is set at the maximum recommended pressure when using bandtracks, this is due to the extra weight of the bandtracks carried by the tyres e.g. Terra Lite tracks weigh one tonne each side. Low inflation pressures will result in tyre sidewall damage.

### **Bandtrack Tension**

Chain tensioning was initially developed in the early 1980s for side link type tracks where it works reasonably well. However, with the more modern Lite series of tracks, chain tensioning is less effective because it causes the track plates to buckle up and also requires higher tension to achieve the join.

The correct tension for a bandtrack is when there is a 40 mm to 50 mm sag from a horizontal line between the two wheels, in the centre of the top of the bandtrack. Over-tensioning bandtracks will place stress on axles and hub bearings as well as increasing tyre and track wear.

## Plate Removal

After fitting new bandtracks, usually one to two of the track plates need to be removed after the first six weeks of normal use followed by another plate after a further six months due to wear and stretching. The plate should be removed from the middle of the track length as the end joining links are longer than the internal joining links. It should be noted that if a new set of bandtracks were fitted to worn tyres, track plate removal would also be necessary due to the reduced tyre circumference.

## Bandtrack Fitting

The new method developed by Douglas Clark, Clark Engineering uses a ratchet tool and two 'C' shaped staples and is similar in principle to a method devised by Olofsfors in the mid 1990s. The staples are available in two sizes (95 mm or 160 mm long with 18 mm or 22 mm diameter pins) and are shown below in Plate 1.

### Plate 1

#### Track tensioning tool and two sets of staples



1. The forwarder lays out the bandtrack to the rear of the machine with the track plates facing upward.

Laying out the track with the track plates facing upward is a method developed by Jim McDonald, West Argyll Forest District, Forest Enterprise that has a number of advantages over the current method. The main advantage is that the linear space required to fit the track is halved. Other advantages are that the track tends to be located centrally on the tyre, requiring no manual handling. The operation should be undertaken using two people.

2. The forwarder reverses onto the bandtrack, guided by the second person. A rope is attached to the bandtrack by the second person, who then lays the rope over the two bogie wheels and jams it under the second wheel for traction grip (Plate 2).

A disadvantage of this system is that on a hard flat surface such as concrete and with the machine fitted with new tyres the rope can lose tension by slipping between the tyre and the track plates. In this situation the more traditional method of laying out the bandtrack with the track plates face down would be appropriate.

Plate 2

Locating the Rope



3. The forwarder is driven forward, the wheels bite the rope, pulling the track onto the rear wheels.
4. The second person then secures the track ends with two 'C' shaped purpose built staples, which hold the track in place.
5. The forwarder then drives forward until the two C-shaped staples are between the top of the two bogie wheels (Plate 3).

Plate 3

C-shaped staples holding bandtrack in place



6. The forwarder operator or second person then places the track fitting tool on one side of the track (Plate 4), it is tensioned up using a ratchet socket and the C-shaped staple is removed. A long or short joining link is then inserted and the connection bolts are attached and secured. This process is repeated for the other side of the track.

## Plate 4

### Track fitting tool with ratchet socket



### **Safety and Method Considerations**

When fitting the bandtrack the following main safety and method considerations should be noted:

- During the initial positioning of the bandtrack the second person should stand on the opposite side of the machine in case of staple breakage, although it is unlikely that this will occur as the bandtrack is not under tension. The staples are made of mild steel and will bend rather than snap if under tension.
- The joining of the bandtrack is considered safer for the operator as no manual straightening of the bandtrack is required. The staples are designed to hold the track plates in the correct position during tensioning.
- It is recommended that the first staple to be removed should be on the side of the track furthest away from the machine where access is easiest. This ensures that a joining link secures the track before the more difficult inside is connected. Care should be taken when climbing and moving on the bunk during the fitting of the inside of the track, and bolster pins and loader should be moved away if causing an obstruction to safe movement.
- When tensioning up the bandtracks with the purpose built track fitting tool, the risk of the track fitting tool breaking is negligible. Although, the track fitting tool safe working load has not been tested fully, Clark Engineering and Mechanical Engineering Services, Forest Enterprise consider that as the tension is applied gradually it should never be subject to overloading as the 'thread' within the tensioning tool will strip before overloading takes place.
- The new method is very efficient as recent observations indicate that fitting two bandtracks with two operators can take up to 40 minutes. This gives the advantage that bandtracks are more likely to be removed when not required and refitted, rather than leaving them on for all site types.
- The track fitting tool is known to be suitable for a wide range of machines but there may be difficulty with some machines due to bolster pin or chassis design and any difficulties should be relayed to the supplier. The machines found suitable to date include the Valmet 840 forwarder, Ponsse Buffalo forwarder, Timberjack 1410 forwarder and Ponsse HS16 harvester.

## Bandtrack Fitting Method

**Stage 1** The track is laid out with the track paws facing upward

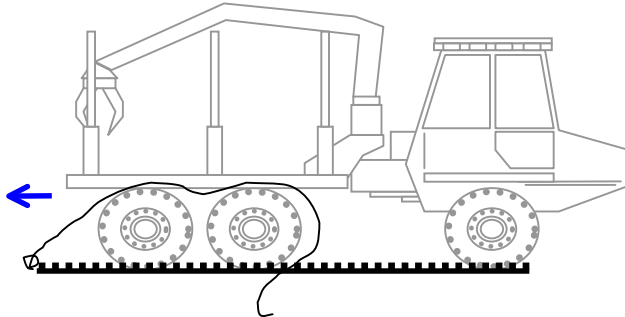

**Stage 3** The track is pulled over to this position where two 'C' staples are placed either side of the track

**Stage 4** The machine is then driven forward to this position with the two staples holding the track tension

**Stage 5** The track fitting tool is placed on one side of the track and a ratchet used to tighten the track, it is then connected and the 'C' staple removed. The process is repeated on the other side

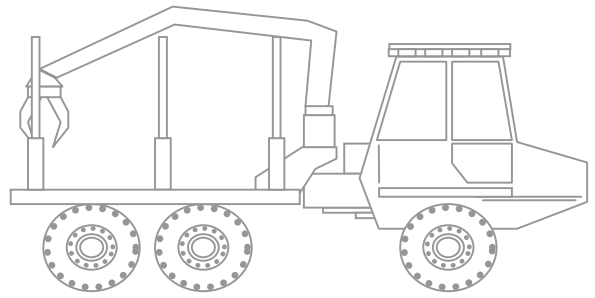

**Stage 2** The operator reverses onto the track. He attaches a rope to one track end, lifts it over the machine wheels and tracks it into second wheel for traction grip

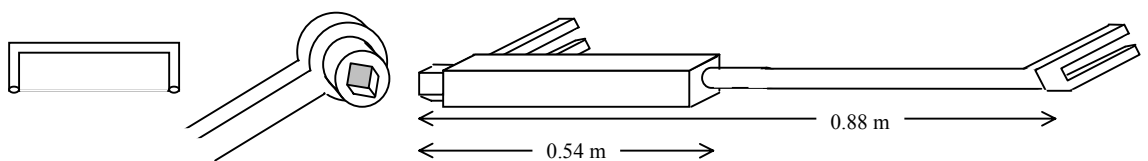
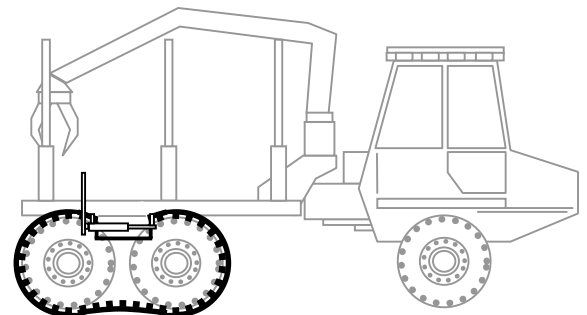
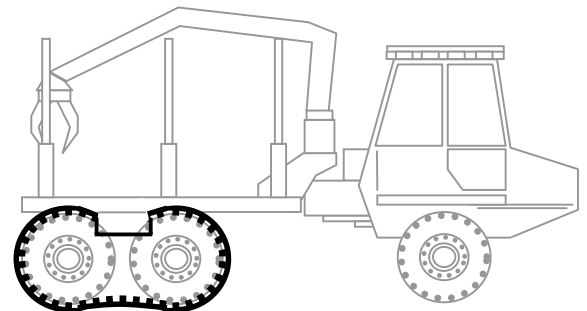
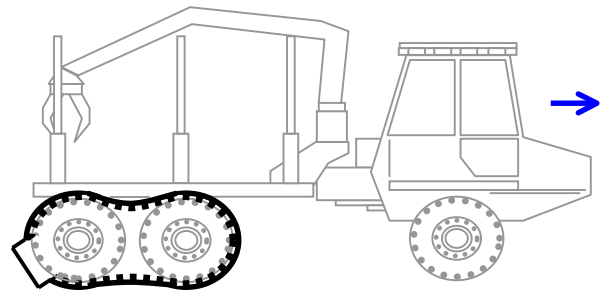

**Supplier and Cost**

The track fitting tool is supplied by William Clark & Son (Parkgate) Ltd, Parkgate, Dumfries. DG1 3NB (Tel 01387 860 241 and e-mail: [info@clark-forest.sol.co.uk](mailto:info@clark-forest.sol.co.uk)) and costs about £150 per unit complete with the ratchet socket.

Steve R Morgan  
Technical Development Branch  
January 2002