



# Forest Research

The Research Agency of the Forestry Commission

## TECHNICAL DEVELOPMENT

### Cableway Extraction

200A/12/05



Colin J Saunders  
Technical Development  
Forest Management Division  
Forest Research

April 2006

Email: [colin.saunders@forestry.gsi.gov.uk](mailto:colin.saunders@forestry.gsi.gov.uk)

Adapted from the original text by A A Rowan  
Forestry Commission Work Study Branch

# Cableway Extraction

200A/12/05

<u>Contents</u>	<u>Page</u>
Introduction	1
Background Information on Cableway Extraction	1
Terrain and Environment	2
Crop Features	3
Site Limitations	3
Cableways as Auxiliary Systems	3
Management Requirements	4
Cableway Extraction Systems	4
Cableway Terminology	4
Highlead Skidding	5
Gravity Skyline Systems	6
Uphill Extraction (winch powered)	6
Downhill Extraction (using gravity)	7
Skyline Systems	7
Cableway Harvesting Systems	8
Shortwood	8
Pole Length	11
Whole Tree Logging	13
Planning and Layout of Racks	13
Survey	13
Rack Layout	14
Rack Specifications	16
Cableway Equipment	16
Winch Units	16
Wire Ropes	17
Rope Specifications	17
Wire Rope Care	18
Splices	20
Rope Connectors	20
Calculation of Drum Capacity	20
Fleet Angle	21
Pulley Diameter	22
Rigging Equipment and Methods	22
Head and Tail Spar Trees	22
Supports	24
Skyline Support Saddles	32
Carriages	33
Chokers	35
Using the Cableway	37
Setting up Procedures	37
Highlead	37

<u>Contents</u>	<u>Page</u>
Skyline	37
Extraction	45
Line Pay-off	46
Communications	48
Hand Signals	48
Radio	49
Mobile Telephone	50
Takedown Procedures	50
Safety	51
Safe Tree Climbing	52
References	53
 <u>Figures</u>	
Cover	
1. Highlead system (with a tree used as a tower) used by a skidder to extract from difficult ground	6
2. Uphill gravity skyline system.	6
3. Downhill gravity skyline system	7
4. Double-drum cableway	8
5. Ideal shortwood stacking	9
6. Good stacking practice	10
7. Poor stacking practice	10
8. Turning poles at roadside with a highlead system	11
9. Fan shaped rack layouts	15
10. Transferring rope from a storage drum onto a winch drum	19
11. Correct use of bulldog grips; U-bolt on tail of the rope	20
12. Fleet Angle	21
13. How to calculate the forces in guy lines at a spar tree	23
14. Types of intermediate support A – M Support, B- Single Pole Support, C A frame, D Single strop	25
15. Skyline anchor trees, right and wrong use of multiple anchor trees	27
16. Diagram and formulae for tail spar anchors	28
17. Anchoring methods	29
18. Offset rigging	31
19. Deflection angle and double support	32
20. Simple skyline carriages	34
21. Chokers and tag lines	36
22. Tail spar fittings	38
23. Position of side pulleys in relation to tower guys and tail spar guy	39
24. Chapelhall skyline system offset when haul-back line goes out on opposite side of rack to the tractor	40
25. Chapelhall skyline system offset when haul-back line goes out on same side of rack to the tractor	41
26. Method to pull out skyline rope with haul-back line	42
27. Diagram of a 5 rack set-up	43
28. Moving the skyline to the next rack using reeving blocks	46
29. Line pay-off methods	46
30. Hand signals for cableway operators	48
31. Rewinding ropes	51

Contents

Page

Tables

1. K Constant related to rope diameter	21
2. Minimum ratios of pulley and rope diameters	22
3. Vertical force of a skyline on a support	24
4. Mid diameter in cm	24
5. Horizontal forces related to stump diameters and soil conditions	28
6. Log dimensions for dead man anchors	31

# Cableway Extraction

## INTRODUCTION

This report describes some of the cableway experience and research gathered over many years by the Forestry Commission (FC). At different times the groups involved were FC Work Study, FR's Technical Development Branch and Technical Development Group, all generically referred to as TD in the following text. Much of the technical detail was won by unique technical investigation in the early days of cableway development. The report was initially produced in 2006 and more information can be included if there is sufficient demand

Training was developed and delivered by the FC Training Branch primarily for FC staff and subsequently by The Sector Skills Council for the Environmental & Land based Sector (LANTRA) and the National Proficiency Training Council (NPTC), for private forest and timber companies.

Whilst a certain amount of information has been published in forestry journals, the results of extensive FC research and development is described in unpublished internal FC reports and training manuals.

Cableway logging extraction systems will continue to be a feature of hill forestry. Thirty years ago many people working in hill forests were familiar with cableway systems but the amount of cableway logging carried out in Britain has declined and few people have direct experience of operating cableways.

The purpose of this report is to ensure the results of research and operator experience are more widely available, particularly to the manager or contractor who may be new to this type of work. Its scope is limited to those techniques which have been used in British conditions.

## BACKGROUND INFORMATION ON CABLEWAY EXTRACTION

Forestry cableways are steel rope-way systems where fully or partially suspended loads are moved by means of moving cables. They can be powered by:

- a stationary winch
- a mobile winch which travels up and down the cableway
- gravity.

Cableways have been used in many parts of the world for the transport of goods, raw materials and sometimes passengers over steep or rough terrain. *Winch and Cable Systems* (Samset 1985) describes the history of cableway development, with particular reference to timber extraction.

In the 1939–45 fellings, tractor-mounted winches were used to extract timber by skidding on ground too difficult for horse extraction. Very few areas of hill forest were in production at that time, and hill ground extraction experience was limited.

Some experimental work was known to have been carried out at the Faskally Forester Training School with simple gravity skylines and light single-drum ground skidding winches. In 1953 the Forestry Commission installed a Swiss 'Wyssen' cableway in Argyll to extract large quantities of timber from difficult ground. The system was effective but labour-intensive, and for economic viability required a larger timber volume per rack set-up than could be found at that time. The French 'Lasso' cableway was also investigated.

During the 1950s tractor extraction took place on firmer, less demanding ground conditions and horses were used on steeper ground. It was understood that there would not be enough horses (and horsemen) to handle the increasing volume of timber on steeper hill ground, so trials began in 1959 with the Isachsen Mk III, a light tractor-mounted double-drum winch made in Norway.

Following a visit by Professor Ivar Samset in 1961, knowledge improved and by 1964 the Isachsen was used extensively in north and west Scotland, Wales and in north England. Used as an unsupported highlead skyline, the Isachsen Mk III had an effective range of 140 m on regular or concave slopes.

This would require a forest road spacing of about 270 m resulting in a relatively high road density in terrain where even low-specification roads were costly. With an economic incentive to extend the range of the Isachsen, a tight skyline system with intermediate supports was developed by the Forestry Commission's Work Study Branch. By the late 1960s extraction distances of 320 m were being achieved, with a maximum range of 400 m with specially modified systems. Later versions were based on the Norwegian Igland 4000 double-drum winch, with a larger drum capacity. These systems were used primarily for thinnings extraction with loads usually under 0.5 m<sup>3</sup>. They depended on the operator's manual skill to achieve the correct balance of line tension to maintain successful results.

In the early 1970s more robust tight skyline systems such as the Jones Igland Alp and the Smith Timbermaster were used, with hydraulic controls and effective ranges of up to 600 m. They could also cope with larger load sizes.

Cableway numbers were at their peak around 1969, when an estimated 157 were in use. In the 1970s greatly improved skidders and forwarders became available. The easier hill terrain, previously extracted by cableways, could now be extracted by tractors or wheel based units.

The higher output and lower costs of wheeled extraction systems encouraged forest managers to push wheeled extraction to the limit. Difficult timber markets in the 1980s forced most forest managers to concentrate production on low-cost tractor logging and thinning ceased in many hill forests. A major limitation is that two men are required to work a cableway extraction system which increases the labour and running costs. The result was a further reduction in the volume of cableway extraction.

In the 1990s there was a revival of interest in cableway systems with the introduction of the larger European systems, such as the Syncrofalke Yarder and the development of tracked excavator based systems. The introduction of these systems was supported by the European Union and local government funding, such as the *Highland and Islands Forestry Initiative*. This revival was short lived as timber prices fell significantly and cableway logging became uneconomical.

Information on worldwide cableway use and design can be found in Professor Ivar Samset's *Winch and Cable Systems* (1985). Design information and calculations can be found in Forestry Commission R&D paper No: 94, *Cableway Design Studies* (Biggs 1973).

## **TERRAIN AND THE ENVIRONMENT**

Cableway systems can be used over all terrain types, with anchorage, support points and extraction distance being the main constraints.

In terms of reduced environmental impact to soils and ground flora, cableway extraction can generally out-perform wheeled, tracked and horse powered systems. This is important where damage cannot be tolerated e.g. sites of Special Scientific Interest (SSSI), restoration sites or sensitive water supply areas and watercourses.

The visual effects of cableway racks in thinned stands are seldom more intrusive than those for other extraction methods.

### **Crop Features**

A significant constraint to cableway logging is the volume extracted related to set up time, which is the time required to lay out the cables and rig the system for extraction.

Low volumes per set up are a serious constraint to viable cableway logging. Recent developments have concentrated on reducing set up time and/or increasing the volume that can be extracted per set up cycle, such as excavator boom based support towers that do not require support guys

### **Site Limitations**

Another limitation is roadside space for stacking and conversion, especially where whole tree or whole pole extraction is taking place. Secondary handling may be required which is an additional expense. This limitation is inherent on steep ground and can also apply to skidder extraction. Availability of stacking space may favour valley floor set-ups, which has to be costed against longer cable runs and the possible need for larger machinery.

Longer runs can give:

- more volume per rack set up.
- increased carriage travel over previously extracted ground.
- reduced carriage speed at in wood end of rack due to reduced winch drum diameters.

Reduction of landing and stacking space can be overcome to some extent by:

- using offset rigging (Savall and Chapelhall winches).
- good organisation of secondary handling and transportation, HGV vehicles with rear-mounted cranes, or auxiliary equipment such as a forwarder or a light grapple-skidder can be used to keep the landing area clear.
- regular timber dispatch.

In cableway operations, the manager must identify:

- suitable stacking points.
- rack layout in relation to landform.
- the availability of spar and support trees especially in thinning operations.

Extreme combinations of steepness and roughness make working within the stand more difficult, particularly at the felling stage. One solution is to transfer delimiting and cross-cutting to the roadside using whole tree extraction to improve safety and reduce working costs.

In clearfell operations, contour felling can be considered to improve the working conditions for the chainsaw operator and concentrate timber for extraction.

## **CABLEWAYS AS AUXILIARY SYSTEMS**

Some coupes which are suitable for wheeled extraction will have areas of difficult ground such as steep banks, gullies and rocky crags. These will often be subject to special management because of their unusual features, but at some stage it will be necessary to fell and extract timber.

Depending upon area and tree size these may be extracted with a:

- specialised cableway, forwarder or excavator mounted for in-wood access.
- double-drum winch skidder in a high-lead mode.
- single-drum winch skidder with a gravity skyline.
- helicopter.

Gravity systems, such as the Savall or Maxwald, have been used and evaluated by TD and have potential in such conditions.

For an area which lies beyond the range of a regular cableway, or in a sensitive landscape area, two-stage extraction may be an alternative to building an expensive road.

An off-road cableway unit could also be considered where the topography allows. The unit is driven into the wood on a well-reconnoitred route to a suitable point from where the outlying area can be extracted. There must be sufficient space for the timber to be stacked prior to its second stage of extraction (usually forwarder) to the road. If two cableways are available, the operation is more efficient, because the loads can be choked on tag lines for easy transfer from one machine to the other.

The first stage could be cableway whole tree extraction to a harvester for processing with secondary shortwood extraction by forwarder.

## **MANAGEMENT REQUIREMENTS**

For successful cableway work, managers and supervisors require a clear understanding of the economics and technical requirements of the equipment and systems. There is difficulty in maintaining and passing on the required knowledge and skill to potential managers, supervisors and operators. Frequent transfers of staff, reducing numbers of systems and experienced operators and comparatively little cableway work results in few opportunities for most cableway logging supervisors to gain the necessary experience. As a result the benefits of efficient cableway logging are often not obtained.

Cableway work requires special skills, a good understanding of the system and an ability to assess and deal with the requirements of each individual situation. Training is essential for efficient and safe cableway work. Even experienced operators benefit from refresher training.

The number of chainsaw operators has reduced with the widespread introduction of mechanised harvesting. Chainsaw operators who can fell large trees in difficult conditions and use the contour felling system are in short supply.

## **CABLEWAY EXTRACTION SYSTEMS**

Cableways can be set up in many ways and many terms are used to describe systems. Some of the main terms are identified for clarification, with further explanation in the text.

### **Cableway Terminology**

Choker	A load rated chain, steel or fibre rope sling which is used to attach the load to the cableway.
Carriage	A frame with pulleys which runs on a skyline, which wholly or partially supports the load during extraction and the choking system during in-wood empty travel.



Highlead	Connected haul-in and haul-back cables used to extract timber without skyline support
Overspooling	The uncontrolled release of rope from a winch drum.
Skyline	Dedicated pre-set tensioned cable which supports the carriage. The skyline can be tensioned by a drum winch or a manual winch. If the skyline tension cannot be changed during operation, it is called a fixed skyline; if tension can be varied, it is known as a live skyline.

The following systems are suitable and have been used in UK forest conditions.

### **Highlead Skidding**

The equipment is less expensive when compared to other systems and is effective over short distances.

The system uses a double-drum winch, usually tractor mounted (Figure 1), with the haul-in and haul-back lines connected and passed around a pulley in wood. The haul-in line is supported on a tree or tower which helps to lift the load from the ground during skidding. The distance over which this lift is effective is about ten times the height of the support on the spar tree. If the haul-back line is braked, some additional lift is obtained.

It is a useful means of extracting small pockets of timber from areas too steep or rough for skidders to operate but where it is not worth bringing in a purpose-built cableway. Any skidder with a double-drum winch can work in high-lead mode, with a suitable spar tree and pulley blocks.

Each drum has a brake and clutch; partially applying the brake to the haul-back drum while the load is being brought in tightens the haul-back line, which lifts the carriage and load. This lift is in addition to the support given by the spar tree or tower fitted to the winch and by any similar lift given by the tail spar. A brake is also partially applied to the haul-in winch to prevent over-spooling during extraction and when sending the carriage back into the wood.

Operating a highlead requires skill, particularly in getting the right balance between clutch and brake. An untrained operator can put more strain on the cables than is necessary and may cause excessive rope wear. With manually operated mechanical controls, the normal operating range of this system is 150 m beyond which the load cannot be lifted over obstructions, and soil disturbance increases. In some conditions a maximum range of 200 m can be achieved on favourable concave slopes. The difficulty in keeping the haul-in and haul-back tensions in balance increase with distance, because the difference in apparent drum speed increases.

Brakes and clutches need to be adjusted correctly and the brakes kept dry. Operation is more difficult when the brakes are wet because they tend to 'grab'. Prolonged and heavy brake application results in heat generation, wasted power and increased wear and tear on machine and ropes.

Creating slack line for the chokerman in wood is an ergonomic constraint with high lead and skyline systems. Without a slack line system, the chokerman has to pull the entire length of haul-in rope. The ability to slacken lines and drop the carriage to the ground can help the chokerman, although he may still find it difficult to pull out sufficient haul-in line.

**Figure 1** Highlead system (with a tree used as a tower) used by a skidder to extract from difficult ground

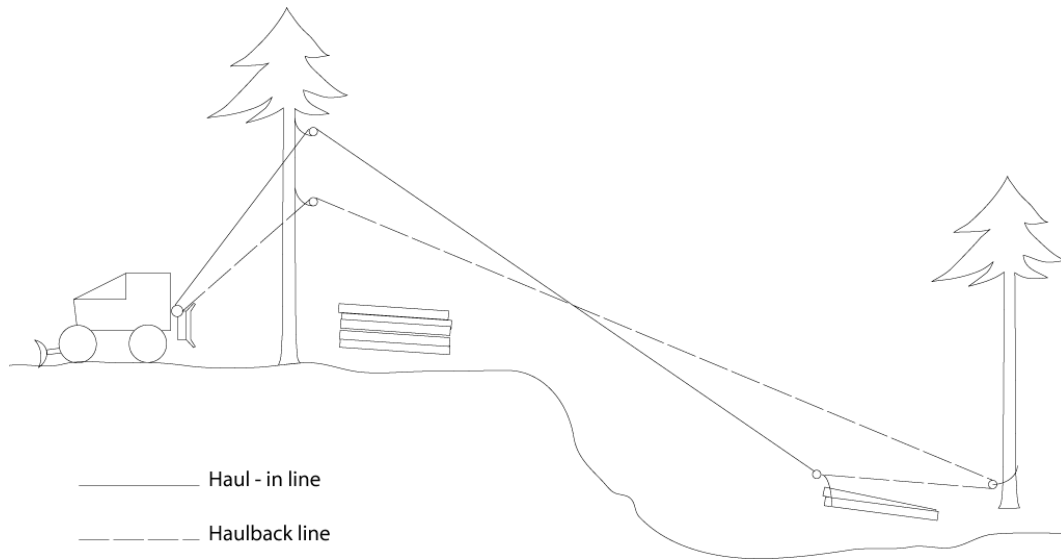

**Gravity Skyline Systems**

Two types are described (Figures 2 and 3) and they are effective where slopes are steeper than 50%. Stacking of timber at roadside is less precise with gravity systems because the carriage is controlled by one cable only. The uphill gravity system is easier to work with and is likely to have more widespread application than the downhill system.

Uphill Extraction (winch powered)

The carriage is attached to the winch and runs downhill (with gravity) into the wood. It is stopped by a command to the winch operator and is restrained by a moveable carriage stop on the skyline. The load is then extracted uphill using the haul-in winch.

**Figure 2** Uphill gravity skyline system.

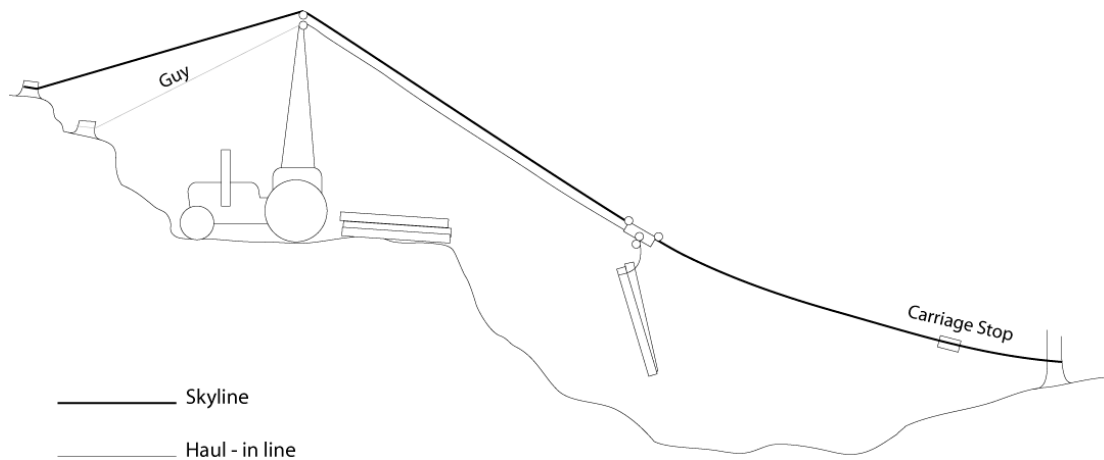

### Downhill extraction (using gravity)

The winch is used to pull the carriage uphill into the wood. The carriage is held at the loading point by a moveable stop while the load is lifted by the winch. The winch brake then controls the speed of descent of the load to the landing. It may be difficult for the chokerman to obtain sufficient slack line to attach the load without the use of a tag line or polypropylene ropes hanging from the carriage.

**Figure 3** Downhill gravity skyline system.

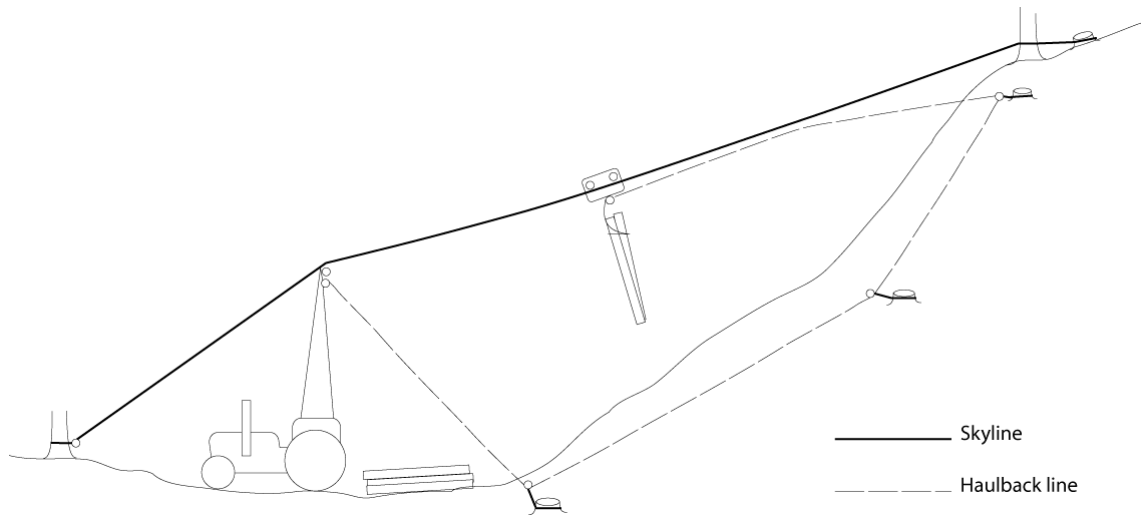

### **Skyline systems**

These use a pre-tensioned skyline in conjunction with a double-drum winch (Figure 4). The skyline can be tensioned by a hand winch or by a powered drum on the winch. If the skyline tension cannot be changed during operation, it is called a fixed skyline; if tension can be varied, it is known as a live skyline. The ability to slacken and lower the live skyline easily is a useful feature for chokerman line payoff and safety. In an emergency the load can be dropped onto the ground with load friction on the ground acting as a brake.

At its simplest, the carriage runs on the skyline cable with tension maintained on the haul-back line while the load is being hauled in, the aim being to raise the front of the load just enough to allow it free passage over obstacles. This method of 'low level skyline' working does not require the load to be fully suspended and so a lighter skyline cable can be used.

Fully or partially suspended skyline systems use a locking carriage which holds the load firmly in place, so avoiding the need to keep a precise balance between haul-in and haul-back drums. A certain amount of braking is required to reduce overspooling. Locking carriages vary in complexity with the more elaborate being heavy and expensive.

Skyline systems are popular because they can be elevated with intermediate supports and can operate over many differing configurations of slope. The operating range is limited by winch drum capacity and machines with ranges of up to 700 m have been used.

**Figure 4** Double-drum cableway

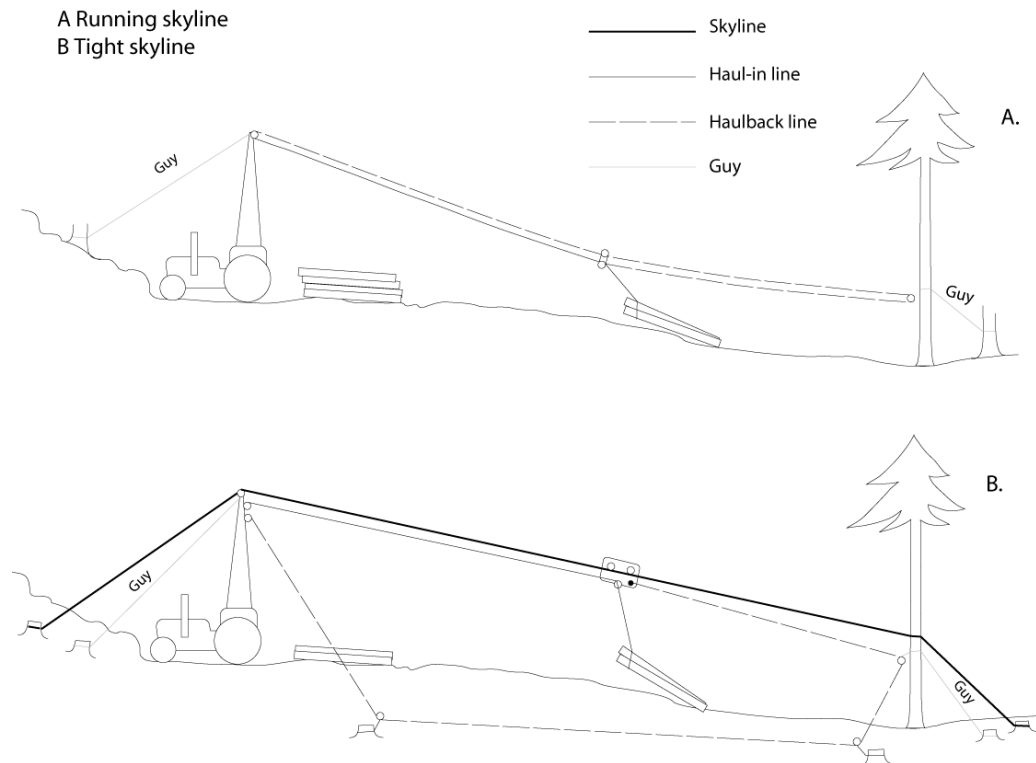

Cableway winches must be able to quickly return the empty carriage to the stand. This can be achieved by using a:

- tractor with a two-speed power take-off.
- gearing system within the winch.
- large diameter haul-back drum.

## **CABLEWAY HARVESTING SYSTEMS**

### **Shortwood**

The shortwood system is understood and widely used in UK forests with forwarder extraction. Cableways can be integrated into this system where forwarders cannot operate. The main features are:

- Felling-conversion and extraction are two separate phases. Straight rack alignment is crucial in thinning operations to reduce damage to standing trees.
- Opportunity to assemble loads of an optimum size, depending upon ergonomic and manual handling constraints.
- The system can be applied to final felling and thinning.
- All waste material is left in the stand and does not present problems of disposal.
- Roadside space can be more efficiently used for stacking converted material.
- It is not well suited to more than two products.

The tree is felled and crosscut at stump into sawlog(s) and small roundwood, usually 2 or 3 m lengths. The feller then assembles smallwood to form stacks (Figure 5), moving lighter pieces to the heavier pieces.

The stacked timber should be supported on a cross bearer for easy chokering. If the bearer is too thin, the load may sink into the brush, and have to be rebuilt at the time of extraction. Sawlogs are convenient bearers. Stacks of smallwood should never be assembled on top of one another; when the top stack is moved, it invariably scatters the one beneath. Boulders, banks or drains are useful substitutes for bearers.

A specialised form of shortwood presentation known as contour felling can be used in clearfells. Bearer trees felled across the contour are used to support the tree during snedding and assist the movement of the unconverted pole length with gravity to the timber zone. Pole length material slides down the bearers (after snedding and release from the stump) where it is restrained by unfelled stopper trees in the timber zone. The premarked tree is then converted and the stopper trees felled when no longer required. Contour felling creates concentrated bands of timber. Initial break-in when extracting can be difficult.

**Figure 5** Ideal shortwood stacking

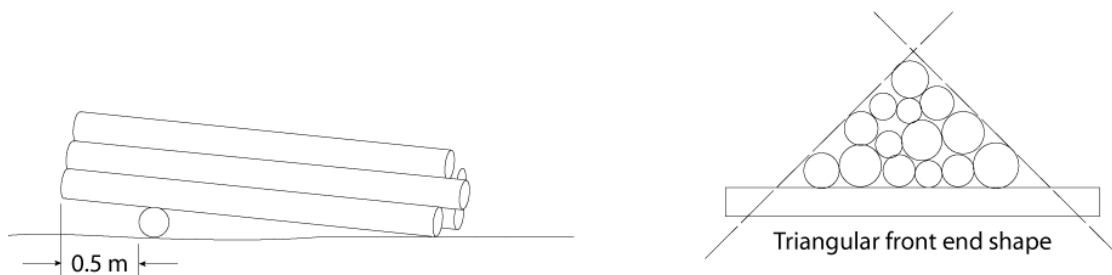

The stack should have:

- a large bearer to keep stack front off ground.
- front ends of pieces stacked flush.
- a bearer about 0.5 m from front of stack.
- a triangular end shape.

In thinnings the load must be aligned for easy passage to the rack (Figure 6) and should point slightly uphill; this gives good directional control during side-haul.

Shortwood stacks prepared from trees felled in the rack should be placed at the rack edge, between rack side trees, with the bundles projecting about 0.6 m into the rack. On steep ground the stacks can lie against the top side of a rackside tree.

If loads are arranged this way there is much less chance of trapping the haul-back line on a stack and scattering the smallwood, which should never be in the middle of the rack (Figure 7). The chokerman can pre-choker these rackside loads in safety while the cableway is working. Loads should not lie behind the tail spar tree.

**Figure 6** Good stacking practice

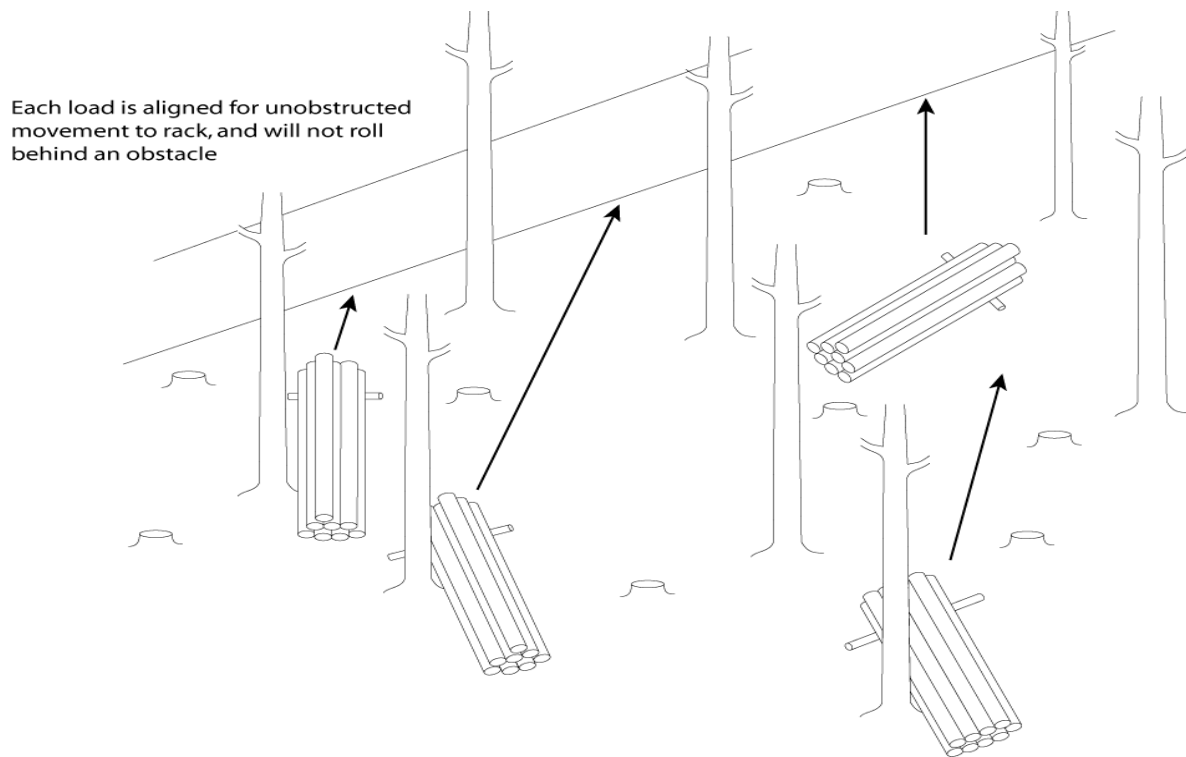

**Figure 7** Poor stacking practice

- A Load underneath will scatter when load on top is moved  
Top load is badly aligned and bearer is inadequate
- B No bearer and way out obstructed by large stump
- C Bearer too near front of load which is badly aligned and obstructed by two trees

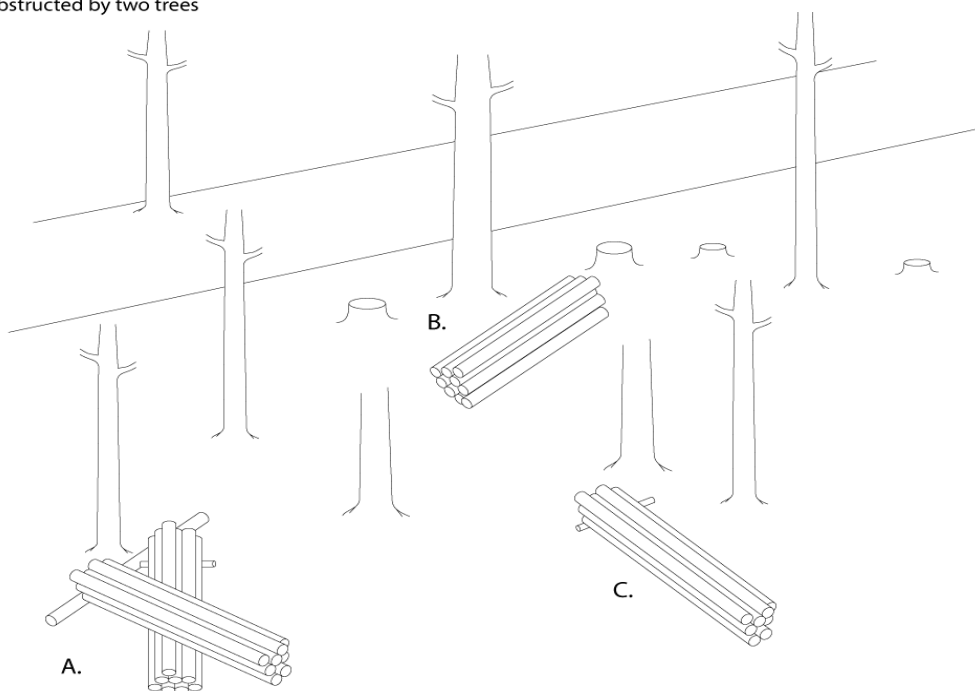

Load position in final fellings has to be considered because there are no trees to obstruct side hauling. The brush mat can cover stumps which can be significant obstacles to extraction.

In thinnings shortwood stacks should have an average size of 0.30 m<sup>3</sup> increasing to 0.40 m<sup>3</sup> for clearfells, although load size can depend on the individual piece size and straightness of the produce.

Good produce presentation is essential. Poor presentation reduces output and the crew become frustrated and demoralised. All produce to be extracted should be clear of brush and easily seen. Organised felling with produce clear of rackways will give higher extraction outputs.

### **Pole Length**

Pole length working is an important system for cableways in Britain. The following points should be considered:

- The three phases of felling, extraction and conversion require good supervision for integrated working.
- Good directional felling is essential.
- Poles and whole trees are easier to find than shortwood pieces, especially on broken ground.
- Poles should be angled to the rack in the direction of extraction as it can be difficult to turn big poles in the rack during extraction.
- Poles should be left at the landing area after extraction or pulled away with a secondary machine. No conversion should take place at the landing area adjacent to the cableway when the winch is in operation.
- It can be difficult to pre-assemble adequate loads in selective first thinnings or with trees less than 0.1 m<sup>3</sup> average size.
- Thinnings have to be designed so that poles and whole trees can be moved into the rack easily.
- Damage to standing trees is difficult to avoid, especially in later thinnings.
- Roadside conversion favours flexible conversion regimes and accurate crosscutting, particularly of high-value or long-length products.
- There is a greater opportunity to cut more products, depending upon roadside stacking and secondary handling facilities.
- The system needs handling, cross-cutting and stacking space at roadside, especially if poles have to be turned
- The storage of poles or converted products requires large stacking areas. Ideally extraction, conversion and removal by lorry should be co-ordinated (hot logging) to keep landings clear.

When thinning, the felling should present the stems at 30° and 40° to the rack. This is easier to achieve in pattern thinnings, e.g. chevrons or herring-bone, where the racks can be aligned at the correct angle. Extraction can be tip or butt first, although butt first increases the weight of suspended loads. Large trees from late thinning and final felling may be felled towards the rack (reducing side-haul distance) and extracted tip first.

Presentation at final felling should present poles that are free of green brash with tips or butts accessible for chokering. Systems such as strip felling will be suitable. Sprags should be left for tip first extraction.

Poles can also be turned (Figure 8) by placing a pole at an angle across the mouth of the rack with one end raised by resting it in a tree.

**Figure 8** Turning poles at roadside with a highlead system

1. The load is dropped on the cross-pole with its point of balance between the cross-pole and the stack
2. Slacken the haul-back line, let load slide sideways
3. Wind in the haul-back, load drops onto stack
4. Run carriage back, stop, haul-in, load drops onto stack

Using a tight skyline, follow steps 1, 2, and 4.

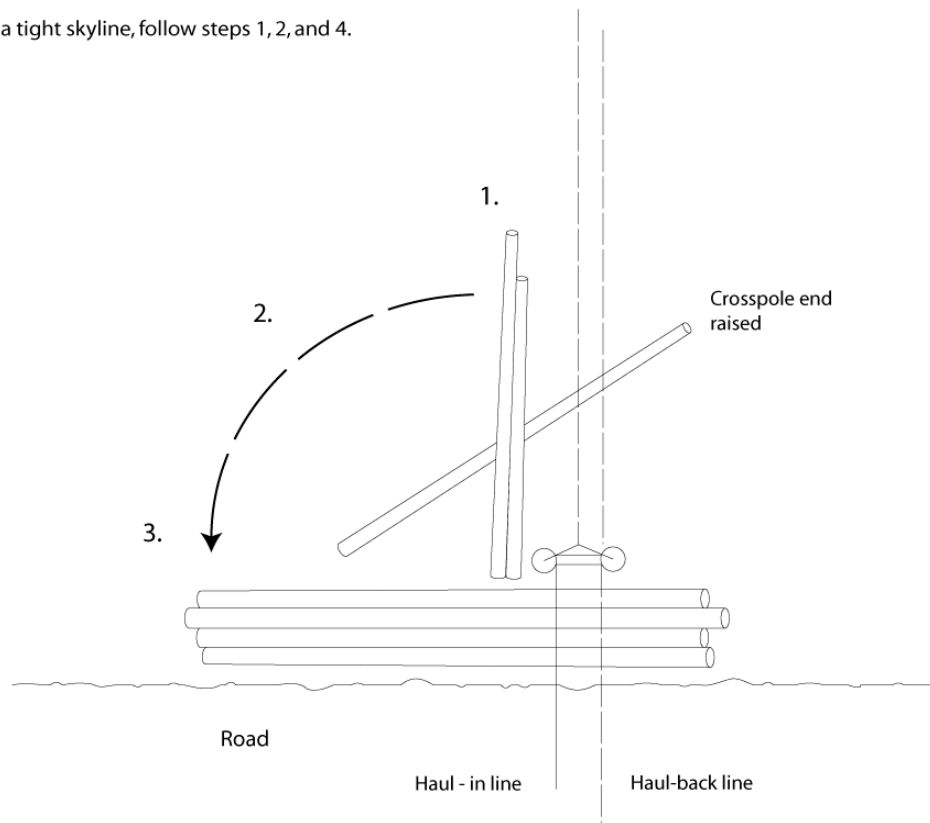

Turning poles takes skill and time, and production can drop by up to 30%. The problems of stacking space are exacerbated with pole length extraction, and any secondary extraction increases costs. Large stacks of poles can be a safety hazard.

Partial tree conversion is a half-way house between shortwood and pole length, in which the tree is felled at stump, severing the sawlog element from the small roundwood.

- Assembling correct load sizes may not be easy in thinning.
- Damage to standing trees is easier to avoid than with whole poles.
- Roadside space has to be sufficient to stack two long products.



In each of the systems described above it is important that tops and dead trees are cut into lengths no longer than 2.0 m. This is essential to allow easy movement of brush, loads and improve management operations after final felling.

### **Whole Tree Logging**

The use of whole tree logging has increased but a number of points need to be considered:

- Felling output per man is high. This is important where skilled labour is scarce.
- It is a more ergonomic system on terrain where chainsaw delimiting and cross-cutting can be difficult.
- Felling can be carried out by the chokerman on clearfells.
- The system can be used in windthrown stands.
- The system requires good management. Correct selection of landings is vital, and each site has to be individually assessed. The right balance must be maintained between felling, extraction, processing (particularly if the processor serves two or more cableways) and timely despatch of produce.
- A processing machine and roadside space for it to work is required. This may involve the construction of temporary landings.
- Extraction and processing should be combined if possible. Accumulation of large heaps of whole trees can be difficult, even where space is available. The processor must be capable of disentangling stems with branches.
- Load sizes in timber terms may be reduced due to branch weight.
- Brush accumulation and leachate from brush must be managed. Roadside residues are reduced if the feller cuts tops off in wood.
- Studies in UK conditions in first thinnings, suggest that whole tree working with smaller tree sizes is not viable.
- Extraction is usually butt first, i.e. felling is uphill for downhill extraction.

### **PLANNING AND LAYOUT OF RACKS**

Well sited and laid out racks are essential for safe and efficient cableway working. Rack layout is not easy, especially at the first thinning stage. There are penalties of increased costs and reduced output in this and subsequent thinnings, if poorly planned.

#### **Survey**

The first stage is a physical survey of the area which should always be carried out prior to the felling operation in thinning and clearfell operations. It should be carried out by a supervisor with sound knowledge of the equipment and working methods. Factors to be considered are:

- Roadside stacking space. This is often the limiting factor. Three metre length material requires a 2.5 m frontage for every 10 m<sup>3</sup> (including air spaces) stacked to breast height. Timber should not lie further than 5 m from the edge of the forest road, for subsequent loading onto timber wagons. The rack should terminate in the best available natural space. It may also be necessary to :
  - create additional space by felling roadside trees and forming new stacking areas
  - use road bends as rack exit points.
  - offset the cableway to allow stacking on the road surface.
  - turn poles to lie parallel to the road.
  - have another machine available to move timber away from the unloading point.
  - organise removal of timber by HGV to reduce stocks.
- The minimum volume required to justify set-up costs over the distances to be extracted. This influences decisions on frequency and type of thinning, so that adequate volumes can be obtained. The volume carried by each rack depends on the area served by it, hence the rack spacing. Avoid racks converging or crossing. Areas of 'dead ground' may be so extensive that volumes are too small to justify a thinning operation.
- Conditions within the stand. Delayed first thinnings may be so difficult to take down that only a 'mechanical' herring-bone pattern thinning is practicable.
- Location of obstacles such as cliff faces. These need decisions on whether racks should be sited to avoid adverse ground conditions or whether appropriate supports can be provided. Use aerial photographs, if available, to identify likely obstacles.
- Availability of spar, anchor and support trees. This requires ground survey, helped by aerial photographs.

### **Rack Layout**

Ideally rack layout should be done before the first thinning and it is essential to plan rack layout to enable the cableway to operate at maximum efficiency.

Rack layout should follow this sequence:

- Choose the pattern and rack spacing to be adopted, within the limitations of roadside stacking space. A rectangular layout of parallel racks is the most efficient. On broken ground, select the location of major racks first - those with the best concave profile - then fill in with shorter ones. Try to avoid many short racks with correspondingly high set-up times; this is particularly important for tight skyline working. Do not cross racks.
- Lack of stacking space is sometimes overcome by a fan-shaped layout (Figure 9), of several racks converging at roadside. This may be the only solution, but the layout is inefficient and will increase the average extraction distance by up to 40%.

**Figure 9** Fan shaped rack layouts

Rack length =  $x$

Average extraction distance:  $a \frac{2}{3} x$   
 $b \frac{1}{3} x$

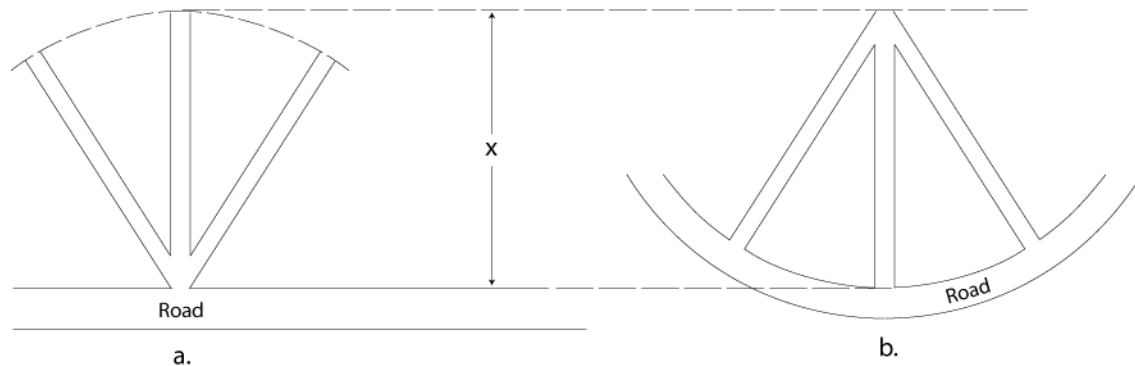

- Set out the racks, marking rackside trees. Fluorescent plastic tape is best for this, as corrections are easier than when marking with paint or worse still, blazing stems with a slasher. Racks must be straight and set out by using one of the following methods:
  - By eye, with the help of ranging rods (preferably fluorescent). Trees in the line of vision make it necessary to offset from the centre line; this causes unacceptable deviations, especially on long racks.
  - Using a compass. Again, offsetting errors can occur.
  - Using coloured racking lights. These are mounted on ranging rods with a horizontal cross-member at the top to which are attached three battery-operated lights of different colours, one central and one on each side. Work from the central light initially, and when vision is obscured by the intervening trees the side lights are used to give two other parallel lines. Racks can be laid out very accurately by this method.
  - By felling the rack. The feller is given the correct direction initially and can keep the rack straight in line with ranging rods, set up at roadside to start with. This method is cheap but does not allow any adjustment of the alignment e.g. to avoid unforeseen obstacles.
- Select spar, anchor and any necessary support trees for this and future operations. Ideally this should be done before the first thinning is marked. If the stand has been thinned previously it is more difficult to find suitable trees. Look for sturdy, well-rooted trees of adequate height which will resist side-haul strains and mark them clearly with paint so that they are not inadvertently removed in subsequent fellings. This selection has to be made when marking the rack on the ground. The tail spar tree should be at least 20 m in from the outside edge of the stand.
- Low stressed cableway systems do not require calculation of support forces if the load is not to be fully suspended. Support points on the rack can be selected by an experienced crew if they have been briefed on the size of spar, support and anchor trees required. When partially or fully-locking carriages are used, the load will be fully suspended on concave profiles, and the system must be designed to cope with greater loads.
- If the trees are stunted and small at the tail spar and support points, artificial supports may be required.
- Mark the centre line of the rack on both sides of the road at the rack mouth. This assists with lining up the tractor and rigging.

## Rack Specifications

Rack width in thinnings	3.0 - 3.5 metres
Profile	Highlead: concave to regular, but not convex unless supported. Skyline: will require support at convex points.
Alignment	Must be straight.
Rack spacing	Selective thinning and } 20 - 25 metres Pattern thinning / shortwood }  Pattern thinning (chevron or } herring-bone) with pole } 35 - 40 metres length extraction }
Final fellings	Minimum rack width 20 m, preferably wider up to the limit of trouble-free side hauling.
Side slope	Avoid if possible, can cause damage to trees on the lower side of the rack.
Relative direction	Keep parallel if possible: no criss-crossing.
Stacking space	Must be adequate.

## CABLEWAY EQUIPMENT

### Winch units

Cableways in Britain are based on tracked excavators, forwarders, lorries and agricultural tractors with winches and tower, mounted directly on the prime mover or on trailers. Choice of machine will depend on individual requirements, determined by access, crop and terrain.

The typical tractor-based units used 45 – 65 bhp models. Lighter tractors are adequate for cableways used on short ranges and load sizes up to a tonne. Larger engine size gives the power necessary for heavier loads and long range work.

Tracked excavator units (usually 20 tonnes plus) can dig access tracks and usually have a tower fixed to the boom which can be supported by using the bucket as a ground anchor in an excavated pit. Forwarder based units generally have improved traction and ground clearance compared to tractor based units.

The principal manufacturers of cableway systems (as distinct from winches) in this country were James Jones & Sons of Larbert, G.R. Smith, and the FC Mechanical Engineering Division.

Most of the equipment in use is either new or second-hand and modified for use with a prime mover such as an excavator based machine. Excavator based machines are currently being supplied by A & B Services, Ltd, Killin, Scotland and BTP (UK) Ltd, Llanfair Caereinion, Wales. There are UK agents for cableway carriages and European agents can be contacted for European cableway systems.

Potential users of modified new and second-hand equipment should ensure that their cableways and winches do conform to new EU legislation such as:

- Machinery Directive 98/37/EC concerning modifications, conditions and spares.
- Provision and Use of Work Equipment Regulations 1998, (PUWER).
- Lifting Operations and Lifting Equipment Regulations 1998 (LOLER).

In addition:

- All ropes should meet cableway manufacturer's specification and be in good condition. Refer to guidance in TDB Technical Note 8/94 *Cableway Rope Discard Criteria*.
- Winches, pulley blocks, carriages, beams, towers and associated components should be clearly marked with a maximum safe working load. The system or components should not be loaded above these limits. The system safe working load must be clearly marked and understood.
- Diameters of pulley blocks and depth of groove should be adequate. Specification details are given below.
- All safety hooks should have effective safety latches to prevent them being accidentally unhooked. This does not apply to choker hooks, where easy fastening and unfastening is important, or to line connectors.
- Chains should only be joined by a screw shackle or a master link of the same working load (or greater) as that of the chain being joined.
- Chains, rings, links, hooks, shackles, swivels or eyebolts should not be altered or repaired by welding.

Any components which do not meet the above criteria should be replaced by items of the correct specification.

Ensure that maintenance equipment is available, as specified by the tractor and cableway manufacturers.

### **Wire ropes**

Ropes are used in abrasive conditions and receive variable loading conditions. It is essential to use the correct type and size of rope for reasons of safety and economy. Operating costs can increase if they are wrongly specified, used carelessly or not maintained correctly. Cableway manufacturers supply schedules for ropes appropriate to their machines, which should be followed.

Ropes must be securely fastened to winding drums. At least three full turns must remain on the drums at all times.

### Rope specifications

These vary according to the requirements of the particular system. The specification should cover:

- *Length*: This is governed by the size of the winch drums and the maximum length that can be wound on. Note that haul-back lines can be longer than the drum capacity, because additional lengths can be added by splicing and/or by the use of suitable connectors.

- *Diameter*: This, with other factors, determines rope strength. The haul-in line takes a greater strain than the haul-back, and a larger diameter is often used. If the two lines are the same diameter, a haul-in line which has become shortened by wear but is still serviceable, can be spliced into a haul-back line to extend it or replace a worn part.
- *Finish*: Usually ungalvanised with galvanising unnecessary on a working rope that is oiled frequently. Galvanising may reduce its strength.
- *Tensile strength*: Usually 180 to 200 kgf/mm<sup>2</sup>.
- *Construction*: After strength the main requirements are flexibility and resistance to abrasion. Construction is defined by number of strands and the number of wires per strand. See examples below:

A 6 x 19 rope consists of 6 strands each made up of 19 wires. The latter are arranged as 12 wires surrounding 6 wires; which surround 1 central 'king' wire; this arrangement is expressed as 12/6/1. A 6 x 19F rope is similar, with the inclusion of 6 small-diameter filler wires between the 6-wire and 12-wire layers. A 6 x 19 construction gives abrasion resistance with some loss of flexibility, and such ropes are used for cableways (haul-in, haul-back and skyline) and support guys.

A 6 x 36 construction gives good flexibility with poor abrasion resistance; such ropes are used for guys. The strand is made up of layers of wires, alternately large and small. The 36 wires consist of an inner layer of 7 wires around the king wire, a middle layer of 14 wires (7 large and 7 small) and an outer layer of 14 wires. This is specified as '14/7 and 7/7/1'.

- *Core*: This can be hemp fibre, nylon or wire. A fibre core aids flexibility and retains oil to lubricate and preserve the rope. Inner wire rope core (IWRC) ropes have cores of small diameter rope having 6 strands around a central core. Wire strand main core (WSMC) ropes have as a core a strand of wire exactly like the other strands. IWRC and WSMC ropes are less flexible but are better able to resist the crushing effect which occurs when the rope does not spool properly.
- *Lay*: This refers to the direction in which the wires are twisted in the strands and the direction the strands are twisted together. In ordinary lay the wires are twisted together clockwise and the strands anti-clockwise. In Lang's lay both directions are the same; this has the advantage that it is more flexible than ordinary lay, but has a greater tendency to kink and untwist. Right hand ordinary lay is more satisfactory for cableway work.

### **Wire rope care**

Wire rope is expensive and prone to accelerated wear if misused. Ropes should be replaced when visual inspection shows that the original diameter of the outside individual wires has been reduced by one-third. Further information can be found in Technical Development Branch Technical Note 8/94 *Cableway Rope Discard Criteria*.

The initial winding of a new rope onto the drum is important (Figure 10). If wound on incorrectly it can twist, coil and unwind during and after use. The winding on should follow the 'twist' and lay of the rope.

Careless winding of a new rope can cause damage. The pay-off drum has to be braked to give good spooling tension.

**Figure 10** Transferring rope from a storage drum onto a winch drum

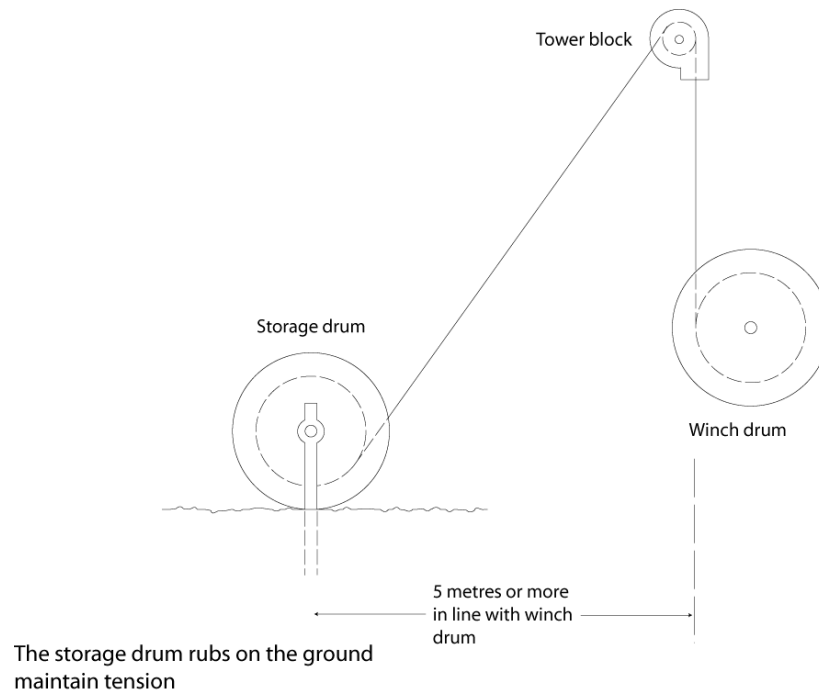

Ropes can be damaged when slack turns develop on the winch drums, particularly when running out the haul-in line. Slight braking applied to the drums prevents over-spooling.

Despite careful working, there is a tendency for a few coils of rope on the drum to work loose, just beyond the length being used. The rope will be damaged if these are not tightened. This can be done by hand if only a few coils are slack; otherwise a rewind by machine is required. If the tail block is at least half the length of the rope away from the winch, the full length of the ropes can be run out and re-wound under tension.

Snagging or mis-run of the rope at the carriage results in rope damage. Both chokerman and winch operator must watch out for any sign or sound of the ropes catching on any part of the equipment, not running true in the pulleys, and for any pulley or guide block not running freely. If anything is wrong, stop and take corrective action immediately.

Ropes should be frequently lubricated whilst on the drum, using the manufacturer's recommended oil. Old engine sump oil must not be used because the lubricating properties are degraded and it also contains acidic contaminants and metal deposits that act as a grinding paste. When rope is to be stored it should be passed through a container of oil before storage.

If fibre cored ropes are not soaked with oil they can absorb water and rust internally while in store. Well lubricated ropes will last up to three times longer than those which have become dry and are much easier to maintain, splice and handle.

Most breaks occur in the haul-in lines. Skyline rope failures are uncommon. Safety requirements dictate that broken or damaged ropes are repaired at once. Anchor guy ropes are the exception: these must be replaced, not repaired.

## Splices

These can be used to repair breaks and use short lengths of unworn rope. Individual broken wires do not seriously affect the strength of the rope, although they make handling difficult and protective gloves must always be worn. A broken strand must be repaired, otherwise a complete breakage can occur next time the rope is under load.

The haul-in and haul-back lines suffer impact and abrasion damage at the choker end by chafing between the load and the ground surface. Where repairs are made by cutting off the damaged section, the haul-in line will eventually become too short. Using tag lines can overcome this problem.

Repairs to the middle of a rope require a long splice which is approximately 1 m long for every millimetre of rope diameter. Operators have to be trained repair ropes with a long splice and it can take 2 men up to 4 hours to carry out this task. Various publications on rope splicing are available from rope manufacturers. A long splice reduces the strength of a rope by approximately 10%. Skyline cables can be spliced safely with a long splice, but it should be inspected weekly.

Guidance on rope splices is given in AFAG Guide 504 *Extraction by cable crane*.

## Rope Connectors

Bulldog grips can be used on cableway guys. They should be fitted as shown in Figure 11, with the bridge on the working part of the rope and the U-bolt on the tail or dead end of the rope. They should not be used on tag lines; use an eye splice instead.

Lengths of running cable can be joined by special coupling links designed to pass freely over pulleys. It is not recommended to have these on the portion of rope that winds onto the winch drum, because the rope coils may become uneven.

**Figure 11** Correct use of Bulldog grips; U-bolt on tail of the rope

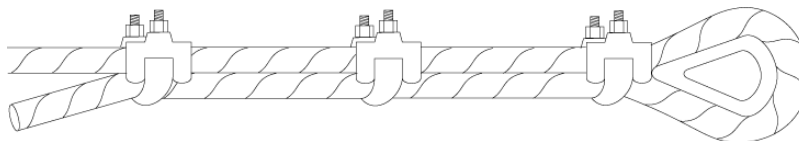

## **Calculation of Drum Capacity**

If the capacity of a drum is not known it may be calculated by the following formula:

$$L = (A + B) \times A \times C \times K$$

where L = Length of rope in metres  
A = Flange depth in centimetres  
B = Empty drum diameter in centimetres  
C = Width between flanges in centimetres  
K = constant, related to rope diameter

Guidance is given in Table 1.



**Table 1** K Constant related to rope diameter

Rope Diameter (mm)	6	8	9	10	11	12	13	14	15	16
K (constant)	0.0698	0.0393	0.0313	0.0251	0.0208	0.0175	0.0147	0.0128	0.0112	0.0098

This formula calculates a rope length which is 80% of the theoretical capacity, which gives adequate flange space above the rope on a full drum. It assumes that the spooling is good.

There are limits to the drum capacities of simple cableways. Large drum diameters will result in large differences in pulling power and spooling speed between full and empty drums, while wider drums can give rise to spooling problems. Seek the advice of the manufacturer or winch supplier before changing or modifying drums. A false drum centre can be used to increase rope 'pick up' speed when smaller diameter ropes and or shorter rope lengths are used on higher capacity winch drums.

### Fleet Angle

The rope must be guided onto the winch or storage drum through the correct 'fleet angle'. As the rope is wound on, it travels through the fleet angle from one side of the drum to the other (Figure 12). If this angle is too large ( $>1.5^{\circ}$ - $2.0^{\circ}$ ), spooling becomes uneven. Guide blocks on the cableway tower are positioned so that the centre line between the guide block and the winch is perpendicular to the winch drum axis. The distance between the guide block and the winch drum should be at least twenty times the width of the drum. This ensures that the maximum fleet angle is less than  $1.5^{\circ}$  to  $2^{\circ}$ .

The correct fleet angle must be maintained when:

- spooling a rope off a storage drum onto a winch or vice versa.
- a double-drum winch tractor is used in cableway mode without a tower, perhaps using a spar tree as a substitute for a tower.

**Figure 12** Fleet angle (Samset 1985)

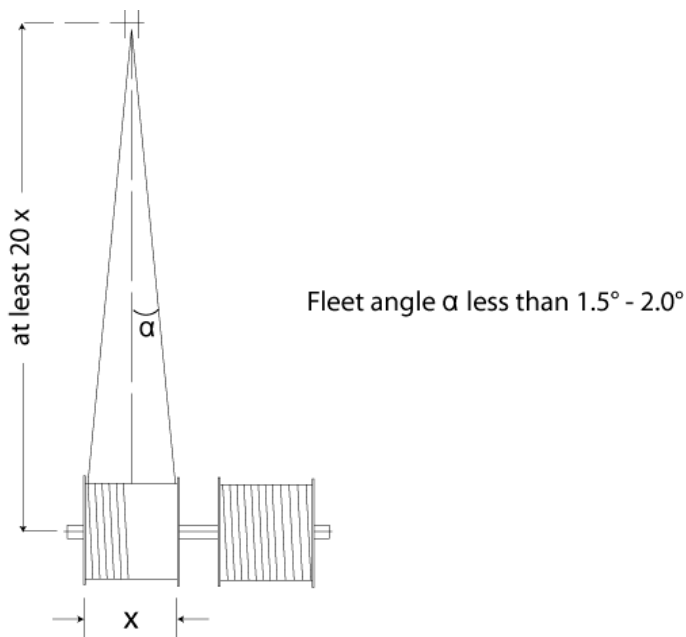

The fleet angle should be less than  $1.5^{\circ} - 2^{\circ}$  to obtain satisfactory spooling of rope onto winch drum.

### **Pulley diameter**

A rope passing over a drum or pulley is subject to differential tension, with tension increased in the outer wires of the rope. The wires also move against each other, hence the need for lubrication. Pulley diameters should be large enough (Table 2) so that the rope is not subjected to excessive stresses. The rope must have maximum contact with the pulley for full support when running. If there is insufficient support, the rope can 'spread' or flatten.

**Table 2** Minimum ratios of pulley and rope diameters

Rope Construction and Make	Minimum ratio: Diameter of pulley to diameter of rope
6 x 7	42
6 x 12	26
6 x 19	26
6 x 19 Seale	32
6 x 24 Seale	26
6 x 19 Filler	26
6 x 31 Warrington	26
6 x 36 Warrington	21
6 x 41 Warrington	28

The pulley groove must also have sufficient radius to allow splices and rope coupling devices to pass easily. Cableway work requires that the sides should form an angle of  $120^{\circ}$ , and the rounded bottom of the groove should have a radius 10% greater than the radius of the rope. This contrasts with most industrial usage, where the depth of the groove equals rope diameter.

## **RIGGING EQUIPMENT AND METHODS**

### **Head and tail spar trees**

Spar trees are used to raise the cables, to partially or completely suspend the load off the ground. Tail spars are commonly used, although the profile of the slope can make them unnecessary. Extraction can be carried out effectively with the tailblock rigged at ground level. A tailblock at ground level needs an anchor tree or trees.

Most cableways use a steel tower at the winch, but a head spar tree may be used, usually when the winch is offset, especially skidder highlead systems.

A skyline rope must be under tension for the load to be supported. An unladen tensioned skyline takes on a natural curve caused by gravity between its fixed points. Spars and support trees deflect the skyline from this natural shape and are subject to forces as they take their share of the weight of rope and load during extraction.

Spar trees are braced in position by guy lines. A tight skyline may act as a guy line, and if it changes direction at the spar tree a guy is necessary to counteract the sideways pressure on the tree. Guyline(s) also exert a downward force on the spar tree, which must be sturdy enough to resist these forces. All anchor ropes should oppose the forces applied to them and spar trees should be subject to a force which is transmitted directly down the tree (Figure 13). The spar tree can be pulled over if the force is at an angle to the tree.

**Figure 13** How to calculate the forces in guy lines at a spar tree (Samset 1985)

- A The skyline is deflected through an angle =  $\alpha + \beta$  which should not exceed  $90^\circ$ .  
The tension in the guy ( $S_b$ ) is given by:

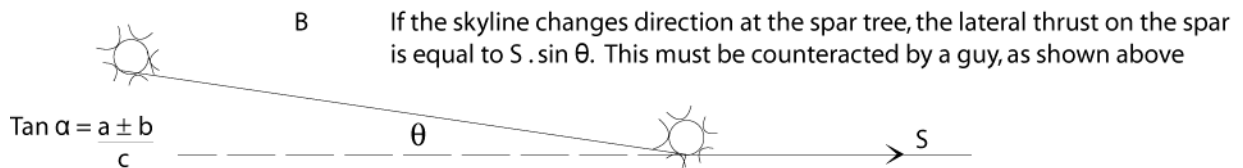
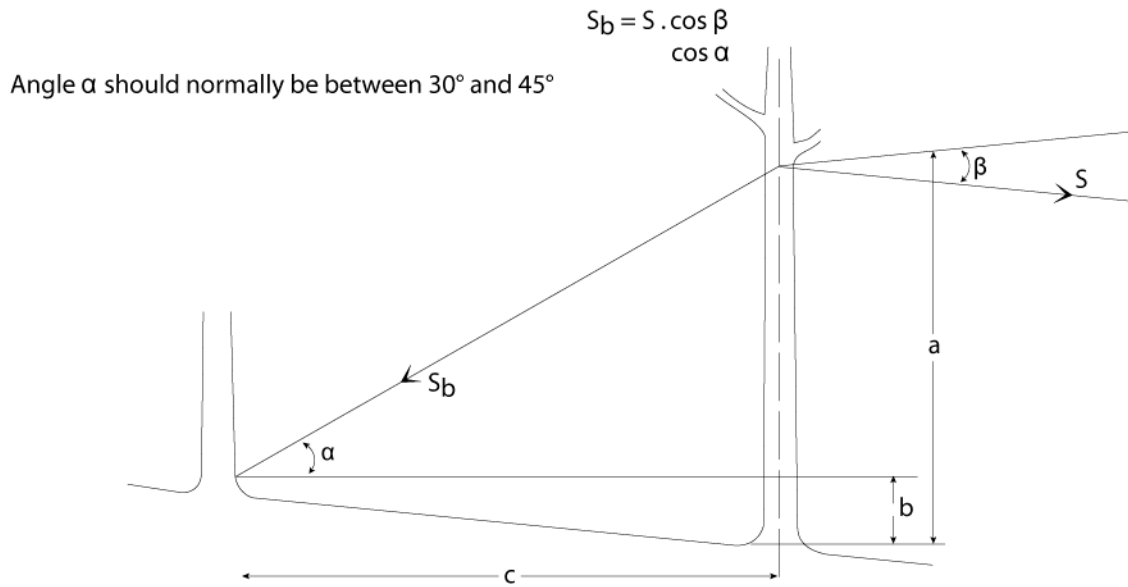

Correct skyline tension is important, as low tension results in excessive wear at supports and high tension reduces the rope life.

The following tables and methods of skyline tension calculation will help cableway users.

Table 3 gives the vertical force on a spar tree for a given deflection angle and skyline tension (Samset 1985).

**Table 3** Vertical force of a skyline on a support

Skyline tension (kN) Deflection angle (°)	40	60	80	100	120	140	160
	Pressure on support (kN)						
5	3	5	7	9	10	12	14
10	7	10	14	17	21	24	28
16	11	17	22	28	33	39	45
22	15	23	30	38	46	53	61
30	21	31	41	52	62	72	83
45	31	46	61	77	92	107	122
60	40	60	80	100	120	140	160
90	58	85	113	141	169	197	226

The recommended mid diameter in cm for a given section of tree under different vertical loads is shown in Table 4 (Samset 1985).

**Table 4** Mid diameter in cm

Vertical force (kN)	Height to cable attachment point (m)					
	<5	6	8	10	12	15
	Mid diameter (cm)					
10	14	15	17	19	21	24
20	16	17	20	22	25	28
30	18	20	22	25	27	30
40	19	21	24	27	29	33
50	20	22	25	28	31	35
70		24	27	31	34	38
100		29	30	34	37	41

The strength of spar and intermediate support trees depends on their ability to resist buckling. Table 4 assumes that the taper from the mid-point upwards is not more than 1 cm per m. The two tables above are derived from Samset (1985) and Pestal (1961). During the initial survey of the site prior to felling, the larger sturdier trees should be selected for spars.

Spar and support trees at final felling are sometimes lost through windthrow. It may be necessary to reduce the tree crown to reduce windthrow risk, which is a specialised operation.

### Supports

Skylines can be supported at intervals on saddles suspended by various means. Cableways using non-locking carriages and low skyline cable tensions can use lighter supports. For comparison, some Central European systems use skyline pre-tensions in excess of 9 tonnes to carry fully supported loads.

Intermediate supports should only be used when necessary. Even the light supports used in British practice increase the setting-up time and reduce the speed at which loads can be taken out. On flat ground one support is generally required for every 100 m of rack length. However for a 300 m rack 1 support at 150 m would be sufficient. The position of supports should be decided when the rack system is laid out. Several low supports are often better than a few high ones.

On clearfell sites, a line of potential support trees should be left on ridges, to give adequate choice where the precise rack alignment cannot be judged in advance.

Various types of support can be used.

**M type:** this is the most common (Figure 14A), and much used in thinning. The normal rig is 13 mm diameter nylon rope running through shackles on nylon rope strops hung on the rackside trees. If loads are heavy as in pole length or whole tree extraction, the nylon is replaced by 8 mm steel wire rope and pulley blocks are used for steel wire strops.

**Figure 14 A M Type**

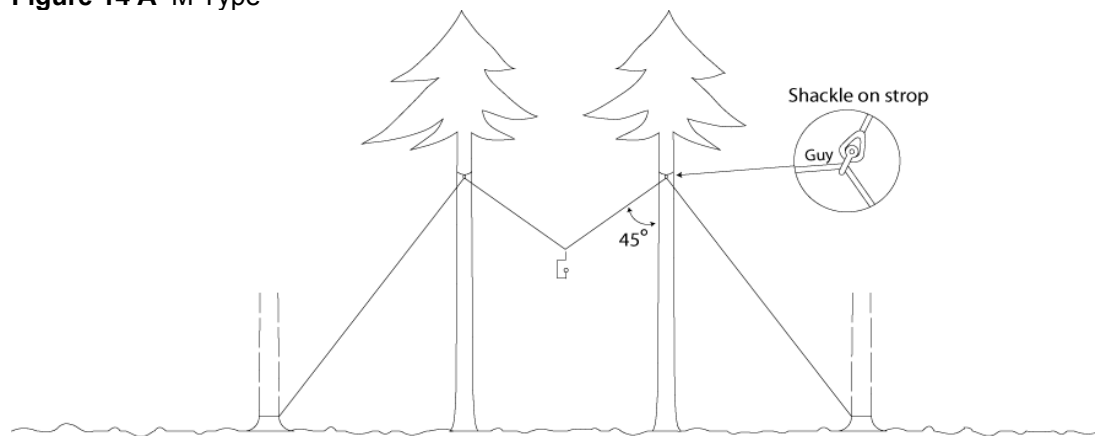

A weak support tree can be reinforced by lashing a pole, butt uppermost, to it. Rigging angles should ideally be 45° but this is not always possible. Small support trees may need additional guys to counteract buckling forces generated when the skyline is fully laden. When a non-locking carriage is used and the load less than 0.5 m<sup>3</sup>, support trees of 20 cm DBH or more do not need additional guys.

**Single pole:** a pole of 8 m length and 15 cm top diameter is used, leaning towards the skyline cable (Figure 14B). The skyline and hanger are lifted by the front guy which runs through a pulley block hung from the top of the pole. A second pulley can be fitted at the top of the hanger to give a 2:1 lifting advantage. Guys are of 8 mm steel wire rope. A variant of this type, useful in final fellings, uses a tree cut at stump with about 3 cm of wood left as a hinge; the tree is tipped over by the front guy and held in place by two tail guys.

**Figure 14B Single pole**

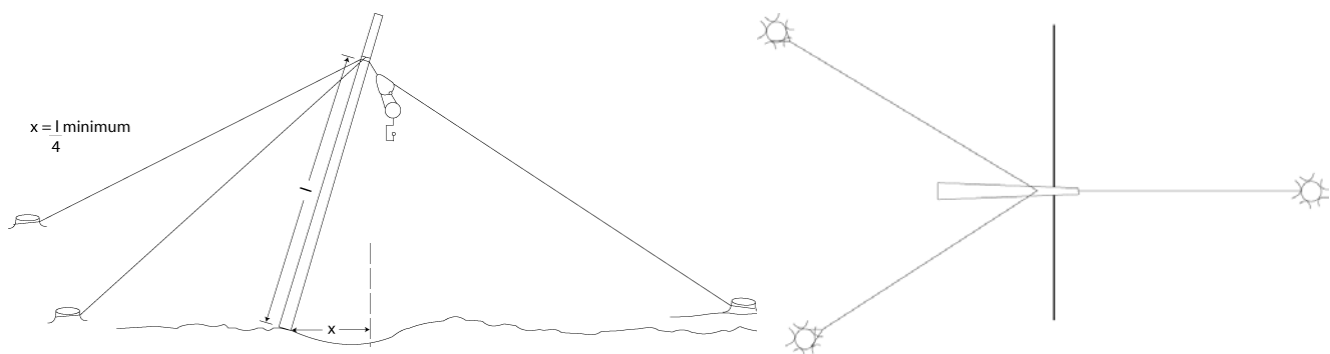

**A – Frame:** made by lashing two poles together (Figure 14C), or by using a metal collar. The support can straddle the line, but is better placed along the line like a single pole support and when used this way, only one tail guy is necessary. Top diameter of the poles should be at least 10 cm at 6 m length. This support can be quickly erected as a tail spar substitute in highlead operations on windblown sites.

**Figure 14 C A-frame**

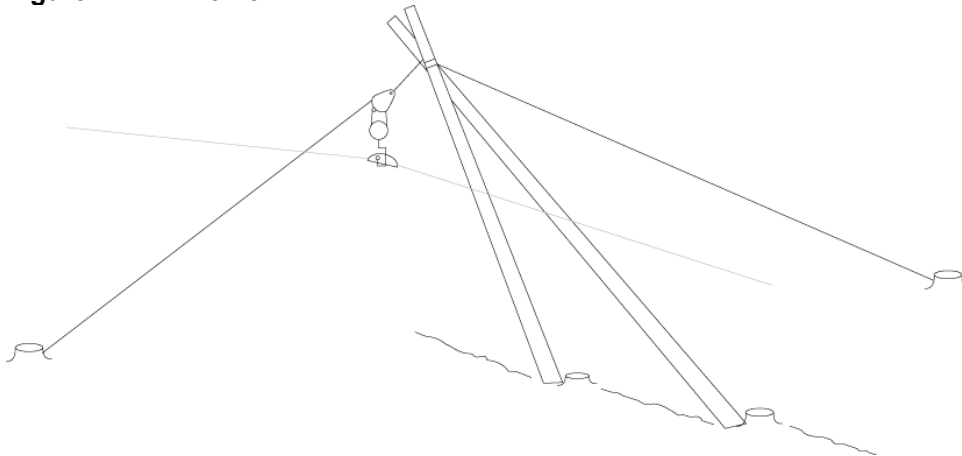

Single strop: this needs a single strong tree within reasonable distance of the bearer cable. It is, in effect, a wire rope version of the single pole support (Figure 14D).

**Figure 14 D Single strop**

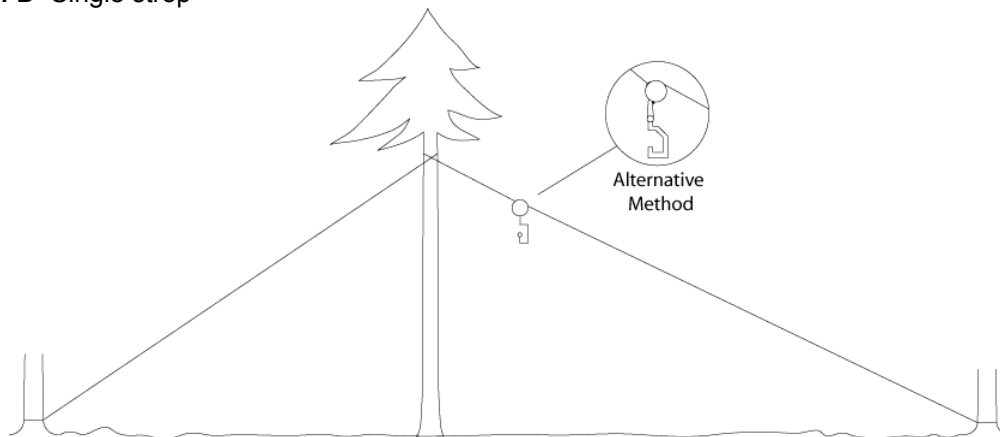

Nylon strops are lighter to carry and are more elastic and flexible than wire strops. Wire ropes ensure that support height is maintained when the load passes over the support, but are more likely to cause spar tree failure if the load jams at the support.

The rope tensions of light cableway systems in Britain enable trees, stumps and artificial anchors to be used. Anchors (Figure 15) should directly oppose the applied force where possible. The following points should be noted:

- Guy ropes should be fixed low down and close to the root of anchor trees or stumps.
- The tension on the guy line should ideally be parallel to the ground surface, however in practice the angle that is formed between the guy rope and the ground should be less than 45°.
- Anchor trees generally have a greater holding capacity against an uphill force compared to a downhill pull.
- The holding power of anchor trees is greater on deeper, drier soils than on shallow wet soils.
- Broadleaves and pines are usually stronger than spruce; avoid dry or rotten stumps.

- Holding power depends on the root spread and is usually greater with trees of larger diameter. Torsional forces should be avoided.
- Vibrating pulling forces may gradually loosen a tree, particularly if the guy is at a steep angle to the ground.
- Where there is danger of an anchor tree blowing down it should be felled about one metre from the ground.
- The anchors should always be inspected after severe weather conditions such as high rainfall, wind, frost and snow.

**Figure 15** Skyline anchor trees. Right and wrong use of multiple anchor trees (Samset 1985)

A Incorrect alignment of the guy rope causes lateral thrust on anchor trees a and b

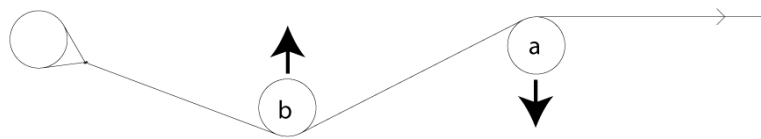

B Improved guy alignment reduces lateral forces



C Anchor tree C is subject to an upward force which will tend to uproot it reducing its holding power. Angle of the guy to the ground is too great.

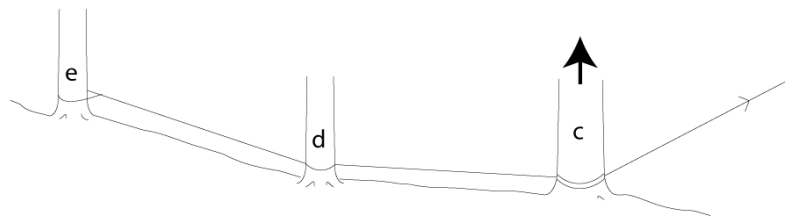

D Using only trees d and e improves the guy rope angle. If there is any doubt about the holding capacity of d, it can be guyed back as shown

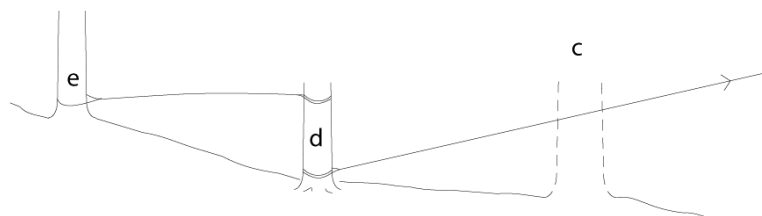

Recommended maximum horizontal forces at stump height for anchor trees are given in Table 5.

**Table 5** Horizontal forces related to stump diameters and soil conditions

DBH (cm)	Horizontal force	
	Max. pull on average soils (kN)	Max/ pull on best soil conditions (kN)
10	3	5
20	13	20
30	30	45
40	53	80
50	83	125
60	120	180

The figures in Table 5 are based on guidance from Pestal 1961 and give a good indication of the relative holding power of trees with stumps of different sizes. The absolute holding power varies a good deal and can be much less on soft wet ground. This can be overcome by:

- Using more than one anchor.
- Aligning the anchor as closely as possible with the line of the cableway cables.
- Using a spike at the rear of an anchor tree to prevent the guy rope slipping upwards. If using a stump, cut a notch. Another method is to thread the guy or strop under a main lateral root on the side opposite the pull.

The effectiveness of a guy depends on its angle with the ground. The rigger should aim for angles of less than 45°, formed between the guy rope and the ground. When rigging a tail-spar, the angle of the guys to the skyline is important (Figure 16).

**Figure 16** Diagram and formulae for tailspar anchors

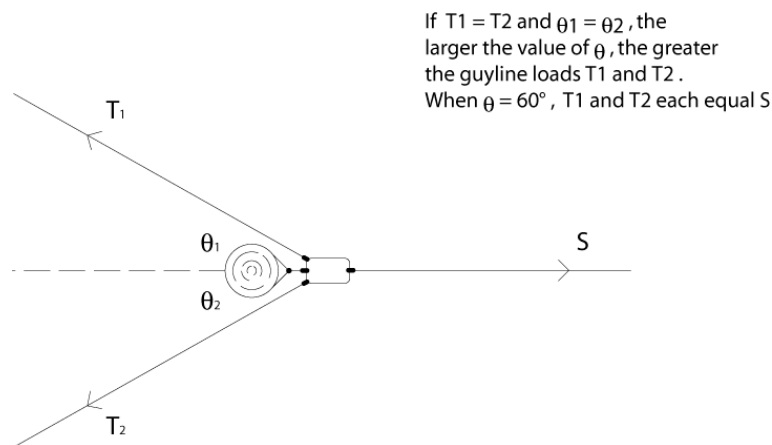

The angle formed by the skyline guys should be relatively small where possible, to minimise tension in the guys and forces on anchor trees.

Support and anchor trees that will be of use in later thinnings and final clearfell should be given as much protection as possible by using the following:



- Wire strops covered with rubber hose or a plastic sleeve and used with packing will reduce bark damage. Strops should have a thimble eye for an appropriate shackle (usually 2 tonne) with a loop on the other end, for the thimble eye to pass through.
- Uncovered wire strops should be used with half round pieces of wood placed around the stem, to reduce damage to the anchor tree.
- Polyester fibre round-slings are ideal for cableway rigging provided they are used with care. They are lighter, cheaper, more flexible and comfortable to handle than wire. Signs of strength deterioration are immediately recognised. Although they do not damage the stem as readily as wire rope, protection is recommended for long term support and anchor trees. They are available in a range of load capacities from 1 tonne to 8 tonne.

Artificial anchors (Figure 17) are used when anchor trees or stumps are too small or not available:

- Plate and pin ground anchors: Two plates usually suffice for most conditions, but the number can be increased where forces involved are large or the ground is very soft. Use at least 4 plates to secure a tight skyline.
- 'Dead man' anchors: are suitable for cableways with greater forces such as tight skylines where no suitable anchor trees or stumps are available. They may be the only practical means of anchoring on open ground e.g. on a field beyond the edge of a forest. A trench 1.5 m deep is sufficient on firm soil and on soft ground, but where the anchor has to resist a downhill pull a deeper trench is required.
- Rock bolt anchor: this is an eye-bolt with a vertical slot in the base of the shank, into which a wedge is placed. When the bolt is hammered into a pre-drilled hole the wedge expands the shank, holding the bolt firmly in the rock. This type of anchor is suitable for all systems where good rock is present, and has greater potential than is generally realised. They should be clearly marked so that they can be found and used in subsequent operations.

**Figure 17** Anchoring methods (Samset 1985)

A Plate and pin ground anchor

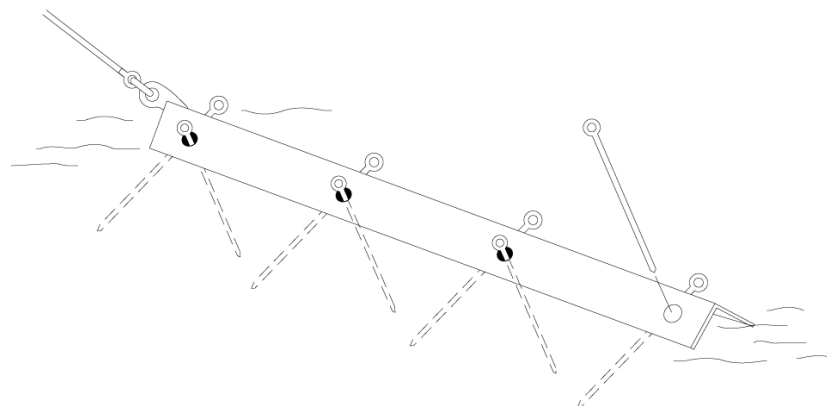

B 'Dead man' anchor

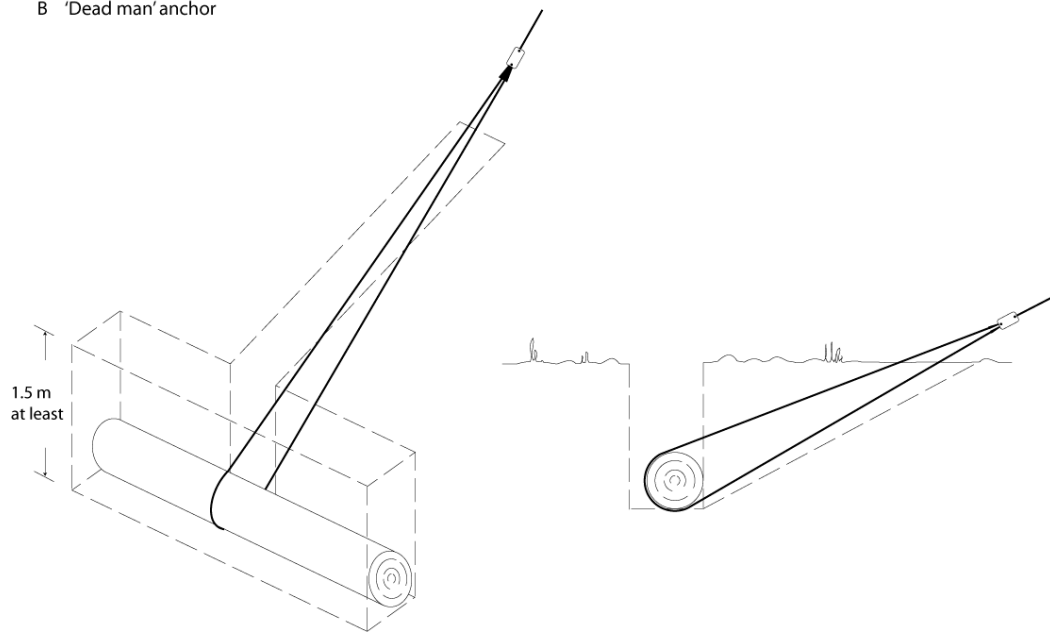

C Rock bolt anchor

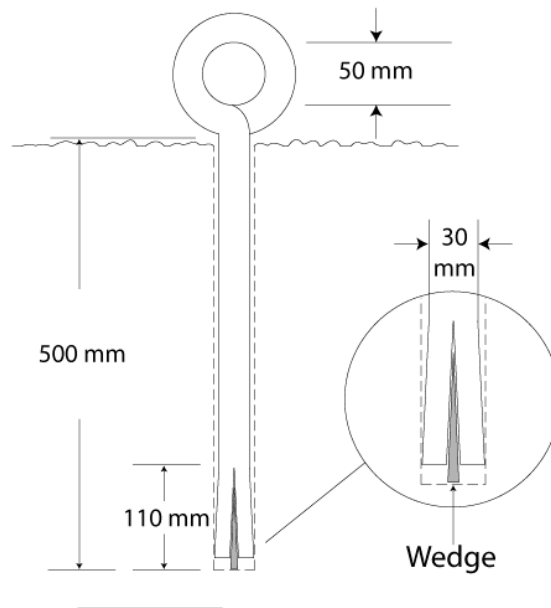

A guyline or skyline in contact with the ground should be protected with wooden bearers to avoid chafing on the ground.

Table 6 gives guidance on the log dimensions for dead man anchors.

**Table 6** Log dimensions for dead man anchors

Skyline Tension (t)	Mid Diameter (cm) for Log Length (m)		
	2 m	4 m	6 m
3	22 (a)	27	
4	25 (b)	29	
5		32	36 (c)
6		34	38 (c)
7		35 (a)	40
8		37 (a)	41
9		39 (b)	43
10			45
12			47
13			50
14			52

- a. = Very hard ground
- b. = Stony ground
- c. = Very soft ground

In offset live skylines, the skyline cable passes from the winch through the deflection pulley block to the rack. The angle of the cable at the pulley block is never less than 90°, and often about 130°. This creates high stresses on the pulley block and its anchor. The strength of the skyline is also reduced at the point where it bends round the block.

The tension on the block can be almost double the skyline tension. Extraction of a 1.75 m³ load (one end only suspended) on a skyline pre-tensioned to 6 tonne maximum can have a force on the pulley of between 10 and 12 t. The spar tree must be stout enough to resist the downwards thrust imposed upon it.

The deflection block can be rigged as shown in Figure 18. In this example the root plate of the tree takes up about half the tension. This still leaves a substantial pull, which may have to be spread over several anchor trees, their number depending on their size and holding power.

**Figure 18** Offset rigging

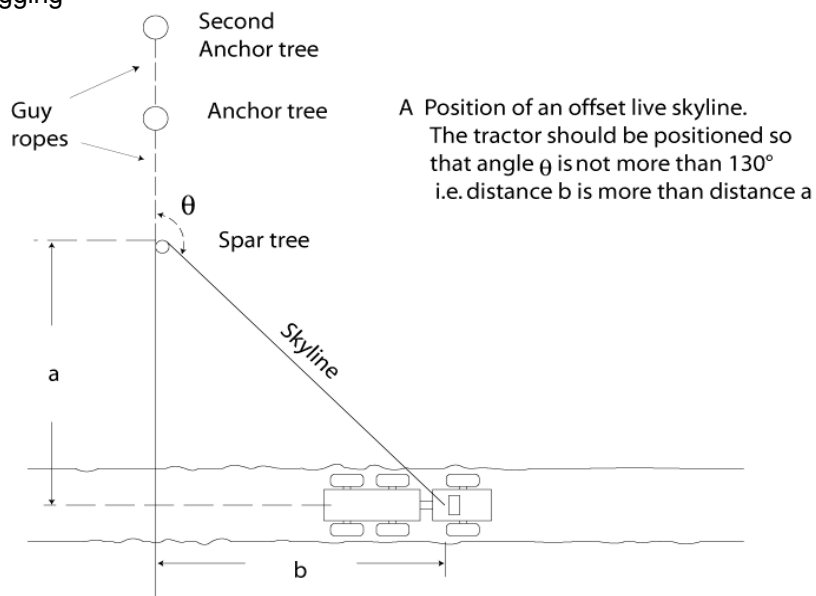

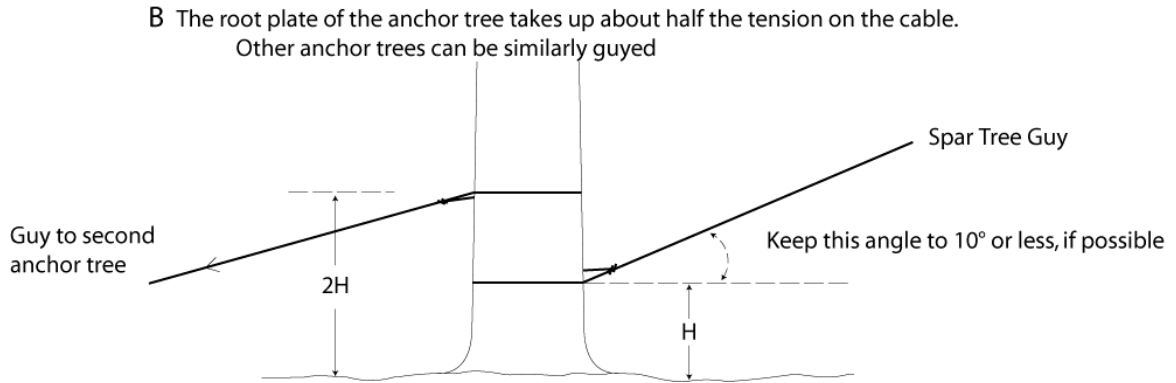

### Skyline Support Saddles

The saddle should match the skyline rope size, historically there were two sizes for the Iglad winch system. Ropes up to 13 mm in diameter are generally well supported by correctly set up saddles. Larger diameter ropes are less flexible and some method of containing the cable within the saddle is necessary.

Jubilee clips are not satisfactory because they can be damaged on outer surfaces by the carriage and worn from the inside by movement of the cable in the saddle.

Inverted J bolts are better but may become distorted and difficult to adjust.

Good cable support can be achieved by reducing the angle of deflection, (Figure 19) which is created when a skyline is under load. The largest deflection angles are created when a loaded carriage reaches a support saddle. The angle must be large enough (minimum  $2^\circ$ ) to create sufficient pressure to retain the cable within the supporting saddle when unladen and the maximum value should be less than  $30^\circ$ . Greater carriage speed can be maintained with a smaller deflection angle. A double support can be used to reduce the deflection angle.

**Figure 19** Deflection angle and double support (Samset 1985)

A Deflection angle at a skyline support

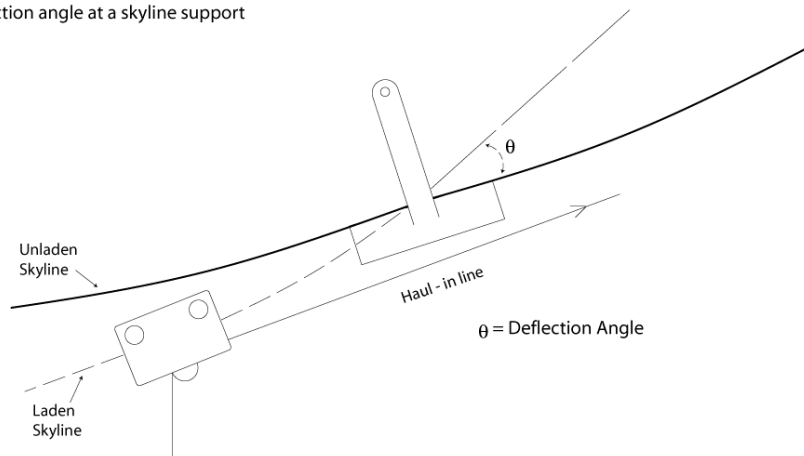

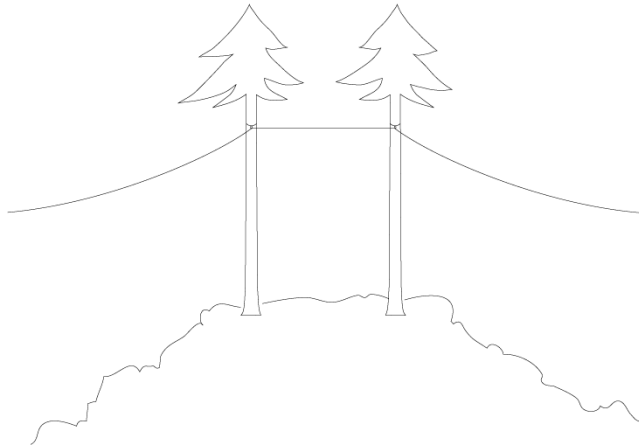

When a support point is too low, there is a tendency for the skyline to lift from the saddle when the load passes over the saddle. Experienced crews can anticipate this and choose the best possible support. It may be necessary to clamp the skyline in the saddle and even to anchor a support tree to reduce the incidence of it being lifted. It is important to impose a convex shape on the skyline to avoid this problem.

## CARRIAGES

Line carriages (Figure 20) for simple unsupported highleads or gravity systems can be made from two linked pulley blocks. Tight skylines usually have larger carriages designed to travel easily over the support saddles.

Locking carriages have various mechanisms to hold the load firmly in place once it is lifted clear of the ground. Faster haul-in speeds can be used and reduced tension is required in the haul-in to lift the load. This will improve rope working life and there is less wear on clutch and brake. The load is often fully suspended which places a greater load on the skyline cable which must be correspondingly heavier. Strong locking carriages can be robust, but they tend to be heavier, and they are more complex. It is also less easy to drop the load in an emergency, although a live skyline enables all lines to be dropped.

More sophisticated carriages are available from a variety of manufacturers in the UK and from overseas. They can have the following features:

- Fitted with an ancillary engine to drive the carriage on the skyline and drive a self contained haul-in winch.
- Carriage movement controlled by haul-in and haul-back winch ropes and fitted with ancillary powered haul-in drum to winch load to carriage.
- Carriage movement controlled by haul-in and haul-back winch ropes and fitted with a hydraulic accumulator powered by carriage movement. This stored energy is used to pay out the haul-in rope to the chokerman.

The ergonomic release of rope for the chokerman can be difficult to achieve and various carriages have been devised that enable the haul-in line to be automatically fed out from a separate drum. Some of these payout systems have a separate engine to power the pay out drum.

**Figure 20** Simple skyline carriages

**Chapelhall Highlead**

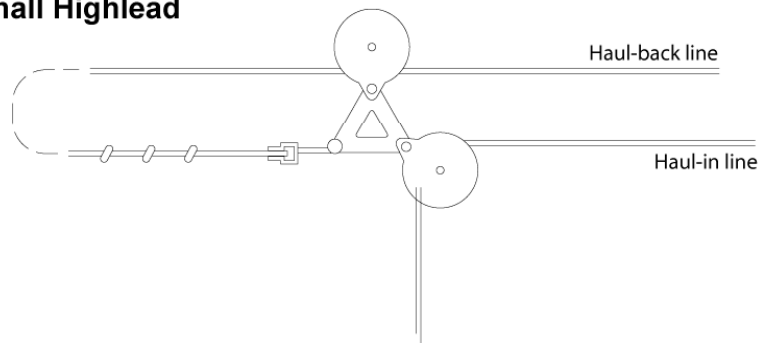

**Igland Highlead**

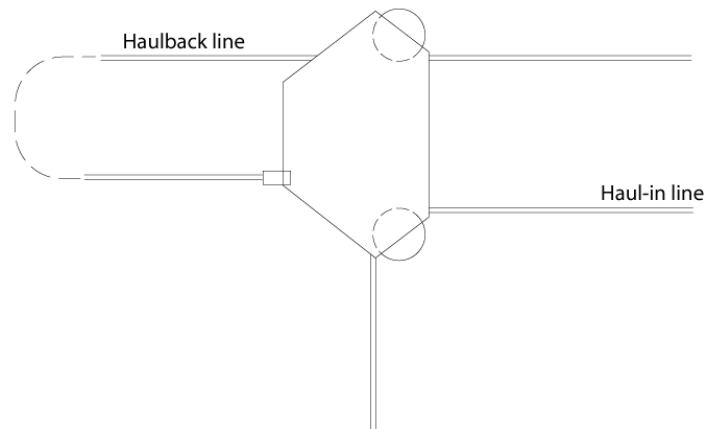

**Chapelhall Skyline (non-locking)**

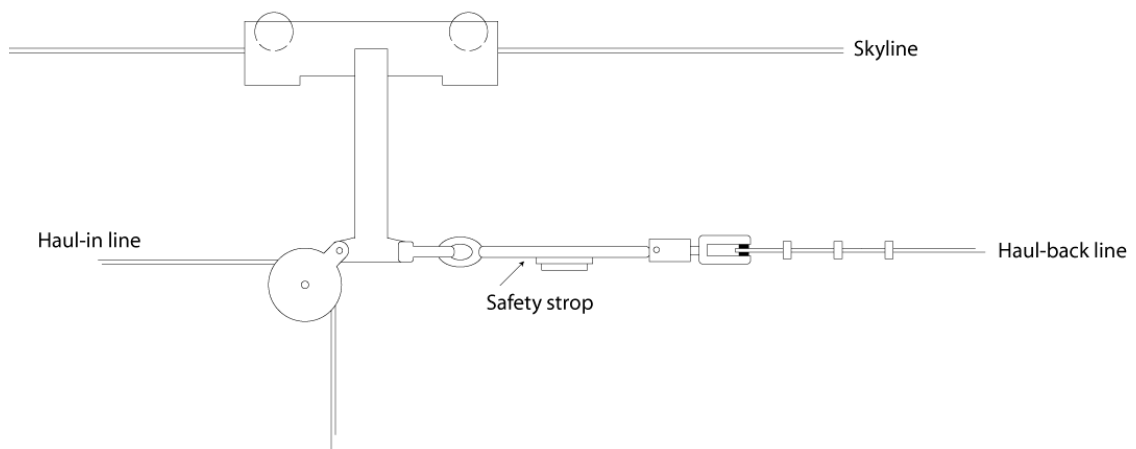

## CHOKERS

Wire rope and non wire rope chokers are noose type systems which tighten with force on the load.

Chain choker systems are manually tightened and held in place with keyhole sliders. Under force the chain choker does not constrict further on the load for grip. Grip is achieved by chain friction and/or snagging with the load.

A tag line is a length of rope with one or more choker systems and the tag line can be readily removed and attached to an extraction rope system. Tag lines can be used for pre-chokering, reducing unproductive winchman waiting time when the chokerman assembles a load.

All components must comply with the Machinery Directive 98/37/EC and be fit for purpose. They must indicate a safe working load (SWL) and comply with the Supply of Machinery (Safety) Regulations 1992 (SI 1992, 3070).

The following choker systems have been used:

- *Running hook, wedge socket eye and choker hook washer.* This is the simplest system and normally used in a high lead shortwood system. The washer protects the carriage when the load is being extracted.
- *Running hook and wedge socket eye and choker hook washer with sliding chain choker.* The chain makes it easier for the chokerman to pull down the end of the haul-in line from the carriage in skyline working and the chain can also be used as an extra choker. The entire choker assembly is attached to a 5 to 6 m long tag line. This method is suitable for shortwood extraction.
- *Soft eye and pin with detachable chokers.* Detachable hooks are used with lightweight fibre (e.g. polypropylene) rope chokers, the number varying according to the size of pole. Extraction is normally tip first. By pulling out the retaining pin at the landing, the haul-in line is winched free from the chokers and a second set attached for quick return to the chokerman.
- *Bardon wire rope choker.* The choker is a 2 m length of wire rope with a steel pawl at each end of the rope with a slider between the two pawls. One pawl is passed around the tree and locked in the slider. The other pawl is locked in a slider on the main extraction rope. When tension is applied to the choker it tightens on the load.
- *The Grampian choker hook* used with lightweight polypropylene rope chokers. It slides easily over the locking ball used on certain locking carriages. Safe working load is 1.5 tonnes.
- *The Fleming quick release hook* automatically opens when the load touches the ground and the haul-in line slackens. The choker chain is then withdrawn from the load by the winch. At the chokering area the empty chain is replaced by a loaded one and the cycle repeated. If the load is turned through 90° prior to dropping, release of the hook becomes erratic.
- *Mullholland quick release choker.* This is an adaptation of the Fleming quick release hook. The choker chain is attached to a spring loaded plunger release system and looped around the load, the end of the chain is positioned in the release mechanism. The chain is released and the load discharged when the plunger strikes the ground.
- *Self gripping tongs.* The 'Skogsmateriel' type 4711, with a 57 cm spread, give an immediate and safe grip and will automatically release the load at the landing if the drop height is greater than 2.5 m. They are seldom used in Britain.

Chains and choker chain extraction systems were not traditionally tested or carry the SWL mark. This is gradually changing due to the Supply of Machinery (Safety) Regulations 1992 (SI 1992, 3070), with many of the manufacturers producing equipment that conforms to the regulations.

Chains are expensive, but useful for large trees.

Wire rope chokers with Bardon-type sliders can be used for large timber. They are more difficult to handle when compared to polypropylene chokers.

When trees are less than 0.3 m<sup>3</sup> it is often difficult for the crew to assemble efficient load sizes. Extraction efficiency can be increased by:

- An organised system of felling in clearfell situations
- Good directional felling, to bring the tips of poles together so they can be attached with a single choker. Butt-first extraction results in loads that are too small.
- Pre-chokering with detachable chokers.
- Using taglines 10 to 15 m long, which the chokerman can pre-set and attach to the haul-in line with a quick coupling link. These minimise waiting time when assembling scattered poles into larger loads.

Chokering systems are shown in Figure 21.

**Figure 21** Chokers and tag lines

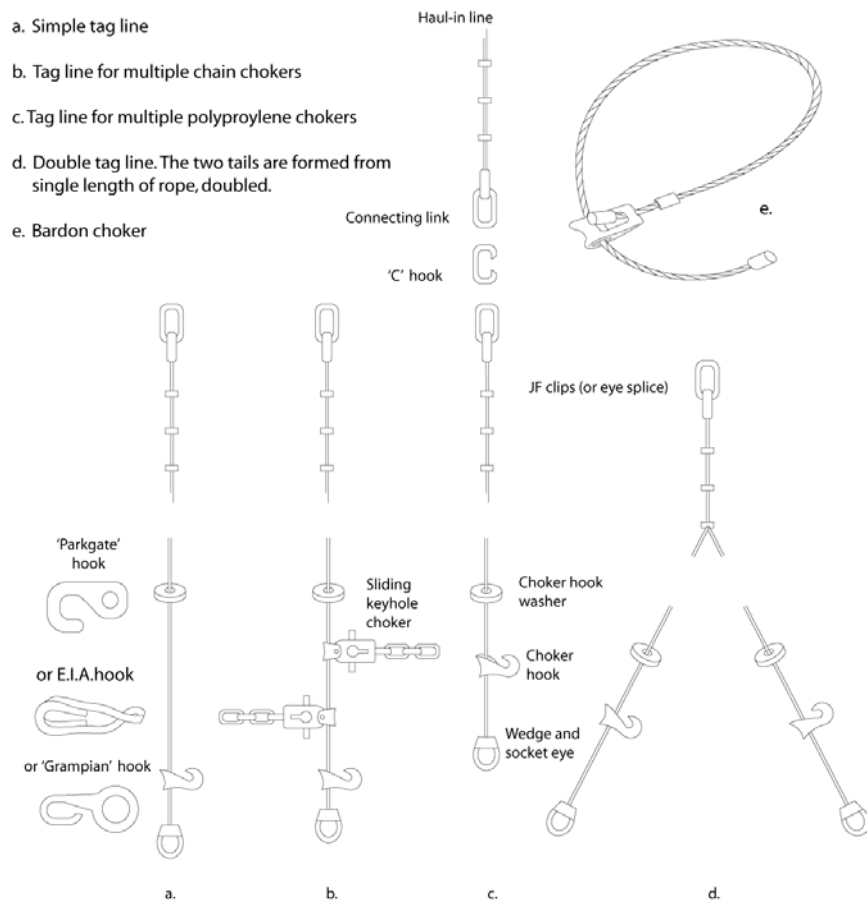



Taglines can improve output and should be used where possible. Experienced chokermen can set chokers so that poles or sawlogs avoid obstacles such as stumps and rocks during extraction.

A combination of tag-lines and polypropylene chokers give the best results for smaller crops.

In comparison, more time is required to choker when using chain chokers, keyhole adjusters and wire rope chokers. However, they are the only option for larger trees.

## **USING THE CABLEWAY**

The essential operations for cableway working are described in sequence.

### **Setting Up Procedures**

#### Highlead

The set up procedures for this system are less complex when compared to skyline systems, see Figure 4 (a).

The tail spar tree is identified. A nylon strop and a Kuplex ring are placed around the tree and a pulley attached. The tail spar is anchored with a guy rope.

The haul-back line is pulled out and threaded through the tower block on the tractor and then through the pulley at the tailspar tree.

The rope is returned to the winch, the end of the rope is fitted to the carriage. The carriage is attached to the haul-back by one of the pulley wheels.

The haul-in rope is fed through the other pulley on the tower and then through the other second pulley wheel on the carriage. A choker ring washer and wedge eye socket is fitted to the end of the haul-in rope, to prevent the rope being pulled back through the carriage.

The tractor is positioned in the middle of the rack at the roadside. The tower is anchored with guy ropes to trees or stumps.

#### Skyline

The tail spar is anchored (Figure 22) with a guy rope. A solid snatch eye can be attached to the tree and the skyline passed through the snatch eye and secured with a suitable anchor at ground level.

A strop with a Kuplex ring can be rigged with a tail guy to an anchor tree and the tail block can be used for one of the following:

- Skyline (or snatch block used).
- Highlead haul-back.
- Skyline haul-back.

**Figure 22** Tailspar fittings

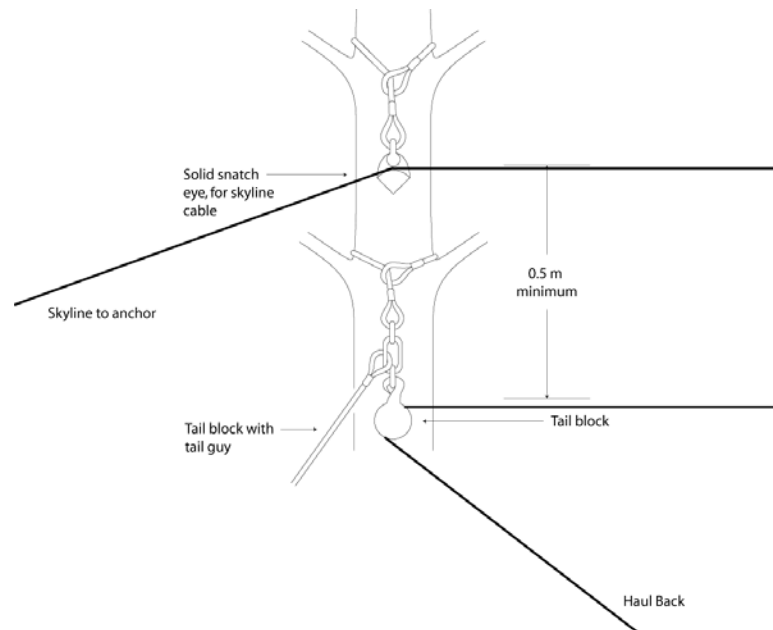

At the same time, the winchman positions the tractor so that the tower head blocks are in line with the centre line of the rack. He fixes the tower guy ropes to anchors, tightening the guys with auxiliary or manual winches or by moving the tractor. Anchor ropes must be kept tight and secure.

Trailer mounted winches such as the Timbermaster, Alp and tractor mounted winches can be offset at an angle to the rack. This is useful if stacking space is limited or if the tractor will have to be moved to let traffic pass because it can be moved without dismantling the skyline rigging. The tower guys must be adjusted where necessary to compensate for an offset working position.

The tractor should be placed so that the tower is vertical and the winch drums are level. On uneven ground wedges and blocks can be used under the wheels to level and stabilise the tractor and winch. This is good practice and particularly important if the winch design allows the drums to lean against the winch clutch plates, which will result in the clutch not disengaging properly. If the clutch is not completely disengaged, it is very difficult to pull off the rope by hand. The ropes may also spool unevenly.

When the tractor is correctly positioned, the foot and hand brakes are applied and locked.

The chokerman rigs the tail block on the tail spar and fastens the guy ropes to the anchors, tensioning as appropriate. The haul-back side pulleys are fixed to ensure the free movement of the rope (Figure 23). The pulleys should be positioned to ensure that the rope is not pulled along the ground or over obstacles. At the first set-up on a logging area he may make a temporary tail block rigging so that a ladder, guy ropes and other gear can be sent out using the winch. He carries these items over to the next tail spar when setting up in subsequent racks.

The winchman then tightens the haul-back line. The chokerman checks that it is clear and returns to the start of the rack.

**Figure 23** Position of side pulleys in relation to tower guys and tailspar guy

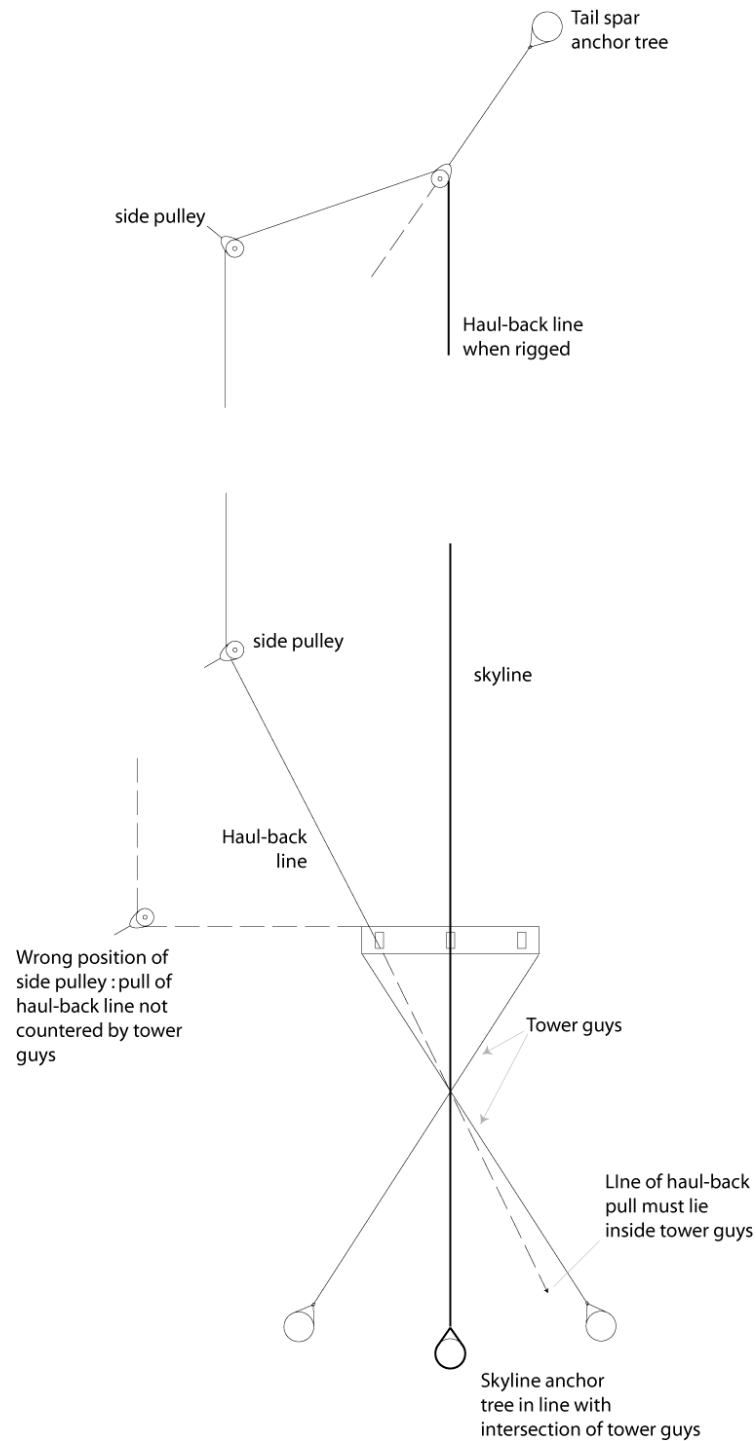

On steep ground it may be necessary to stack and perhaps delimb and crosscut extracted timber on the roadway, with the winch in an offset position. This requires a good pre-selected spar tree, on the centre line of the rack, on which blocks for the haul-in and haul-back lines are mounted. It may be possible to stack timber above the road if the position of the spar tree allows.

This spar tree must be accurately guyed to withstand the angled forces of the hauling lines, and rigged so that the blocks can assume the working plane of the ropes. The winch should be placed so that the operator is not working within the 'bight' or angle of the cables.

Figures 24 and 25 show two different routes for the haul-back line when the tractor is in an offset position.

**Figure 24** Chapelhall skyline system. Offset rigging when haul-back line goes out on opposite side of the rack to the tractor

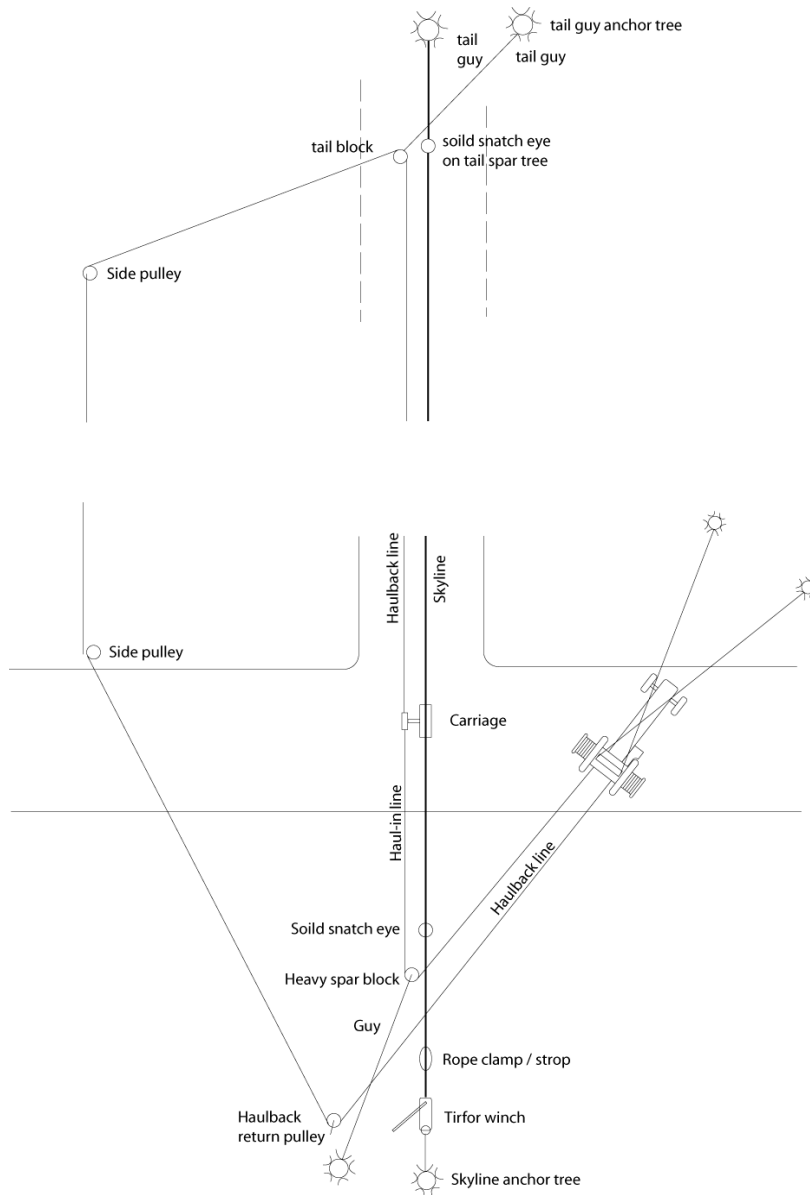

**Figure 25** Chapelhall skyline system. Offset rigging when haul-back line goes out on same side of the rack to the tractor

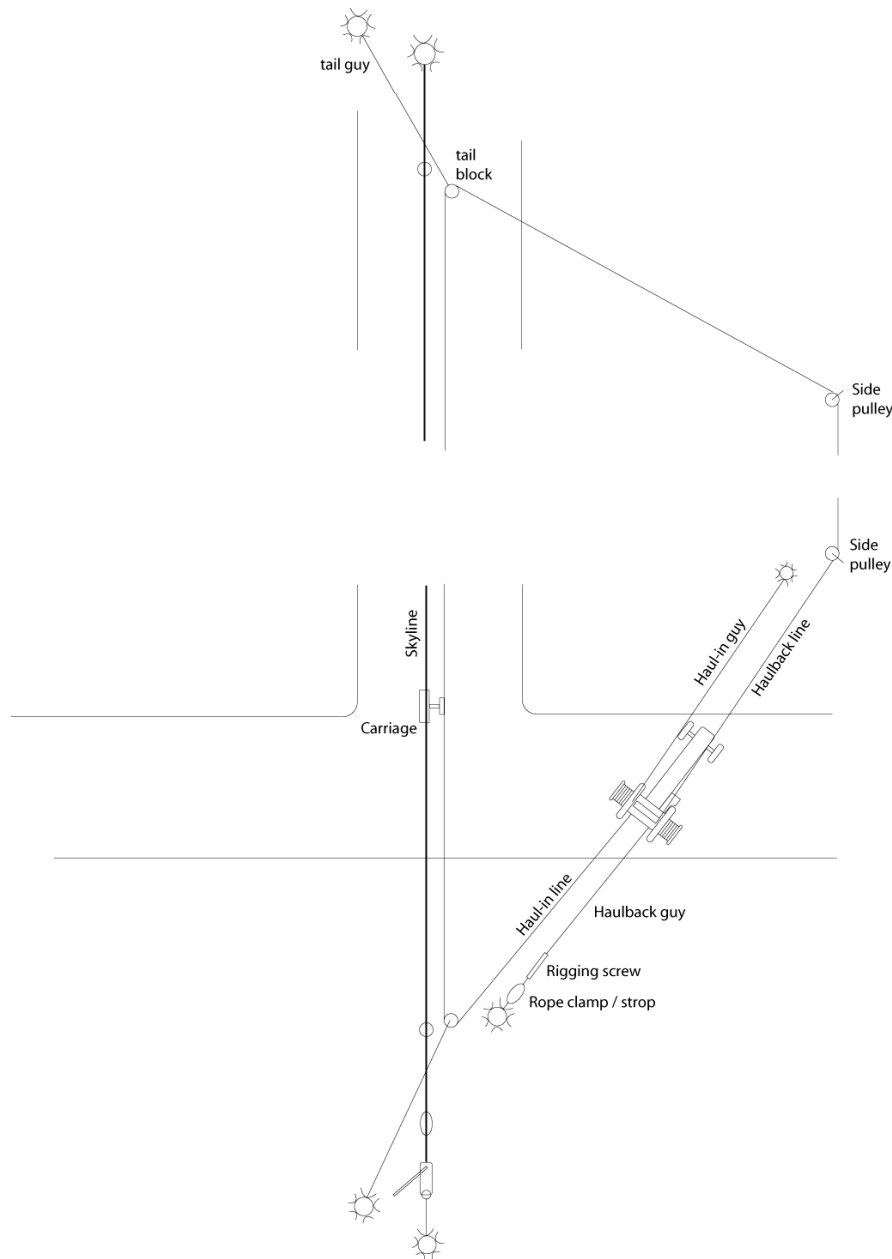

Having rigged the haul-back line as above, the skyline and haul-in line are then attached to the haul-back line. A metal triangle with 50 cm sides and a shackle at each corner is often used as a means of connecting these cables and reduces the risk of tangling. Alternatively, the system described in Figure 26 can be used. Winding in the haul-back line takes the skyline out to the tail spar. When the rigging of the tail spar is completed, the skyline can be anchored at both ends. The haul-in line then takes the end of the haul-back line back to the winch.

It should be noted that after setting up the skyline the system should be checked to ensure that the haul-in and haul-back ropes have not crossed over the skyline rope. Crossed ropes will create avoidable friction and rope stress when the winch is used and the skyline will have to be dropped and re-tensioned, after the haul-in and haul-back lines have been realigned.

**Figure 26** Method to pull out skyline rope with haul-back line

a How the skyline is secured at the junction of the haul-in and haulback lines

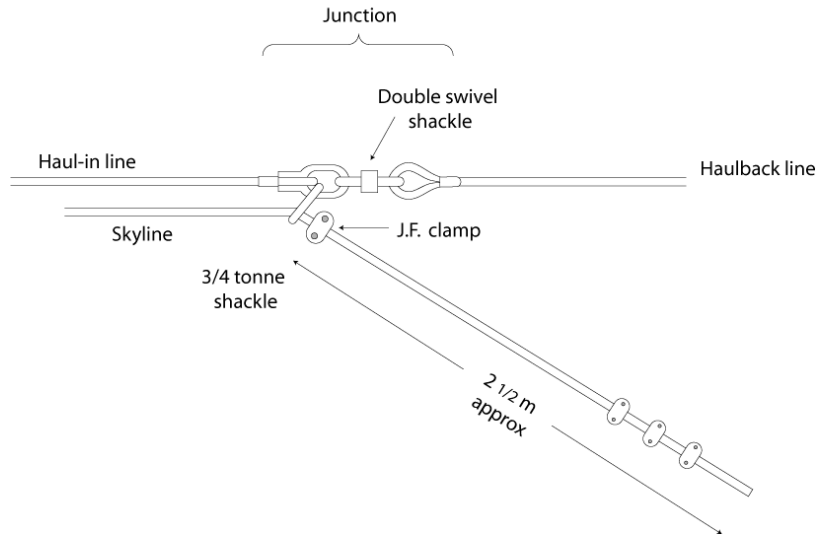

b Chokerman pulls off sufficient length of skyline rope for the skyline anchor tree to be reached

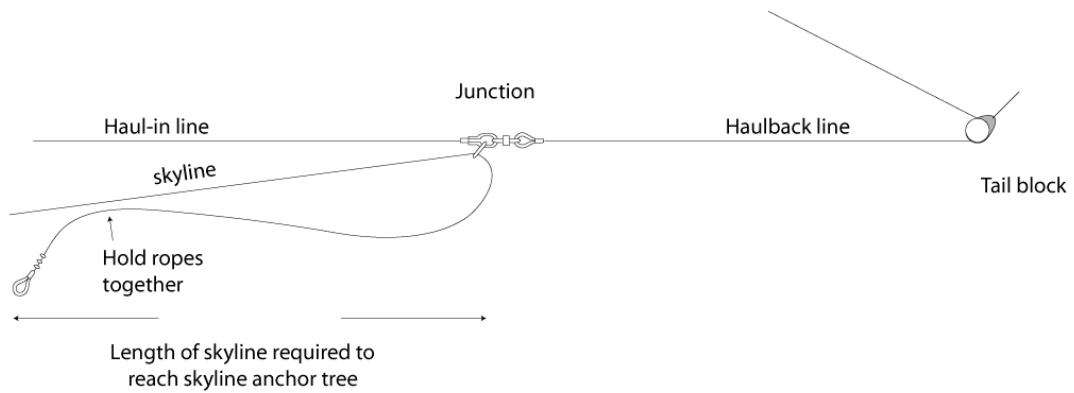

Intermediate supports are erected, starting with the first and last supports, then any others required. For downhill extraction it is important to erect the support nearest the tail spar first, so there is enough slack in the cable for one-man rigging.

To make the landing of produce easier with quick release chokers when extracting uphill, a support at a similar height to the tower is placed near the winch. This increases the drop height, improving choker release when the trees land on the ground.

The carriage is fitted onto the skyline and the haul-in and haul-back lines attached. The skyline is then tensioned by the cableway unit if it is equipped with a powered skyline drum, or by a separate manual winch such as a Tirfor. The carriage is then run through the supports to check that the system is functioning. It is then ready for extraction.

The rigging of an offset skyline requires care, to ensure that lateral tension in the running lines is balanced by secure spar tree guys. This is particularly important in live skylines, where the tensioned skyline forms an acute angle and subjects the anchor tree(s) to forces greater than the skyline tension.

In thinning, racks can be worked in groups of 5 or so (Figure 27), using a longer haul-back line than standard. The haul-back line does not give support in a tight skyline and does not have to run in the same rack as the skyline. Using this system, the haul-back line is reset on every fifth move, saving time and effort.

**Figure 27** Diagram of a 5 rack set-up

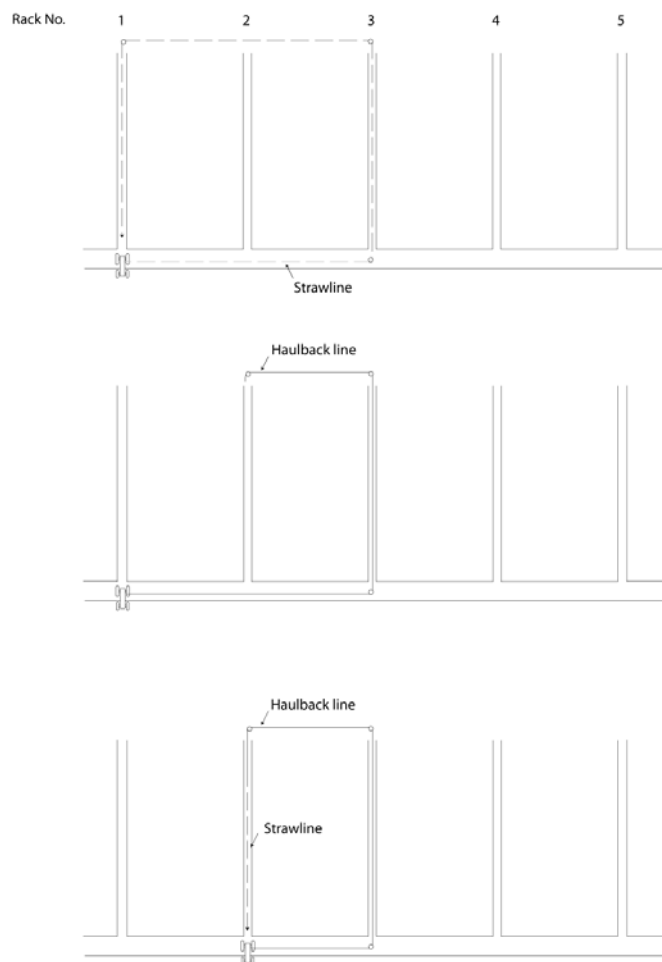

The following sequence is used for a multiple rack set up:

- The tractor is positioned and guyed as in Figure 27. The straw-line is taken from the tractor and up Rack 3, through a block on the tail spar tree, across to and down Rack 1 to the tractor, using pulley blocks where appropriate.
- The haul-back line is attached to the straw-line and the latter winched in, taking the haul-back line out to the tail spar of Rack 3 and back by way of Rack 1.
- When extraction of Rack 1 is complete and the skyline cable taken down, the haul-back line is wound in until the end is at the tail spar tree of Rack 2. Chokerman secures the end with a turn round the spar tree.

- The tractor is moved and positioned on the road at Rack 2. The winch operator takes the straw-line up Rack 2, meeting the chokerman who takes it through the tail block on Rack 2 tail spar tree.
- The chokerman attaches the straw-line to the end of the haul-back line and signals to the winch operator that connection is complete.
- The winch operator winds in straw-line, bringing the end of the haul-back line down Rack 2.

The skyline can be moved from rack to rack using the haul-back rope (Figure 28) to reduce set up time and manual handling.

**Figure 28** Moving the skyline to the next rack using reeving blocks

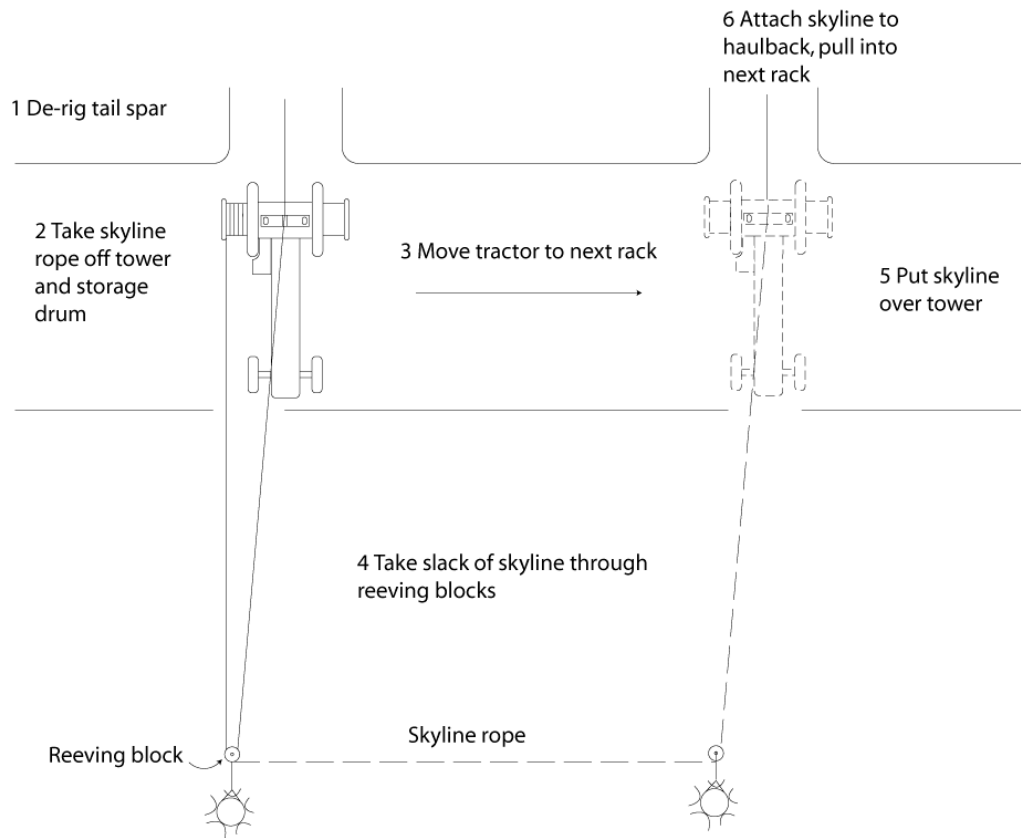



## Extraction

The extraction sequence is as follows:

- Winch operator checks that the working area is not obstructed and that he is not within the angle of the tensioned haul-in rope.
- Winch operator sends out the carriage until signalled to stop by the chokerman, who then pulls out the haul-in line or hoist rope until the tag-line linkage is reached. He takes off the empty tag-line and attaches the one he has previously choked to the load.
- Chokerman moves to a safe position; clear of all moving wires and protected by standing trees and clear from the haul-back pulleys. He signals to the winchman to haul-in and watches the load moving safely to the carriage.
- Side hauling must be done at minimum engine speed (tick over). Extreme care is needed when side hauling close to the tractor. If large loads have to be side hauled close to the tractor, an extra guy should be rigged to oppose the side pull. The chokerman signals to the winchman when the load is 'in the rack'. The winchman then accelerates the tractor to maximum speed, monitoring the rope 'pick up' and 'pay out' of the winch drums.
- Chokerman must keep at least 2 m (in thinning) and 4 m (in final felling) away from the skyline when the cables are moving. **He must not** place himself within the angle of the tensioned haul-in rope, within 20 m of the tailblock unless protected by standing trees, or stand under intermediate support wires or their guy ropes.
- The chokerman watches load progress, during side-haul, signalling to the winchman as appropriate if there are any obstructions to be overcome. He must not attempt to free an obstructed load when the haul-in rope is under tension. He then takes the empty tag-line to the next load.
- The chokerman attaches chokers to as many loads as possible and awaits the return of the carriage.
- When the load reaches the stacking area the winchman releases the chokers, uses the winch to pull them free from under the load, and sends the carriage and empty tag-line back to the chokerman.

The winchman aims to keep the load moving smoothly with sufficient lift from the tension on the haul-back line for highlead systems to keep the front of the load clear of obstacles. Particular attention is needed when the loaded carriage approaches a support, because the skyline cable is at a steeper angle on the far side of the support. With a non-locking carriage it is possible to lower the load, pass the unladen carriage over the support, then lift up the load again to proceed; this is necessary only in difficult situations.

A minimum of two tag-lines are normally used, each with a wedge-socket eye on the end and a sliding hook, and supplementary detachable sliding chokers as necessary. The winchman should have a third tag-line assembly to send out to the chokerman if the regular one jams or is difficult to release at the landing.

Taglines are essential at distances beyond the first 50 m of rack; if they are not used, the winchman can wait for several minutes on every load while the chokerman attaches the load.

On short extraction distances (up to 150 m) the chokerman can usually pull off sufficient main line for load attachment, but at long distances the weight of the rope makes this difficult. Methods of overcoming this are described in the next section.

Some teams prefer to extract pulpwood bundles first from a short stretch of rack, then sawlogs, and repeating this pattern. This prevents the pulpwood piles being disturbed by moving sawlogs.

The sequence of extraction depends on where the chokerman needs to be at the end of the operation. The usual pattern is to extract the nearest section of rack first, then extract timber lying adjacent to this cleared section; then repeat, moving further out in the rack by stages. This puts the chokerman at the tail spar when the rack is fully extracted, ready for take down and moving gear to set up in the next rack.

### Line pay-off

When a highlead system is used, the carriage can usually be dropped to the ground for each load. The chokerman can usually pull out sufficient haul-in line to allow the load to be attached.

Skylines often need some form of line pay-off (Figure 29), particularly when extraction is uphill towards the road where any slackening of the haul-in line results in the carriage travelling further out under its own weight.

**Figure 29** Methods of line pay off

- A. A dangling chain or tagline is attached to the haul-in line. Chokerman stops the carriage at the chosen exit point for the load (a), pulls chain by hand and wraps round the adjacent tree (c) and holds. Winch man hauls back carriage to position (b). This pulls off length (a) - (b) - (c), the required slack plus extra to allow for rope running back when tension is released. Winch man returns carriage to (a), chokerman releases chain and pulls rope to choker load.

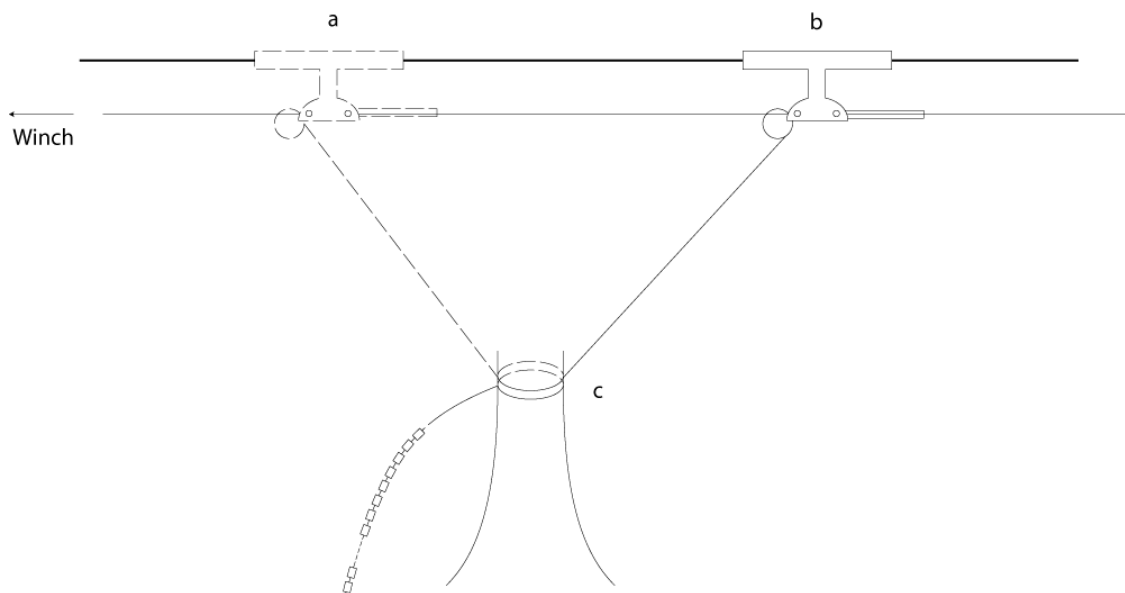

- B. The winchman fits a stop plate on haul-in line, at a suitable distance between tower and carriage by securing the haul-in rope around notches in the plate. He then pulls through the required amount of slack haul-in line and secures this round the stop plate notches on top of the previously secured haul-in rope, leaving enough rope dangling so that the choker can reach it. In the wood, the choker can pull the slack rope free of the stop plate to chokers the load. The stop plate is left in position on the haul-in rope.

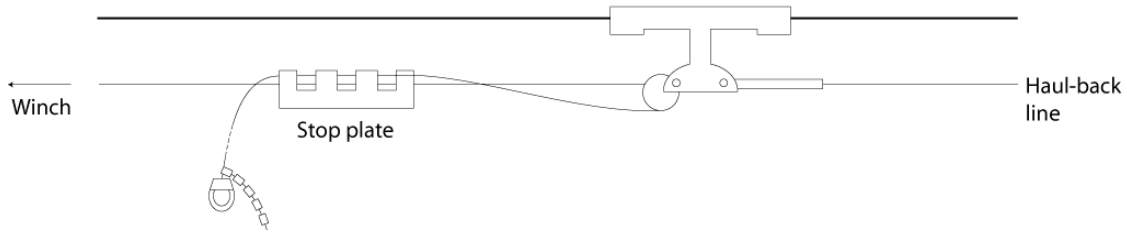

- C. The carriage is restrained by a large 'D' shackles on the skyline. This will not go over an intermediate support

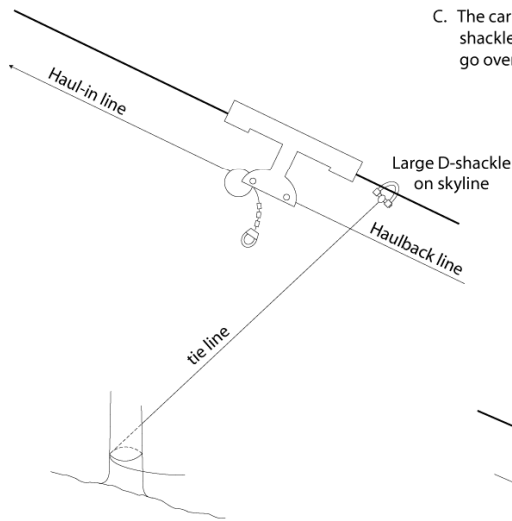

- D. The carriage is restrained by a pulley block mounted on the haul-back line which is not affected by intermediate supports

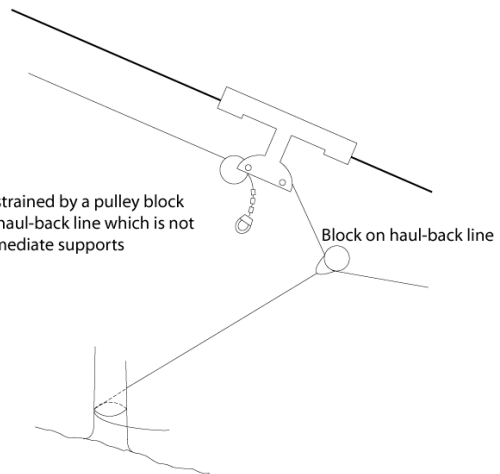

- E. The carriage is restrained by a purpose-built movable stop, which is not affected by intermediate supports

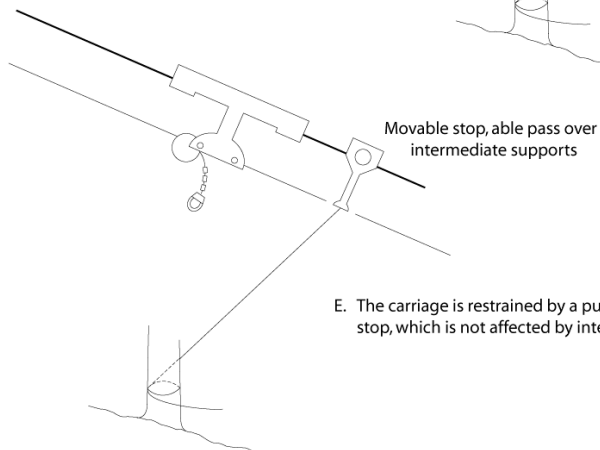

It may be difficult to hold the carriage in the correct position at the landing when unloading. An intermediate support inserted in front of the winch can provide a level stretch of skyline and eliminate any tendency for the carriage to move out under gravity.

### Communications

Clear and unambiguous signals between the winch operator and the chokerman are essential. Safety demands that the winch operator works only on recognised signals. He must obey a "Stop" signal immediately. Any unidentifiable signal should be treated as "Stop".

#### Hand signals

These are satisfactory where visibility is good and over short distances. The winchman has the chokerman in sight when hauling in a load, so reducing the chance of accidents. Fluorescent armlets or bats increase visibility. The standard hand signals (Figure 30) in use in Britain should always be used.

**Figure 30** Hand signals for cableway operators

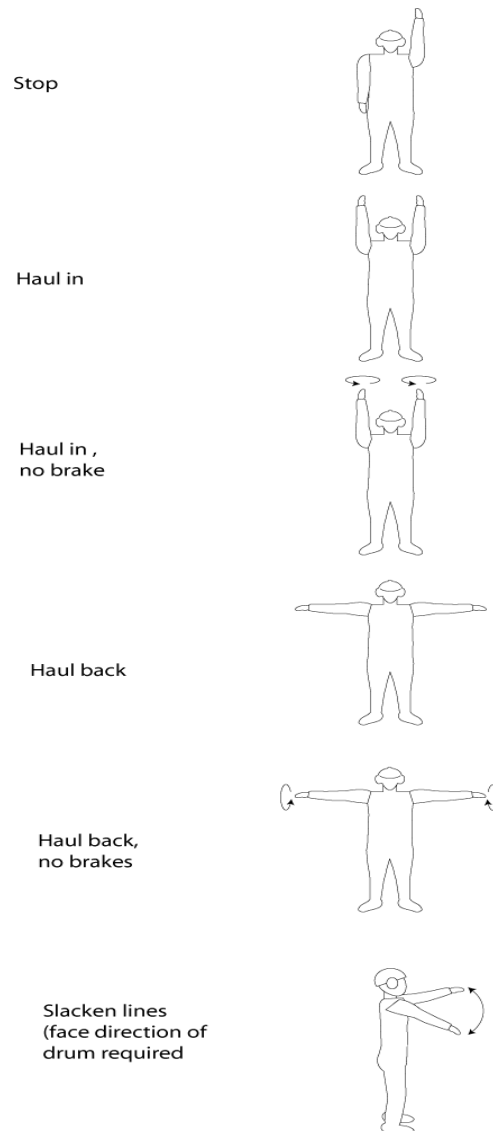

## Radio

This has proved to be the best signalling and communication method, using modern lightweight equipment to improve safety and efficiency.

Equipment should conform to the standards laid down by the licensing department of the Home Office. A mobile transmitter/receiver is used at the winch, with a high mounted magnetic aerial on the cableway tower. The operator must have an effective ear-piece or extension loudspeaker to enable him to hear the signal above the general level of working noise. The chokerman uses a lightweight hand set with a carrying harness and a strap or other flexible aerial, and preferably a remote control microphone/speaker.

The range of radios depends on topography. With a high-mounted aerial on the cableway, they are reliable up to 800 m. Radio communication is of particular value during set-up, saving a lot of time.

Radio equipment must be protected from shock and vibration, damp, wetness frost and excessive heat. Sets not in use should be kept correctly charged, and aerials protected from damage.

Many of the safety clothing and equipment manufacturers now produce safety helmets that can be fitted with radio communication. Voice activated radios have been designed to enable easier communication which should reduce mistakes and accidents.

Radio discipline is vital because a number of cableways may share the same frequency and careless signalling is dangerous.

- Use only the recommended operating signals when extracting. These are listed below.
- All signals must be prefixed with the correct call sign. This is mandatory under government regulations. Each set is allotted a different identification. **This is particularly important where other machinery controlled by radio command is working in the same area.**
- After pressing the transmission switch, wait two seconds before speaking. This is essential, otherwise the call sign or first part of the message may not be transmitted.
- An emergency 'Stop' signal is the only one not requiring a call sign. All winch operators must stop immediately any stop signal is heard.
- Any unidentified signal must be treated as 'Stop'. It may be only static or accidental transmission, but it might be someone trying to say stop.
- Whoever makes an emergency stop signal must identify themselves immediately, so that any other extraction crews receiving 'cross transmission' call can continue.
- Never transmit if anyone else can be heard transmitting. Wait until they have finished before calling the controlling station.
- Confirm any signal not acted upon immediately. There may be an unavoidable delay because of stacking or some other work. Confirm the signal before operating the winch.
- Use the words "haul-in" or "haul-back" only in movement signals as far as possible, avoiding their use in any other context i.e. when referring to brake, drum, clutch etc.
- Talk briefly and keep conversation to a minimum.
- Never converse with other operators.

- Operating signals:
  - Stop
  - Haul-in
  - Haul-in no brake
  - Haul-back no brakes
  - Brake off (haul-in brake only)
  - Both brakes off (when slack required in haul-back line)
  - In the rack
  - Raise skyline
  - Lower skyline.

### Mobile Telephones

The use of mobile telephones has increased. This method is commonly used as an emergency back up for the team to communicate in the event of 'radio' communication failure and in the event of an emergency to communicate with other personnel who are arriving on site.

### **Take Down Procedures**

This is largely the reverse of set-up.

- Haul-in carriage to roadside.
- Slacken off skyline, if used.
- Remove haul-in line and haul-back line from carriage; take carriage off skyline.
- If work is completed in this area, wind in the haul-back line and skyline if used.
- If the outfit is to be set up in the next rack, leave the skyline in the completed rack and wind in the haul-back line only as far as the tail block.
- Take down tail spar tree rigging and move gear to the next rack.
- Take down any supports and move gear to the next rack.
- Take down tractor tower guys and move winch and gear to the next rack.
- Chokerman leaves haul-back line in the extracted rack (if rope capacity is sufficient) and takes haul-back line through block on tail spar tree of the next rack and then to the winch. In thinnings he can use the method illustrated in Figure 24 a. If a skyline is used and it is long enough, this can be taken through a reeving block on the haul-back line which hauls the skyline out of the old rack and into position in the new rack. This saves having to rewind the skyline onto its storage drum at each rack change.
- Over long distances and/or steep uphill climbs, the haul-back line may be too heavy for the chokerman to pull to roadside. A straw-line should be used instead to take the haul-back line to the mouth of the new rack. This can be sent out to the chokerman at the tail spar when extraction is completed. In extreme conditions and where the cableway is equipped with a suitable straw-line drum drive, a back-pack drum of very fine rigging line can be used. The chokerman walks out from the winch to the tail spar tree feeding the line through the pulley blocks and tail spar block. The chokerman returns to the winch where the line is used to take out a light wire straw-line which in turn is used to take out the heavier cables.

The above sequence can be modified on final fellings to take account of artificial supports. It may be possible to move the winch fan-wise, using the same tail spar tree, to make the best use of stacking space. The tail spar tree anchor rope alignment would need to be checked and reset as required. The ropes can often be lifted across to the next extraction line without re-winding.

A rewind is required when ropes become crossed or loose when stored on the winch drum. Haul-in and haul rewinds are shown in Figure 31.

**Figure 31** Rewinding ropes

a Attaching haul-in rope to tower for haul-in rewind

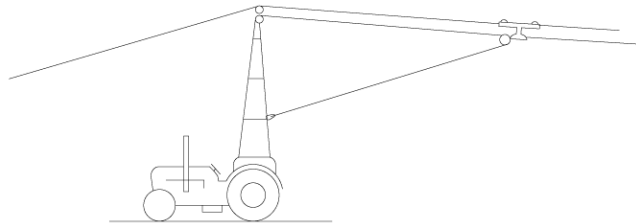

b Rope arrangement for haul-in rewind

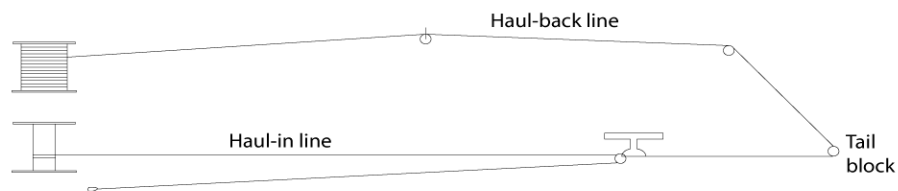

c Arrangement of ropes and blocks for haul-back and rewind

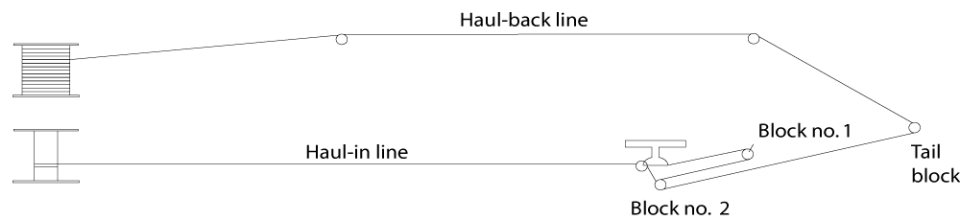

## SAFETY

Risk assessments need to be carried out as described in, The Management of Health and Safety at Work Regulations, 1994 (Health and Safety at Work Act 1974). Regulation Number 3 requires:

*“employers and self employed people to make a suitable and sufficient assessment of risks to employee and any others, such as contractors and members of the public, who may be affected by their undertaking” (organisation business or activity)”.*

Guidance on safety in cableway operations is covered by the following Arboriculture and Forestry Advisory Group (AFAG) safety guides:

AFAG 504	Extraction by cable crane
AFAG 502	Extraction by skidder
AFAG 501	Tractor units in tree work
AFAG 401	Tree climbing operations
AFAG402	Aerial tree rescue
AFAG 804	Electricity at work: Forestry and arboriculture
AFAG 805	Training and certification.

Leaflet AS 24 *Power take-off and power take-off shaft*, produced by the Health and Safety Executive in their Agricultural Safety series, is also relevant.

All cableway operators should have these leaflets and know their contents.

Operators must have the following:

- Safety helmet to EN 397: 1995 specification.
- Ear defenders when operating the winch.
- Heavy duty gloves.
- Safety boots with good grip.
- Non-snag outer clothing.
- First aid kit to SI 1981 no. 917.

The working techniques described in this publication conform to the guidance in these leaflets. It is important that the machine and system are equipped with ropes and components in a serviceable condition, that meet the manufacturer’s recommended specification. The weight of the load must not exceed the manufacturer’s recommended safe working load, which must be clearly stated on the machine.

- The public and traffic must be excluded from the area of work. Work must stop if any person is seen within the exclusion zone of the system.
- Under the new Roads and Street Works Act, 1991 any operation on or near a public highway should give adequate information with regards to signing, lighting and guarding of works.
- Ensure that all permanent and temporary traffic signs must conform to BS 5783 under The Traffic Sign Regulations and General Directions 1994.
- Advice can be found in Health and Safety Memorandum 32 (HSM 32) *Forest Signs – Forest Operations* which details current FC policy.
- Timber should be stacked and maintained in a stable condition. Avoid stacking on top of steep roadside banks. Manually handled timber should not be stacked higher than 1 m. Otherwise, so far as it is reasonably practicable, stack heights should not exceed 2 m.



- Take special care in areas frequented by the public. Stacks must be safe, and where appropriate the standard hazard sign should be displayed and/or the site enclosed with standard hazard warning tape (SI 1980 No. 1471).
- A safe working zone must be maintained between the cableway system and any overhead power lines. It must not cross the route of overhead power cables.
- Consult the electricity company and agree the safe working distance between the type of cableway system being used and the overhead power lines.
- Do not transport a cableway system with the tower raised
- Stop work and move well clear during a thunderstorm due to the risk of lightning strike.
- Processors and other machines should not work within 10 m of the system while ropes are in motion.

### **Safe tree climbing**

Climbing spar and support trees needs care and adequate equipment. Operators should be trained and certificated to carry out the task. Guidance on Tree Climbing Operation and Aerial tree rescue is given in AFAG guides 401 and 402.

AFAG 401 *Tree Climbing Operations* covers information on:

- General information on the operation
- Personal protective equipment (PPE)
- Working position
- Fall arrest systems
- Climbing ropes
- Karabiners
- Using ladders
- Using climbing irons
- Preparing to climb
- Anchor points
- Ascent
- Movement within the tree
- Descent
- Working with tools
- Ground work – What ground staff must do.

AFAG 40 *Aerial Tree Rescue* covers items such as:

- General information on the task
- Rescue equipment
- Helping the casualty
- Climbing to rescue the casualty
- Rescue.

### **REFERENCES**

Biggs, D. (1973). R & D Paper 94 *Cableway design studies*. Forestry Commission, Edinburgh.

Forestry Commission (1994). Technical Development Branch Technical Note 8/94 *Cableway rope discard criteria*.

Samset, I. (1985). *Winch and cable systems*. Dr. W Junk Publishers, Dordrecht, Netherlands.